



CARTRIDGES & MECHANICAL SEALS

Index - Cartridges

Lidering Safe Industry 4

Company	4
Sectors	6
Characteristics	8
Advantages	10

Simple Cartridge 12

LSC10	12
LSC10B-FQ	14
LSC25	16
LSC38-FQ	18
LSC40-F	20
LSC40-F ANSI	22
LSC50-F	24
LSC85	26
LSC211A-FD	28
LSC90	30

Double Cartridge 31

LDC21	32
LDC38	34
LDC39-D	36
LDC40	38
LDC40-ANSI	40
LDC90	42

Agitators and Reactors 43

LMS26	44
LMS27	46
LMS28	48
LSC80	50
LDC80	52
LDC80 FLANGE accessories	54

Auxiliary Products 55

LCY	56
LHP	56
LST8	57
LST9	57
LQT	58
Kitting	58

Production center, Quality control, checking and testing 59

Compatibility Chart 60

Chart	60
-------	----

API Plans 62

API Plans	64
Summary	74

Speciales Design 76

Designs	76
---------	----

General Information 78

Materials Codes	78
-----------------	----

Identification Chart 81

Seals Identification guide	81
Cartridge Identification guide	82

Naming Codes 83

Naming Codes	83
--------------	----

Index - Mechanical Seals

Sectors	86	Auxiliary Products	135
Multispring Seals	90	LCY	135
LMS10D	90	LHP	135
LMS11	91	LQT	136
LMS13	92	LS	136
LMS14	93	LST8-LST9	137
LMS15D	94	Stationary Parts	138
LMS20/ LMS20T	95	Special Designs	141
LMS20B/ LMS20BT	96	RMS Seals	142
LMS22	97	Production Center - Quality Control	149
LMS26	98	Certificates	150
LMS27	99	General Information	151
LMS28	100	Chemical Resistance Chart	163
LMS29	101	Compatibility Chart	166
Wave Spring Seals	102	Related Products	167
LWS10	102	Identification Guide Mechanical Seals	169
LWS10B	103	Identification Guide Cartridges	170
LWS12	104	Naming Codes	171
LWS30 / LWS30A	105		
LWS31	106		
LWS70 / LWS71	107		
Axial Spring Seals: Conical	108		
FH / FHC	108		
FN / LS15 and FN.NU / LS15DIN	109		
LS18 / LS19	110		
LS18B	111		
LS60IL / LS60IN	112		
RN / LS60 and RN.NU / LS60DIN	113		
RNB / LS60B and RN.NB / LS60BDIN	114		
Axial Spring Seals: Cylindrical	115		
LS40A	115		
LS40C	116		
Bellows Seals	117		
LMB84	117		
LMB85	118		
LMB86	119		
LRB00	120		
LRB00U and LRB00L	121		
LRB01-LRB01S- LRB04 -LRB04A and LRB06	122		
LRB02	124		
LRB03- LRB03A- LRB03B	125		
LRB05	127		
LRB17-LRB17A- LRB17E- LRB17KU- LRB17NU	128		
LRB25-R- LRB25KU-R and LRB25NU-R	130		
AR / LRB31	131		
LRB50	132		
LTB16	133		
PNL	134		



We are close to you...

As time goes by, we feel extremely satisfied and proud to be able to contribute to and form part of a responsible, safe industry which is striving to build a better world and a safer future. We are convinced we can offer you a solution that will meet your expectations.

Who we are

History:

Lidering was established in 1975 and specialises in designing, manufacturing, repairing and selling mechanical seals. We provide effective solutions worldwide.

Estrategy:

Our aim is to be recognised in the market for our **accessibility** and **adaptability** to the needs of our customers and the **availability** and **reliability** of our products, solutions and services.

Vision:

We aim to be experts in mechanical seals and associated products for industry.

Accessibility

Contact us using traditional methods or new communication technologies. We are always ready to provide you with the most suitable response.

Availability

Our wide range and efficient processes make it possible to deliver the requested product when it is required.

Adaptability

We provide our customers with advice and guidance. Our design and manufacturing capacity means we are able to customise products and services to their needs.

Reliability

Our customers see us as a trusted partner because we always meet our commitments.

Our values:

The personality of a business is created by the attitude of each member.

Lidering team is a passionate, demanding, responsible and dynamic company. Our goal is to efficiently provide a response to your needs.

Sectors:

We contribute to the success of strategic sectors.

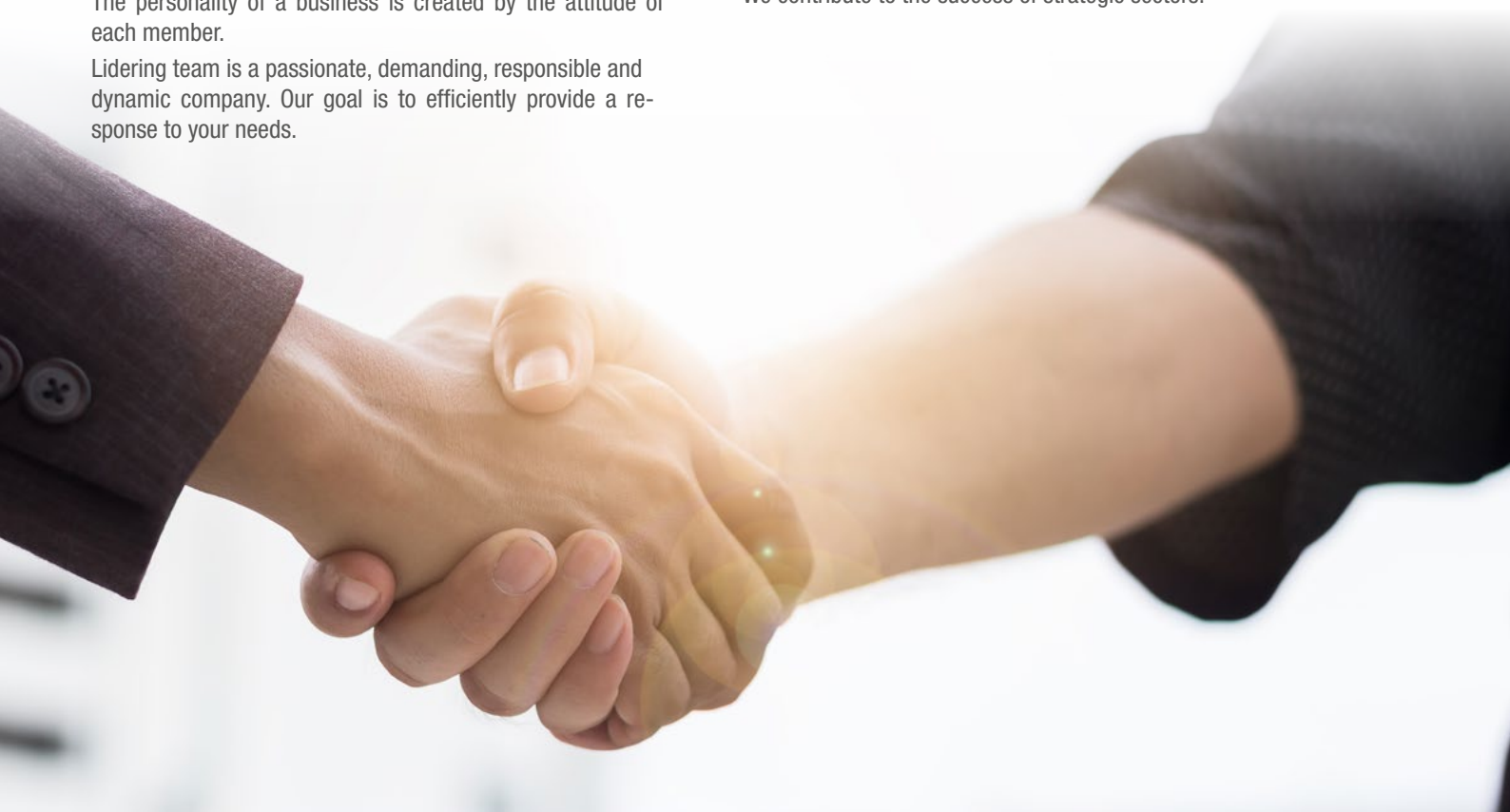

We believe in :

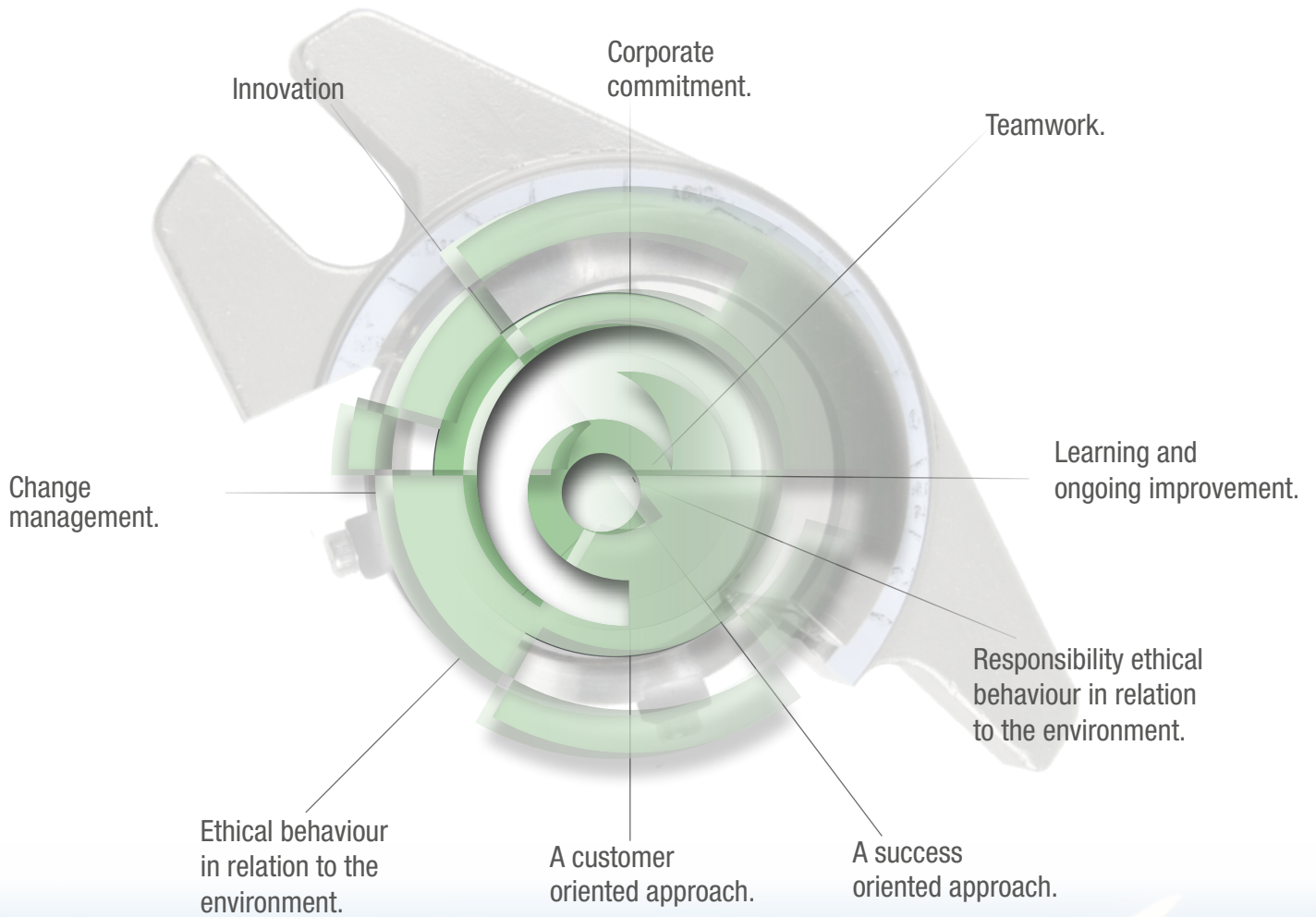

We are part of the businesses and sectors that make our lives safer and simpler.

Our products help protect and take care of the environment.

Sectors



Today, many demanding industrial sectors need sealing systems that guarantee safety for both people and facilities. It is very important to offer quality products that are resistant to extreme conditions such as high pressures and temperatures and that also guarantee impeccable sealing.

This safety is ensured by using single and double cartridge seals for sealing corrosive and/or abrasive fluids containing heavy solids or sticky fluids with scant lubrication. The correct selection of the cartridge seal design and its materials, the use of flush, quench, ring and pumping connections, among others, and their auxiliary elements such as tanks and cyclones considerably extend the useful life of the cartridge seals.





It is just as important to use a product that is technically suitable for the application as it is to be able to install it easily and safely. With this objective in mind, the cartridge seals shown in this catalogue have been designed to reduce all possibilities of error to a minimum during the installation process and also prevent damage to other pump components.

Relevant Characteristics

Some of their most important features are:

- The use of solid contact surfaces to prevent possible deformations, with the ensuing loss of flatness.

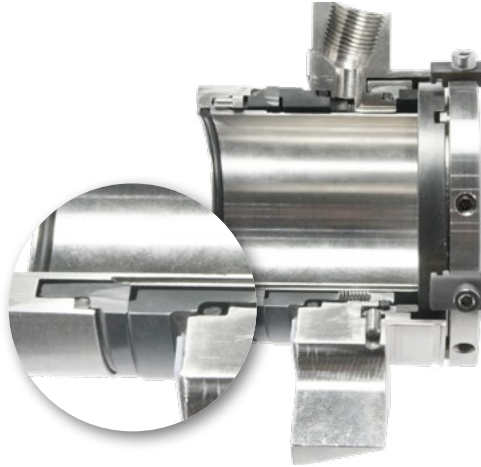

- The O-ring that seals the shaft is static. It avoids the fretting effect on the shaft and its subsequent repair.

- Contact surfaces with an anti-rotation pin to prevent them from sticking together (sticky fluids, dry start-ups) and turning in their housings.



• The springs for compressing the contact surfaces are isolated from the product, which prevents them from becoming blocked by products containing particles, pastes, etc. They are made of Hastelloy material and have great chemical resistance and mechanical properties superior to those of stainless steel.



• A flat self-adhesive seal that facilitates the positioning and prevents failures during the installation process.



• Contact surfaces made of sintered silicon carbide (Q1), suitable for working with the most aggressive products in the chemical industry.



• Self-centering clips that assure the cartridge is installed correctly.



Advantages

Benefits of cartridge seals as opposed to other more traditional sealing systems, such as packing:



- All of our cartridge seals are factory-tested to guarantee they function correctly.



- They are easy and quick to install.



- Their sealing system does not damage the shaft surface.



- They provide complete sealing with no drips.



- They are cleaner in environmental terms.



- They require no maintenance; unlike braided packing, the cartridge requires no re-tightening.

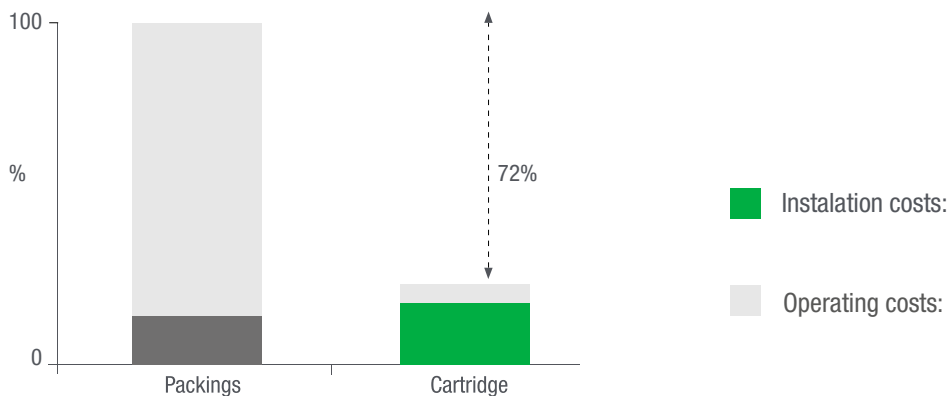

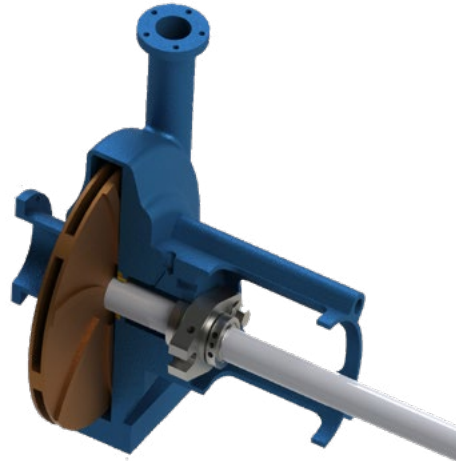
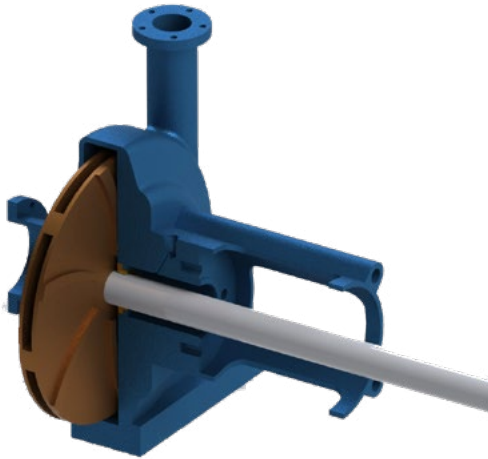
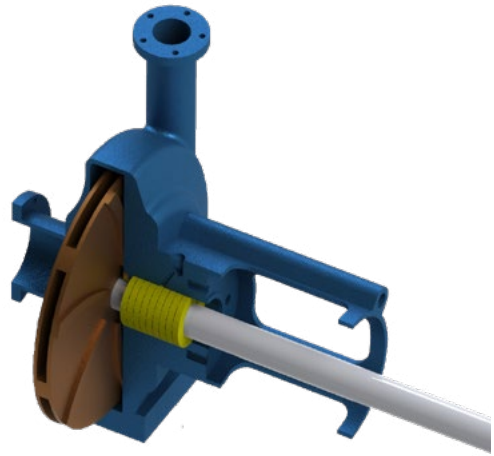
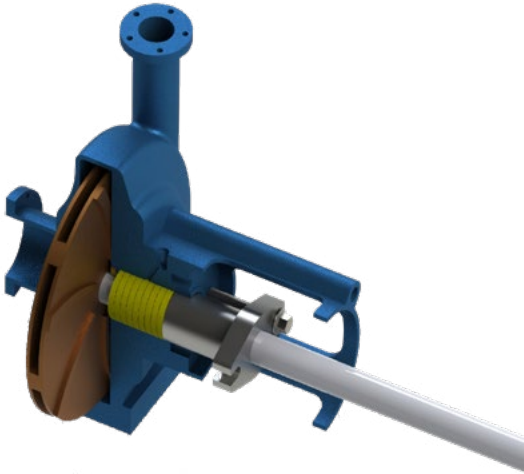

• They reduce the pump power consumption.



• There are no product leaks.

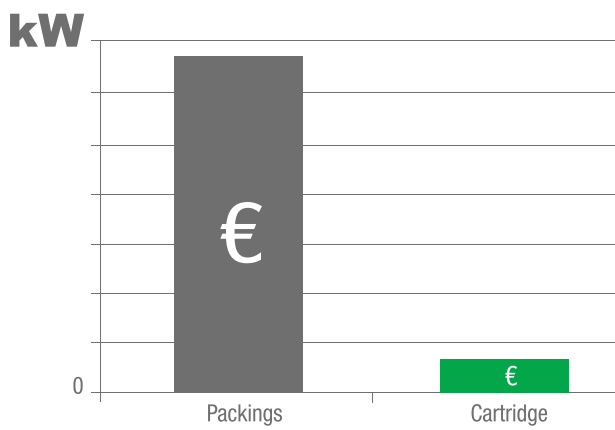



CHARACTERISTICS:

- Unbalanced
- Not dependent on the rotation direction.
- Wave spring

OPERATING LIMITS:

$$d_1 = 24 \div 95 \text{ mm} \quad p = 10 \text{ kg/cm}^2$$

$$v = 20 \text{ m/s} \quad t = -15 \div +200^\circ\text{C} (*)$$

(*) The temperature resistance depends on the material of the secondary seals used.

The operating limits are defined by the PV factor which is determined for the sealing system characteristics and those of the application.

DESCRIPTION:

Single cartridge in which due to its geometry, the rotating part has a wave spring to prevent it from blocking when in contact with viscous fluids or fibres.

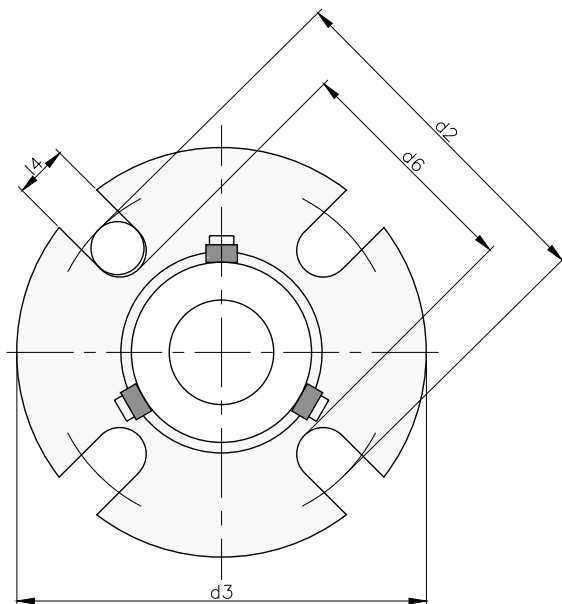

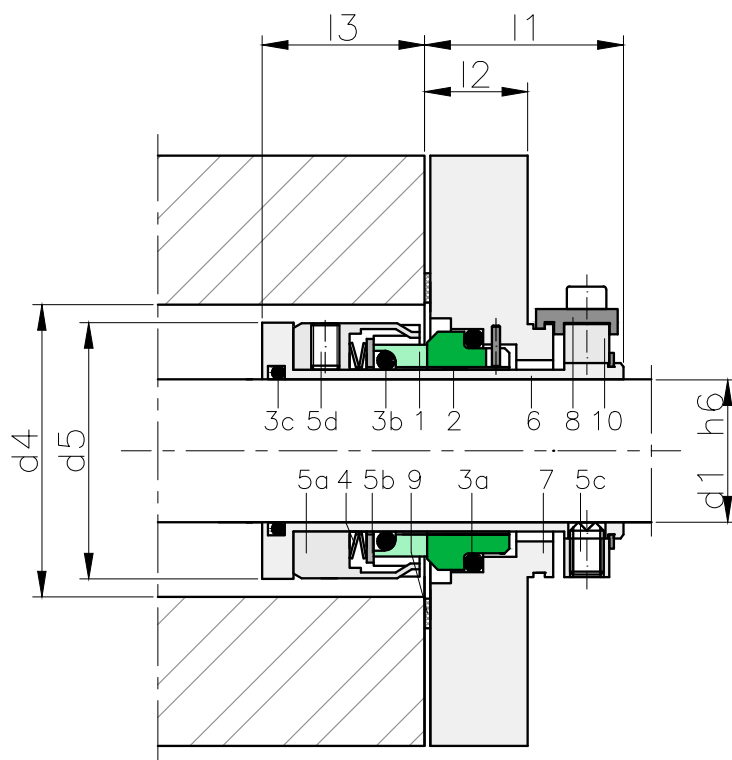

COMPONENTS:

- 1 Rotating contact surface
- 2 Stationary contact surface
- 3 O-rings
- 4 Metal bellows
- 5a Metal frame
- 5b Ring
- 5c Set screws
- 5d Set screws
- 6 Sleeve
- 7 Flange
- 8 Setting clips
- 9 Flat gasket
- 10 Drive ring

DIMENSIONS CHART

Dimensions in mm

Shaft											
mm	d ₂ min.	d ₂ max.	d ₃	d ₄ min.	d ₄ max.	d ₅	d ₆	l ₁	l ₂	l ₃	l ₄
24	72	93	105	44	52	43	60	32	21	41	12
25	72	93	105	44	52	43	60	32	21	41	12
28	72	93	105	49	52	47	60	32	21	41	12
30	76	98	110	49	56	48	64	32	21	41	12
32	77	98	110	51	57	50	65	32	21	41	12
33	81.5	103	115	57	61.5	55	69.5	32	21	43,5	12
35	81.5	103	115	57	61.5	55	69.5	32	21	43,5	12
38	86	108	120	62	66	60	74	32	21	42	12
40	88	108	120	62	68	60	76	32	21	42	12
43	90.5	123	135	67	70.5	65	78.5	32	21	42	12
45	93	123	135	67	73	65	81	32	21	42	12
48	98	123	135	74	78	70	86	32	21	45,5	12
50	100	123	135	74	78	70	88	32	21	45,5	12
55	111	134	150	82	85	81	95	32	21	50,5	16
60	121	130	150	87	91	86	101	32	21	50,5	20
65	128.5	140	160	93	98.5	91	108.5	32	21	57	20
70	138	155	175	100	108	99	118	32	21	57	20
75	148	170	190	105	118	104	128	32	21	57	20
80	154	170	190	111	124	109	134	32	21	57	20
85	158	170	190	116	128	114	138	32	21	62	20
90	165	195	215	121	135	119	145	32	21	63	20
95	168	195	215	126	138	124	148	32	21	63	20

Dimensions subject to changes or modifications.



CHARACTERISTICS:

- Balanced.
- Multispring.
- Not dependent on the rotation direction.
- Flush and drain connections.
- API 682 / ISO 21049.
- Categories 2 and 3, Type A, Arrangement 1.

OPERATION LIMITS:

$$d_1 = 19,05 \div 110 \text{ mm} \quad p = 40 \text{ kg/cm}^2$$

$$v = 23 \text{ m/s} \quad t = -40 \div +220^\circ\text{C} (*)$$

(*) The temperature resistance depends on the material of the secondary seals used.

The operating limits are defined by the PV factor which is determined for the sealing system characteristics and those of the application.

DESCRIPTION:

Simple cartridge with connections for washing between the friction faces and the Quench system with unpressurized fluid for cooling. For applications where high pressure is required.

The special characteristics of the cartridge provide great robustness and reliability.

Its design allows axial movement of up to ± 2.0 mm, depending on the diameter and mounting.

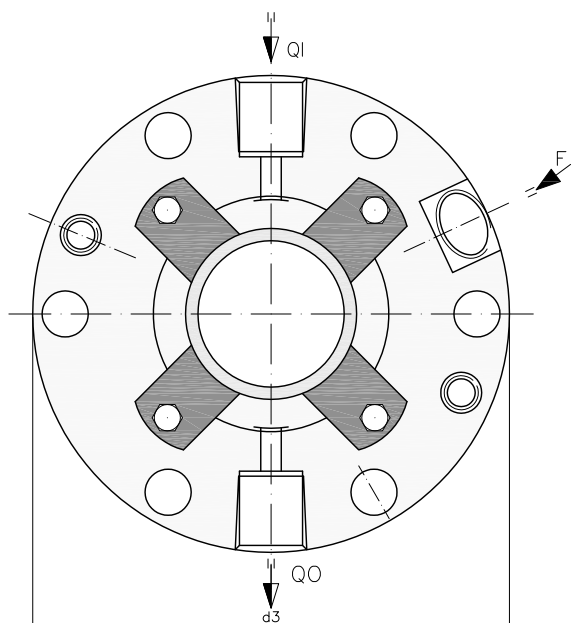

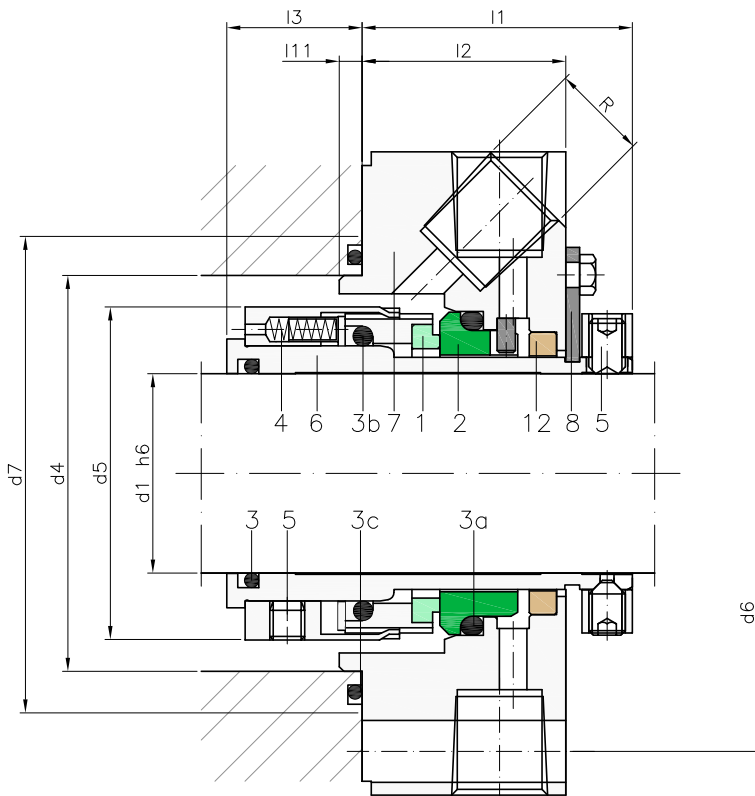

COMPONENTS:

- 1 Rotating contact surface
- 2 Stationary contact surface
- 3 O-ring
- 4 Springs
- 5 Drive ring
- 6 Sleeve
- 7 Flange
- 8 Setting clips
- 12 PTFE ring for quench.

DIMENSIONS CHART

Dimensions in mm

Shaft										
mm	d ₃	d ₄	d ₅	d ₆	d ₇	l ₁	l ₂	l ₃	l ₁₁	
20	138,0	70,0	50,0	105,0	85,0	94,0	76,0	1,0	6,0	
30	148,0	80,0	62,0	115,0	95,0	98,0	77,0	2,5	6,0	
40	158,0	90,0	72,0	125,0	105,0	98,5	77,5	7,0	6,0	
50	168,0	100,0	86,0	140,0	115,0	99,5	78,5	12,0	6,0	
60	188,0	120,0	99,0	160,0	135,0	102,0	81,0	18,5	6,0	
70	198,0	130,0	109,0	170,0	145,0	106,0	81,0	18,0	6,0	
80	208,0	140,0	119,0	180,0	155,0	106,0	81,0	23,0	6,0	
90	238,0	160,0	129,0	205,0	175,0	106,0	81,0	23,0	6,0	
100	248,0	170,0	153,0	215,0	185,0	109,0	81,0	24,0	6,0	
110	258,0	180,0	168,0	225,0	195,0	109,0	81,0	24,0	6,0	

Dimensions in inches

Shaft										
(")	mm	d ₃	d ₄	d ₅	d ₆	d ₇	l ₁	l ₂	l ₃	l ₁₁
0,750	19,05	138,0	70,0	50,0	105,0	85,0	94,0	76,0	1,0	6,0
1,125	28,575	148,0	80,0	62,0	115,0	95,0	98,0	77,0	2,5	6,0
1,500	38,10	158,0	90,0	72,0	125,0	105,0	98,5	77,5	7,0	6,0
2,000	50,80	168,0	100,0	86,0	140,0	115,0	99,5	78,5	12,0	6,0
2,250	57,15	188,0	120,0	99,0	160,0	135,0	102,0	81,0	18,5	6,0
2,750	69,85	198,0	130,0	109,0	170,0	145,0	106,0	81,0	18,0	6,0
3,125	79,38	208,0	140,0	119,0	180,0	155,0	106,0	81,0	23,0	6,0
3,500	88,90	238,0	160,0	129,0	205,0	175,0	106,0	81,0	23,0	6,0
3,750	95,25	248,0	170,0	153,0	215,0	185,0	109,0	81,0	24,0	6,0
4,250	107,95	258,0	180,0	168,0	225,0	195,0	109,0	81,0	24,0	6,0

Dimensions subject to changes or modifications.



CHARACTERISTICS:

- Balanced.
- Not dependent on the rotation direction.
- Single cylindrical spring.

OPERATING LIMITS:

$$d_1 = 24 \div 95 \text{ mm} \quad p = 20 \text{ kg/cm}^2$$

$$v = 15 \text{ m/s} \quad t = -15 \div +200^\circ\text{C} (*)$$

(*) The temperature resistance depends on the material of the secondary seals used.

The operating limits are defined by the PV factor which is determined for the sealing system characteristics and those of the application.

DESCRIPTION:

Single cartridge in which the rotating part has metal tabs that reduce fatigue and tension in the rubber bellows when in the working position.

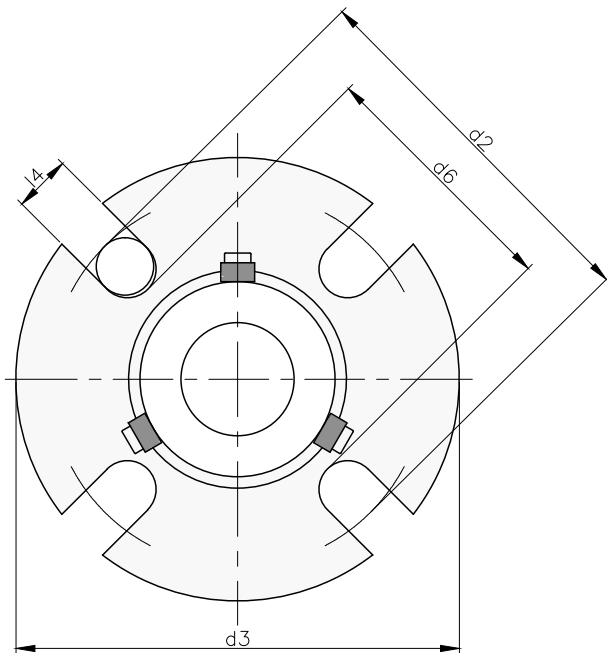

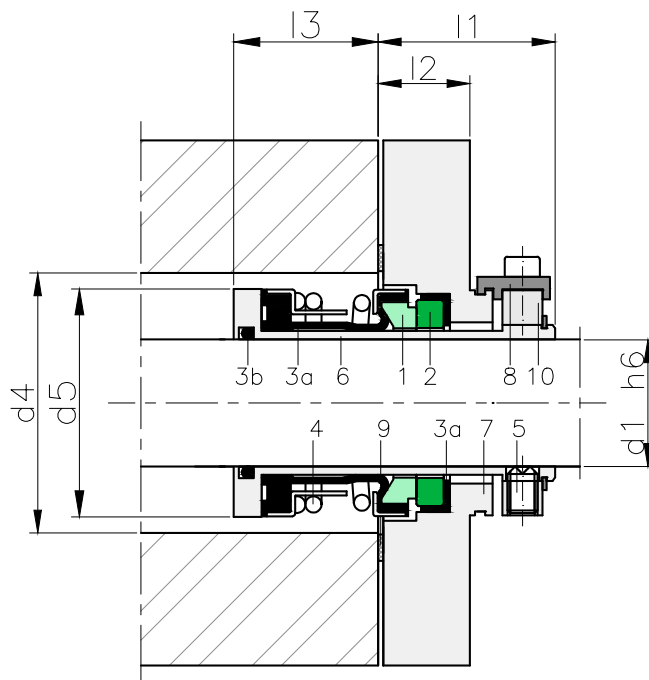

COMPONENTS:

- 1 Rotating contact surface
- 2 Stationary contact surface
- 3a Rubber bellows
- 3b O-ring
- 4 Spring
- 5 Set screws
- 6 Sleeve
- 7 Flange
- 8 Setting clips
- 9 Flat gasket
- 10 Drive ring

DIMENSIONS CHART

Dimensions in mm

Shaft											
mm	d ₂ min.	d ₂ max.	d ₃	d ₄ min.	d ₄ max.	d ₅	d ₆	l ₁	l ₂	l ₃	l ₄
24	72	93	105	44	52	43	60	32	21	41	12
25	72	93	105	44	52	43	60	32	21	41	12
28	72	93	105	49	52	47	60	32	21	41	12
30	76	98	110	49	56	48	64	32	21	41	12
32	77	98	110	51	57	50	65	32	21	41	12
33	81.5	103	115	57	61.5	55	69.5	32	21	43,5	12
35	81.5	103	115	57	61.5	55	69.5	32	21	43,5	12
38	86	108	120	62	66	60	74	32	21	42	12
40	88	108	120	62	68	60	76	32	21	42	12
43	90.5	123	135	67	70.5	65	78.5	32	21	42	12
45	93	123	135	67	73	65	81	32	21	42	12
48	98	123	135	74	78	70	86	32	21	45,5	12
50	100	123	135	74	78	70	88	32	21	45,5	12
55	111	134	150	82	85	81	95	32	21	50,5	16
60	121	130	150	87	91	86	101	32	21	50,5	20
65	128.5	140	160	93	98.5	91	108.5	32	21	57	20
70	138	155	175	100	108	99	118	32	21	57	20
75	148	170	190	105	118	104	128	32	21	57	20
80	154	170	190	111	124	109	134	32	21	57	20
85	158	170	190	116	128	114	138	32	21	62	20
90	165	195	215	121	135	119	145	32	21	63	20
95	168	195	215	126	138	124	148	32	21	63	20

Dimensions subject to changes or modifications.



CHARACTERISTICS:

- Balanced.
- Welded Metal bellows.
- Not dependent on the rotation direction.
- Flushing and quenching connections.

OPERATING LIMITS:

$$d_1 = 25 \div 80 \text{ mm} \quad p = 20 \text{ kg/cm}^2$$

$$v = 25 \text{ m/s} \quad t = -15 \div +200^\circ\text{C} (*)$$

(*) The temperature resistance depends on the material of the secondary seals used.

The operating limits are defined by the PV factor which is determined for the sealing system characteristics and those of the application.

DESCRIPTION:

A single cartridge seal that permits the injection of external fluids (quenching and flushing) and the recirculation of internal fluids (flushing).

The rotating part of the seal has a self-cleaning metal bellows structure.

Suitable for applications with extremely viscous, sticky fluids laden with particles that run a risk of freezing, solidification or sedimentation.

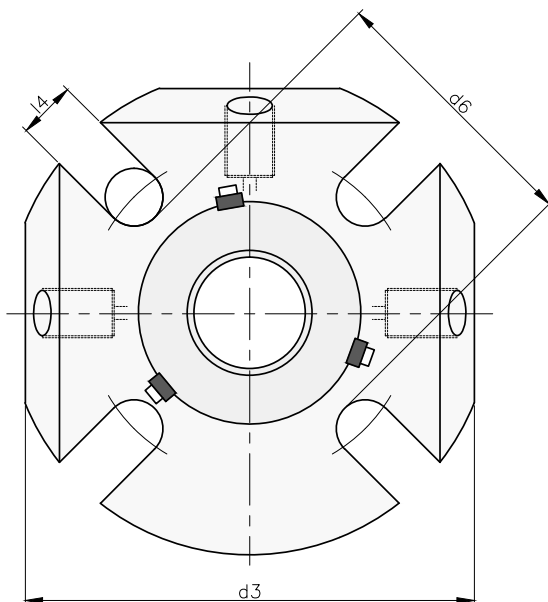

CONNECTIONS (R):

From 25 mm to 65 mm: 1/4" NPT.

From 70 mm to 80 mm: 3/8" NPT.

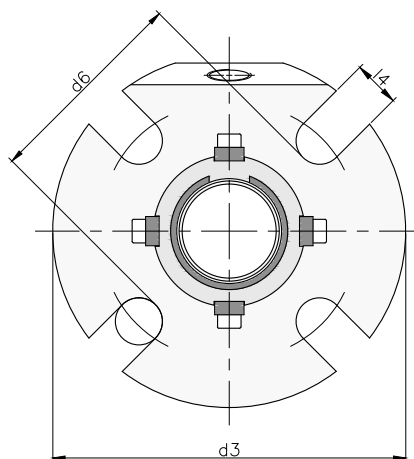

CHARACTERISTICS:

- Balanced.
- Multispring.
- Not dependent on the rotation direction.
- Flushing connections.

OPERATION LIMITS:

$d_1 = 25 \div 100 \text{ mm}$ $p = 25 \text{ kg/cm}^2$

$v = 16 \text{ m/s}$ $t = -15 \div +200^\circ\text{C} (*)$

(*) The temperature resistance depends on the material of the secondary seals used.

The operating limits are defined by the PV factor which is determined for the sealing system characteristics and those of the application.

DESCRIPTION:

A single cartridge with connections for flushing the seal contact faces. The springs are protected from the product to prevent blocking in applications with particle-laden fluids. The standard flange has a connection for flushing to clean and cool the faces (LSC40-F)

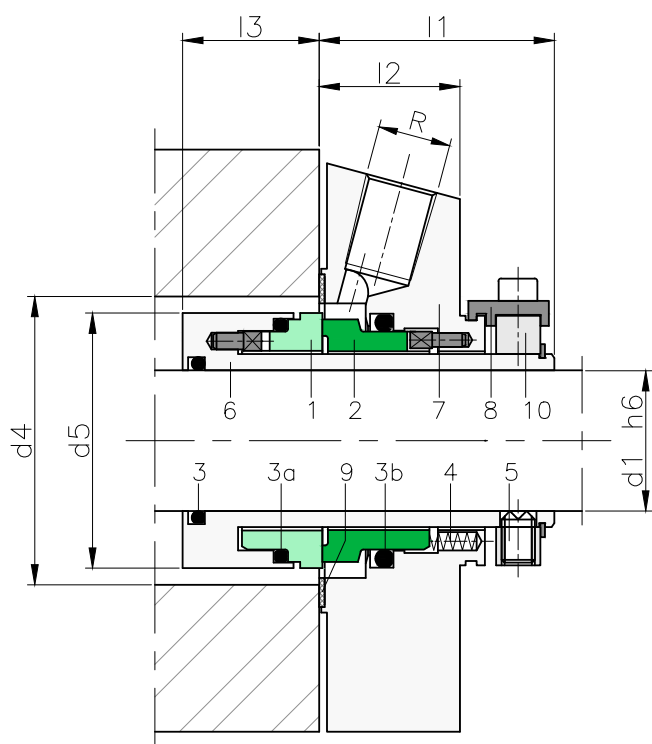

LSC40-F

COMPONENTS:

- | | |
|------------------------------|-------------------------------------------------------------|
| 1 Rotating contact surface | 8 Setting clips |
| 2 Stationary contact surface | 9 Flat gasket |
| 3 O-rings | 10 Drive ring |
| 4 Springs | 11 Lip seal quench |
| 5 Set screws | 12 Throttle ring PTFE carbon
-graphite reinforced quench |
| 6 Sleeve | |
| 7 Flange | |

CONNECTIONS (R):

From 25 mm to 35 mm: 1/4" NPT.
From 38 mm to 100 mm: 3/8" NPT.

DIMENSIONS CHART

Dimensions in inches

Shaft		d ₃	d ₄ min.	d ₄ máx.	d ₅	d ₆	l ₁	l ₂	l ₃	l ₄	l ₁₂	l ₁₃	l ₁₄	l ₁₅	l ₁₆	l ₁₇
(")	mm															
1,000	25,4	105,0	44,5	50,8	43,0	62,0	42,4	25,4	24,6	13,2	35,0	32,0	17,5	79,5	53,4	26,1
1,125	28,6	105,0	47,6	52,1	46,0	62,0	42,4	25,4	24,6	13,2	35,0	32,0	17,5	79,5	53,4	26,1
1,250	31,8	110,0	50,8	57,2	49,8	67,1	42,4	25,4	24,6	13,2	35,0	32,0	17,5	79,5	53,4	26,1
1,375	34,9	113,0	54,0	61,5	53,0	69,9	42,4	25,4	24,6	13,2	35,0	32,0	17,5	79,5	53,4	26,1
1,500	38,1	123,0	57,2	66,7	55,9	74,9	42,4	25,4	24,6	13,2	35,0	32,0	17,5	79,5	53,4	26,1
1,625	41,3	123,0	60,3	68,6	59,4	77,0	42,4	25,4	24,6	15,2	35,0	32,0	17,5	79,5	53,4	26,1
1,750	44,5	138,0	63,5	71,4	62,5	81,0	42,4	25,4	24,6	15,2	35,0	32,0	17,5	79,5	53,4	26,1
1,875	47,6	138,0	66,7	74,7	65,6	81,0	42,4	25,4	24,6	15,2	35,0	32,0	17,5	79,5	53,4	26,1
2,000	50,8	148,0	69,9	81,0	68,0	87,1	42,4	25,4	24,6	15,2	35,0	32,0	17,5	79,5	53,4	26,1
2,125	53,98	148,0	73,0	87,3	72,0	97,0	42,4	25,4	24,6	18,0	35,0	32,0	17,5	79,5	53,4	26,1
2,250	57,2	157,0	76,2	90,4	75,2	100,1	42,4	25,4	24,6	18,0	35,0	32,0	17,5	79,5	53,4	26,1
2,375	60,3	157,0	79,4	91,2	78,0	102,1	42,4	25,4	24,6	18,0	35,0	32,0	17,5	79,5	53,4	26,1
2,500	63,5	163,0	82,6	96,5	81,6	105,9	42,4	25,4	24,6	18,0	35,0	32,0	17,5	79,5	53,4	26,1
2,625	66,7	163,0	85,7	100,0	84,8	109,0	42,4	25,4	24,6	18,0	35,0	32,0	17,5	79,5	53,4	26,1
2,750	69,9	178,0	95,3	108,0	93,0	118,1	42,4	25,4	24,6	18,0	35,0	37,9	22,0	79,5	53,4	26,1
2,875	73,0	190,0	101,6	118,0	100,0	129,0	57,4	25,4	26,6	18,0	46,1	37,9	22,0	--	--	--
3,000	76,2	190,0	101,6	118,0	100,0	129,0	57,4	25,4	26,6	18,0	46,1	37,9	22,0	98,0	63,9	34,1
3,125	79,4	195,0	104,8	121,0	106,4	135,0	57,4	25,4	26,6	18,0	46,1	37,9	22,0	98,0	63,9	34,1
3,250	82,6	195,0	108,0	124,0	106,4	135,0	57,4	28	26,6	18,0	46,1	37,9	22,0	98,0	63,9	34,1
3,375	85,7	198,0	111,1	128,0	109,5	139,0	57,4	28	26,6	22,0	46,1	37,9	22,0	98,0	63,9	34,1
3,500	88,9	198,0	114,3	131,0	112,7	142,0	57,4	28	26,6	22,0	46,1	37,9	22,0	98,0	63,9	34,1
3,625	92,1	205,0	117,5	135,0	115,9	145,0	57,4	28	26,6	22,0	46,1	37,9	22,0	98,0	63,9	34,1
3,750	95,3	208,0	120,7	138,0	119,1	148,0	57,4	28	26,6	22,0	46,1	37,9	22,0	98,0	63,9	34,1
4,000	101,6	218,0	127,0	144,0	125,4	154,0	57,4	28	26,6	22,0	46,1	37,9	22,0	--	--	--

Dimensions subject to changes or modifications.

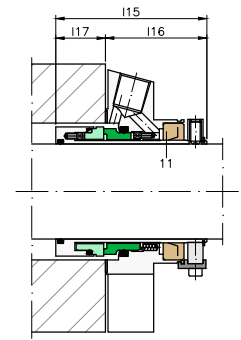

LSC40-FQO

Single cartridge with connections for quench and flush between the faces, with a non-pressurised fluid. The quench fluid sealing is done through an oil seal. For applications using fluids with scant lubrication.

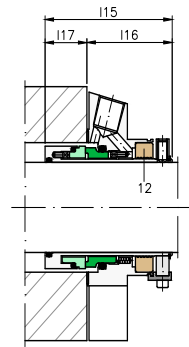

LSC40-FQG

Single cartridge with connections for quench and flush between the faces, with a non-pressurised fluid. The quench fluid sealing is done through a throttle ring PTFE carbon-graphite reinforced.

DIMENSIONS CHART

Dimensions in mm

Shaft		l ₁	l ₂	l ₃	l ₄	l ₁₂	l ₁₃	l ₁₄	l ₁₅	l ₁₆	l ₁₇	d ₃	d ₄ min.	d ₄ máx.	d ₅	d ₆
25	42,4	25,4	24,6	13,2	35,0	32,0	17,5	79,5	53,4	26,1	105	44	51,5	43	62	
28	42,4	25,4	24,6	13,2	35,0	32,0	17,5	79,5	53,4	26,1	105	47	52	46	62	
30	42,4	25,4	24,6	13,2	35,0	32,0	17,5	79,5	53,4	26,1	110	49	56	48	65	
32	42,4	25,4	24,6	13,2	35,0	32,0	17,5	79,5	53,4	26,1	110	51	57	49,8	67	
33	42,4	25,4	24,6	13,2	35,0	32,0	17,5	79,5	53,4	26,1	113	51	57	49,8	67	
35	42,4	25,4	24,6	13,2	35,0	32,0	17,5	79,5	53,4	26,1	123	54	61,5	53	70	
38	42,4	25,4	24,6	14,2	35,0	32,0	17,5	79,5	53,4	26,1	123	57	66	56	75	
40	42,4	25,4	24,6	14,2	35,0	32,0	17,5	79,5	53,4	26,1	123	59	68	58	75	
42	42,4	25,4	24,6	14,2	35,0	32,0	17,5	79,5	53,4	26,1	133	61,5	69,5	60,5	80	
43	42,4	25,4	24,6	14,2	35,0	32,0	17,5	79,5	53,4	26,1	138	61,5	70,5	60,5	80	
45	42,4	25,4	24,6	14,2	35,0	32,0	17,5	79,5	53,4	26,1	138	64	73	62,5	81	
48	42,4	25,4	24,6	14,2	35,0	32,0	17,5	79,5	53,4	26,1	138	67	75	65,6	84	
50	42,4	25,4	24,6	18	35,0	32,0	17,5	79,5	53,4	26,1	148	69	78	68	87	
53	42,4	25,4	24,6	18	35,0	32,0	17,5	79,5	53,4	26,1	148	73	87	72	97	
55	42,4	25,4	24,6	18	35,0	32,0	17,5	79,5	53,4	26,1	148	74	83	73	90	
60	42,4	25,4	24,6	18	35,0	32,0	17,5	79,5	53,4	26,1	157	79	91	78	102	
65	42,4	25,4	24,6	18	35,0	32,0	17,5	79,5	53,4	26,1	163	85,7	98,5	84,8	109	
70	42,4	25,4	24,6	18	35,0	32,0	17,5	79,5	53,4	26,1	178	95	108	93	118	
75	57,4	28	26,6	18	46,1	37,9	22,0	98,0	63,9	34,1	190	101,6	118	100	129	
80	57,4	28	26,6	18	46,1	37,9	22,0	98,0	63,9	34,1	195	108	124	106,4	135	
85	57,4	28	26,6	22	46,1	37,9	22,0	98,0	63,9	34,1	198	111,1	128	109,5	139	
90	57,4	28	26,6	22	46,1	37,9	22,0	98,0	63,9	34,1	205	117,5	135	115,9	145	
95	57,4	28	26,6	22	46,1	37,9	22,0	98,0	63,9	34,1	208	120,7	138	119,1	148	
100	57,4	28	26,6	22	46,1	37,9	22,0	98,0	63,9	34,1	218	127	144	125,4	154	

Dimensions subject to changes or modifications.

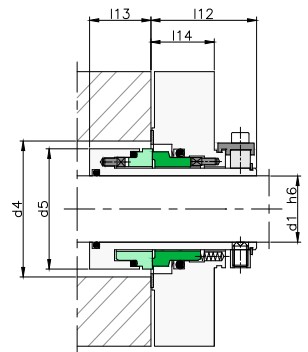

LSC40

Single cartridge with no connections, for closed chamber applications in which no water recirculation is necessary. Applications: Clean fluids

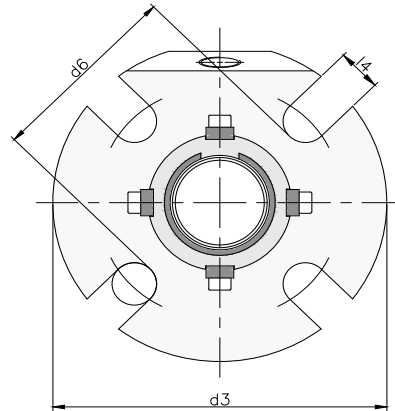

CHARACTERISTICS:

- Balanced.
- Multispring.
- Not dependent on the rotation direction.
- Flushing connections.

OPERATING LIMITS:

$d_i = 25,4 \div 95,3 \text{ mm}$ $p = 25 \text{ kg/cm}^2$

$v = 16 \text{ m/s}$ $t = -15 \div +200^\circ\text{C} (*)$

(*) The temperature resistance depends on the material of the secondary seals used.

The operating limits are defined by the PV factor which is determined for the sealing system characteristics and those of the application.

DESCRIPTION:

A single cartridge with connections for flushing the seal contact faces. The springs are protected from the product to prevent blocking in applications with particle-laden fluids. The standard flange has a connection for flushing to clean and cool the faces.

Recommended for flange pumps ANSI Standard bore and ansi big bore

CONNECTIONS (R):

From 25,4 mm to 34,9 mm: 1/4" NPT.

From 38,1 mm to 95,3 mm: 3/8" NPT.

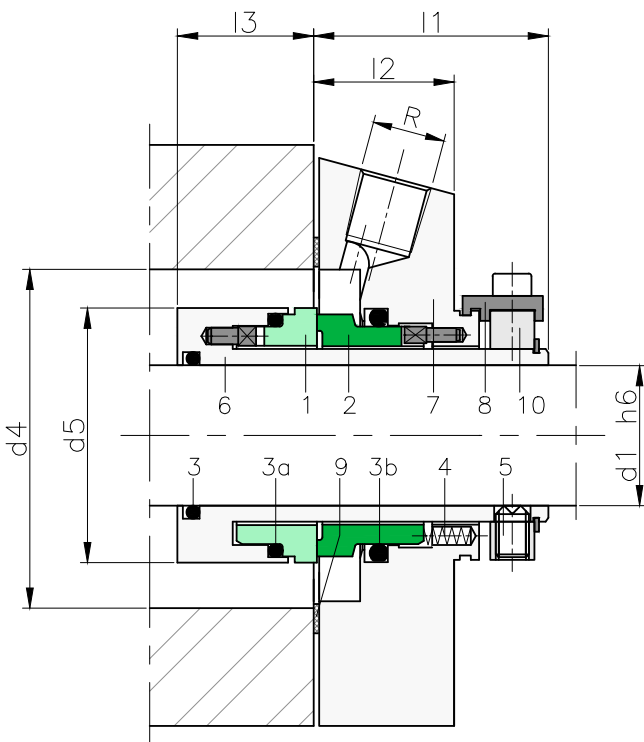

COMPONENTS:

- | | |
|------------------------------|-------------------------------------------------------------|
| 1 Rotating contact surface | 8 Setting clips |
| 2 Stationary contact surface | 9 Flat gasket |
| 3 O-rings | 10 Drive ring |
| 4 Springs | 11 Lip seal quench |
| 5 Set screws | 12 Throttle ring PTFE carbon
-graphite reinforced quench |
| 6 Sleeve | |
| 7 Flange | |

DIMENSIONS CHART ANSI BIG BORE

Dimensions in inches

LSC40-FQ0AB LSC40-FQGAB LSC40-FAB

Shaft													
(")	mm	d ₃	d ₄ min.	d ₄ max.	d ₅	d ₆	l ₁	l ₂	l ₃	l ₄	l ₁₅	l ₁₆	l ₁₇
1,000	25,4	--	--	--	--	--	--	--	--	--	--	--	--
1,125	28,5	114,3	44,5	71	43,5	84,1	42,3	25,4	24,6	11,1	74,6	48,4	26,1
1,250	31,7	--	--	--	--	--	--	--	--	--	--	--	--
1,375	35	130	50,8	81	49,7	90	42,3	25,4	24,6	11,1	74,8	48,7	26,1
1,500	38,1	--	--	--	--	--	--	--	--	--	--	--	--
1,625	41,2	--	--	--	--	--	--	--	--	--	--	--	--
1,750	44,4	165	63,5	103	62,5	116	42,3	25,4	24,6	14,2	76,5	50,3	26,1
1,875	47,6	152	67,5	100	65,6	112	42,3	25,4	24,6	14	78	52,3	25,7
2,000	50,8	160	70	116	68	124	42,3	32	18	14	79,5	53,3	26,1
2,125	54	175	74	115	72	134	42,3	25,4	24,6	18	76,5	50,3	26,1
2,250	57,1	163	78,5	112	75,1	119	48,7	32,4	17,6	18	79,5	53,8	26,1
2,500	63,5	198	83,7	134	81,5	140	48,7	31,7	18,2	18	79,5	53,8	26,1
2,625	66,6	175	80,5	130	84,7	136	48,7	31,7	18,2	18	79,5	53,8	26,1
2,750	69,8	190	95	133	93	140	49,4	32,4	17,6	16	79,5	53,8	26,1
3,000	76,2	209	102	140	100	150	57,8	32,4	26,1	16,5	98	64	34,1
3,250	82,5	--	--	--	--	--	--	--	--	--	--	--	--

Dimensions subject to changes or modifications.

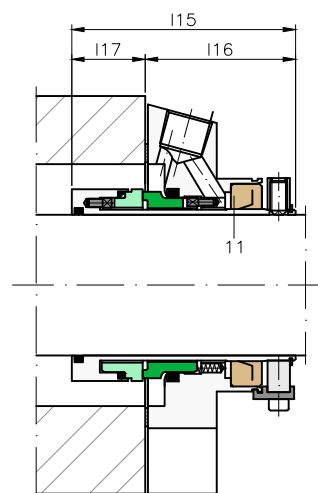

LSC40-FQ0AB : ANSI BIG BORE
LSC40-FQ0AS : ANSI STANDARD BORE

Single cartridge with connections for quench and flush between the faces, with a non-pressurised fluid. The quench fluid sealing is done through a lip seal. For applications using fluids with scant lubrication.

DIMENSIONS CHART ANSI STANDARD BORE

Dimensions in inches

LSC40-FQ0AS LSC40-FQGAS LSC40-FAS

Shaft													
(")	mm	d ₃	d ₄ min	d ₄ max	d ₅	d ₆	l ₁	l ₂	l ₃	l ₄	l ₁₅	l ₁₆	l ₁₇
1,000	25,4	100	44	56	43	70	42,3	25,4	24,6	11	74,6	48,4	26,1
1,125	28,6	105	44,5	67	43,5	62	42,3	25,4	24,6	11,1	74,6	48,4	26,1
1,250	31,8	108	51	61	50	67	42,3	25,4	24,6	11	79,5	53,3	26,1
1,375	34,9	107	50,8	61	49,8	70,1	42,3	25,4	24,6	11,1	74,8	48,7	26,1
1,500	38,1	114	57	69	55,8	75	42,3	25,4	24,6	14	79,5	53,3	26,1
1,625	41,3	125	61,4	71	59,4	77	42,3	25,4	24,6	14	79,5	53,3	26,1
1,750	44,5	130	63,5	75	62,5	82	42,3	25,4	24,6	14,2	76,5	50,3	26,1
1,875	47,6	130	67,5	78	65,6	81	42,3	25,4	24,6	14	78	51,8	26,1
2,000	50,8	139	70	81	68	87,1	42,3	25,4	24,6	16	79,5	53,3	26,1
2,125	54,0	140	74	91	71,9	97	42,3	25,4	24,6	16,5	76,5	50,3	26,1
2,250	57,2	149	77,1	91	75,1	98	42,3	25,4	24,6	16,5	79,5	53,3	26,1
2,375	60,3	157	79,3	91,1	77,9	102,1	42,3	25,4	24,6	18	25,4	25,4	25,4
2,500	63,5	170	83,5	100	81,5	115	42,3	28,5	24,6	18	79,5	53,3	26,1
2,625	66,7	162	86,7	102	84,7	115	42,3	31,7	24,6	16	79,5	53,3	26,1
2,750	69,9	189	95	111	92,9	118	49	32	18	18	79,5	53,3	26,1
3,000	76,2	199	102	120	100	127	57,4	32	26,5	18	98	64	34,1
3,250	82,6	198,8	108,4	125	106,4	135	57,4	32	26,5	18	98	64	34,1
3,750	95,3	208	120,6	138	119,1	148	57,4	25,4	26,5	22	25,4	25,4	25,4

Dimensions subject to changes or modifications.

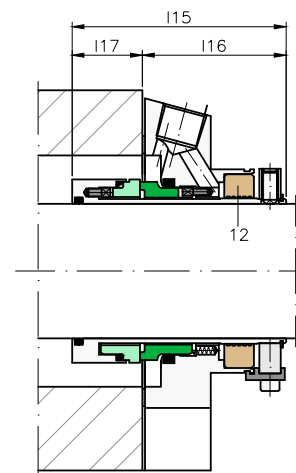

LSC40-FQGAB : ANSI BIG BORE
LSC40-FQGAS : ANSI STANDARD BORE

Single cartridge with connections for quench and flush between the faces, with a non-pressurised fluid. The quench fluid sealing is done through a throttle ring PTFE carbon-graphite reinforced. For applications using fluids with scant lubrication.



CHARACTERISTICS:

- Balanced.
- Multispring.
- Not dependent on the rotation direction.
- Flushing connections.

OPERATING LIMITS:

$d_1 = 50 \div 150 \text{ mm}$ $p = 10 \text{ kg/cm}^2$

$v = 10 \text{ m/s}$ $t = -40 \div +150^\circ\text{C}$ (*)

(*) The temperature resistance depends on the material of the secondary seals used.

The operating limits are defined by the PV factor which is determined for the sealing system characteristics and those of the application.

DESCRIPTION:

A Split single cartridge with connection for flushing.

For applications where is necessary to replace braided packing and there is enough space in the installation or the removal of the pump is very complex and requires a large investment of time.

Each half is placed around the shaft. They are joined by screws, without dismantling the pump.

CONNECTIONS (R):

From 50 mm to 82,55 mm: 3/8" NPT.

From 88,9 mm to 150 mm: 1/2" NPT.

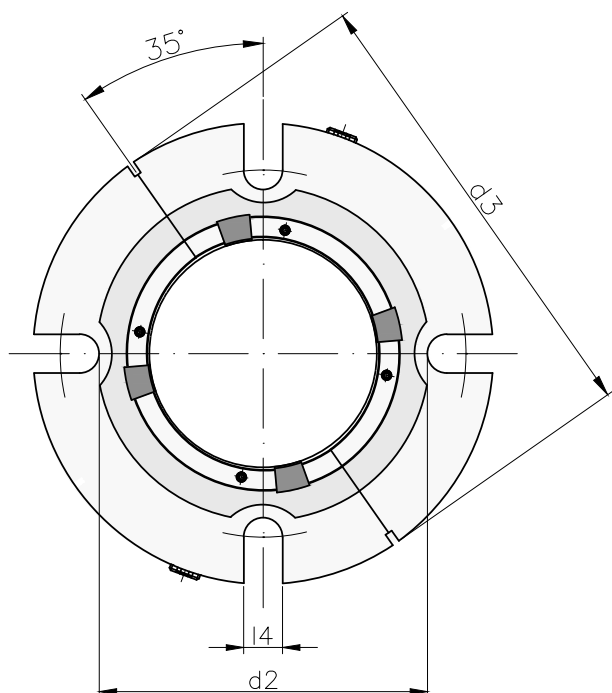

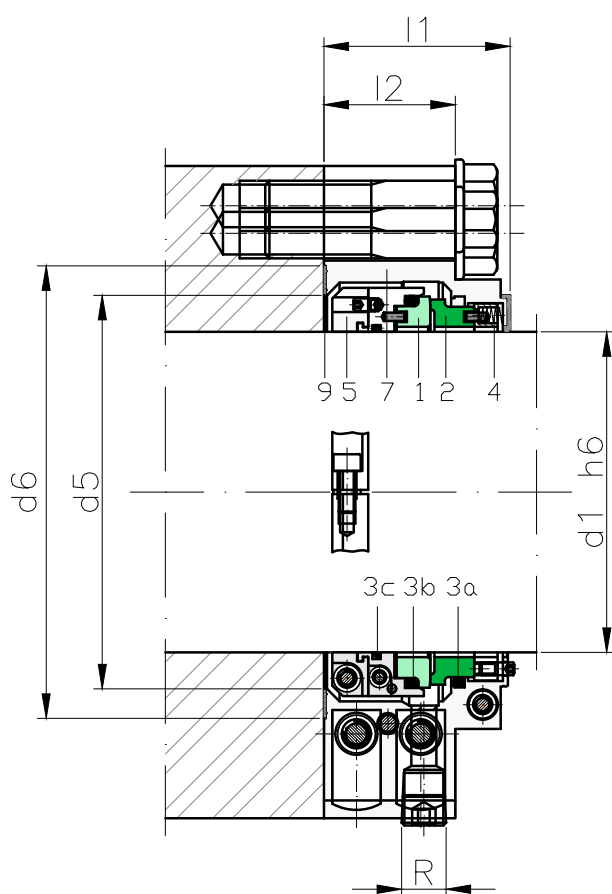

COMPONENTS:

- 1 Rotating contact surface
- 2 Stationary contact surface
- 3a O-ring
- 3b O-ring
- 3c O-ring
- 4 Springs
- 5 Metal frame
- 7 Flange
- 9 Flat gasket

DIMENSIONS CHART

Dimensions in inches

Shaft		d ₂	d ₃	d ₅	d ₆	l ₁	l ₂	l ₄
(")	mm							
2,00	50,8	87,7	138	75	84	62,9	45	15
2,15	54	92	147	79	88	62,9	45	15
2,375	60,3	105	149	89	101	64	46	17,5
2,50	63,5	108,5	157	92,5	104,5	64	46	17,5
2,75	69,8	118	176	98	113	64	46	20
3,00	76,2	127	192	107	122	65	47	20
3,25	82,5	135	191	110	132	65	47	20
3,50	89	145	203	121	140	72,4	50,5	22
3,75	95,2	148	206	125	143	72,4	50,5	22
4,00	101,6	155	216	131	150	72,4	50,5	22
4,25	108	170	230	142	165	72,4	50,5	22
4,50	114,3	180	240	152	175	72,4	50,5	22
4,75	120,6	180	240	152	175	72,4	50,5	22
5,00	127	190	268	162	185	89,5	62,5	26
5,50	139,7	205	303	175	200	89,5	62,5	26
6,00	152,4	220	308	188	215	89,5	62,5	26

Dimensions subject to changes or modifications.

DIMENSIONS CHART

Dimensions in mm

Shaft		d ₂	d ₃	d ₅	d ₆	l ₁	l ₂	l ₄
mm								
50	88	138	75	84	63	45	15	
60	105	149	89	101	64	46	17,5	
70	118	176	98	113	64	46	20	
80	135	191	110	132	65	47	20	
90	145	203	121	140	72,5	50,5	22	
100	155	216	131	150	72,5	50,5	22	
110	170	230	142	165	72,5	50,5	22	
120	180	240	152	175	72,5	50,5	22	
125	190	268	162	185	89,5	62,5	26	
140	205	303	175	200	89,5	62,5	26	
150	220	308	188	215	89,5	62,5	26	

Dimensions subject to changes or modifications.



CHARACTERISTICS:

- Balanced.
- Welded metal bellows.
- Not dependent on the rotation direction.

OPERATING LIMITS:

$$d_1 = 24 \div 95 \text{ mm} \quad p = 20 \text{ kg/cm}^2$$

$$v = 25 \text{ m/s} \quad t = -40 \div +200^\circ\text{C} (*)$$

(*) The temperature resistance depends on the material of the secondary seals used.

The operating limits are defined by the PV factor which is determined for the sealing system characteristics and those of the application.

DESCRIPTION:

Single cartridge in which the rotating part has a metal bellows. Adequate for applications with extremely viscous, sticky, particle-laden fluids.

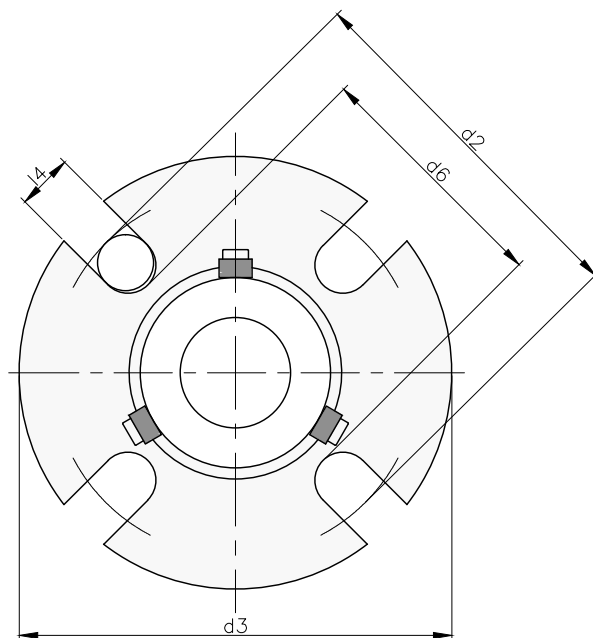

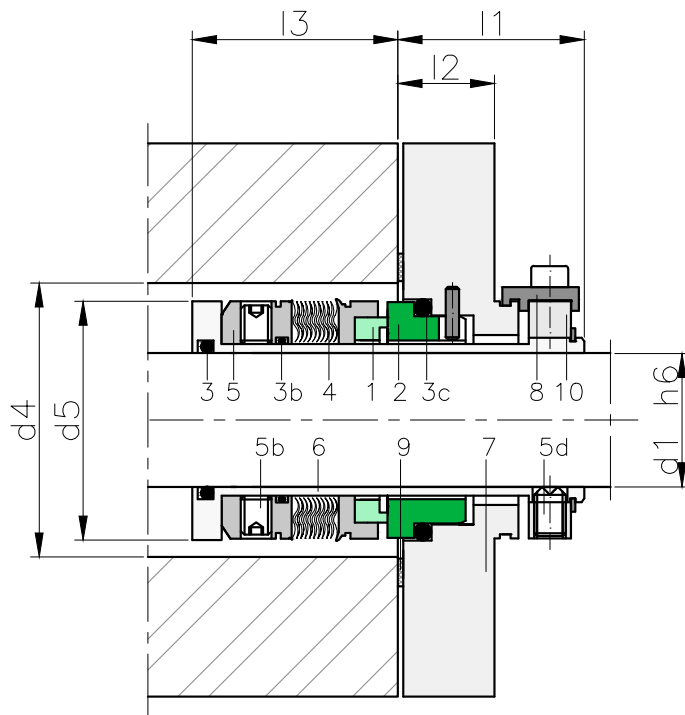

COMPONENTS:

- 1 Rotating contact surface
- 2 Stationary contact surface
- 3 O-rings
- 4 Metal bellows
- 5 Metal frame
- 5b Set screws
- 6 Sleeve
- 7 Flange
- 8 Setting clips
- 9 Flat gasket
- 10 Drive ring

DIMENSIONS CHART

Dimensions in mm

Shaft											
mm	d ₂ min.	d ₂ max.	d ₃	d ₄ min.	d ₄ max.	d ₅	d ₆	l ₁	l ₂	l ₃	l ₄
24	72	93	105	44	52	43	60	32	21	41	12
25	72	93	105	44	52	43	60	32	21	41	12
28	72	93	105	49	52	47	60	32	21	41	12
30	76	98	110	49	56	48	64	32	21	41	12
32	77	98	110	51	57	50	65	32	21	41	12
33	81.5	103	115	57	61.5	55	69.5	32	21	43.5	12
35	81.5	103	115	57	61.5	55	69.5	32	21	43.5	12
38	86	108	120	62	66	60	74	32	21	42	12
40	88	108	120	62	68	60	76	32	21	42	12
43	90.5	123	135	67	70.5	65	78.5	32	21	42	12
45	93	123	135	67	73	65	81	32	21	42	12
48	98	123	135	74	78	70	86	32	21	45.5	12
50	100	123	135	74	78	70	88	32	21	45.5	12
55	111	134	150	82	85	81	95	32	21	50.5	16
60	121	130	150	87	91	86	101	32	21	50.5	20
65	128.5	140	160	93	98.5	91	108.5	32	21	57	20
70	138	155	175	100	108	99	118	32	21	57	20
75	148	170	190	105	118	104	128	32	21	57	20
80	154	170	190	111	124	109	134	32	21	57	20
85	158	170	190	116	128	114	138	32	21	62	20
90	165	195	215	121	135	119	145	32	21	63	20
95	168	195	215	126	138	124	148	32	21	63	20

Dimensions subject to changes or modifications.



CHARACTERISTICS:

- Balanced.
- Multispring.
- Not dependent on the rotation direction.
- Stuffing box gland shape.
- Flush and drain connections.

OPERATING LIMITS:

$$d_f = 25 \div 70 \text{ mm} \quad p = 20 \text{ kg/cm}^2$$

$$v = 11.2 \text{ m/s} \quad t = -15 \div +200^\circ\text{C} (*)$$

(*) The temperature resistance depends on the material of the secondary seals used.

The operating limits are defined by the PV factor which is determined for the sealing system characteristics and those of the application.

DESCRIPTION:

Cartridge cast flange with a stuffing box gland shape for replacing packing in pumps.

The springs are protected from the product to prevent the blocking in applications with particle-laden fluids. The flange has two connections, one for flushing and cleaning the faces, and the another is a drain to clean the springs and also to control the small leaks.

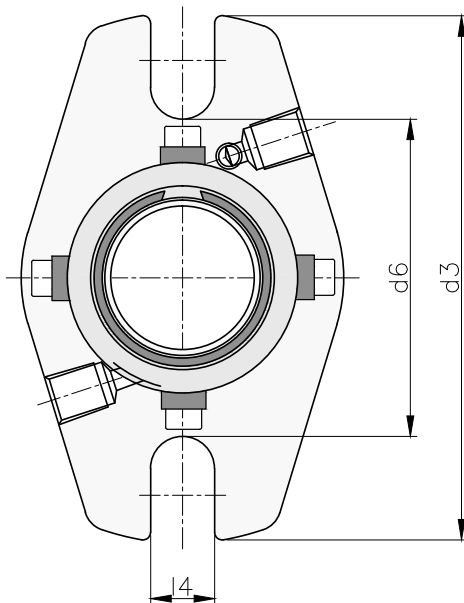

CONNECTIONS (R):

From 25 mm to 70 mm: 1/8" NPT.

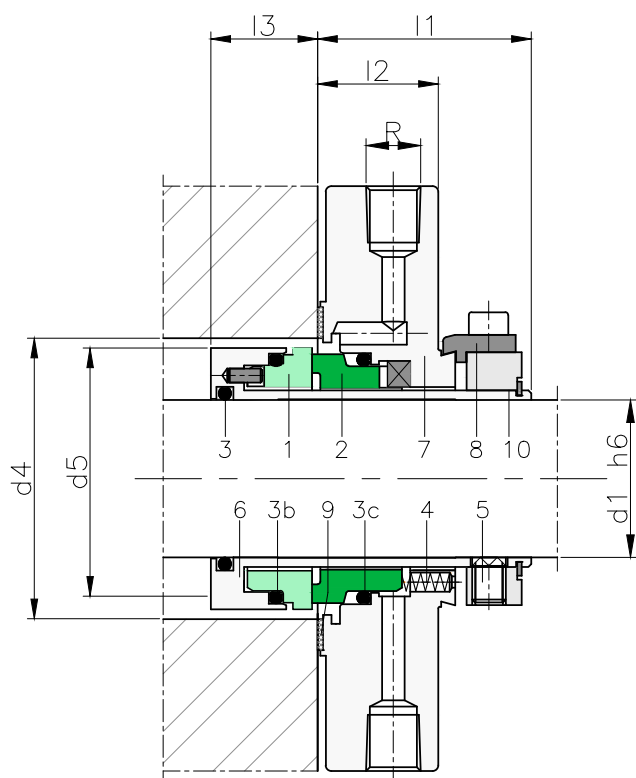

COMPONENTS:

- 1 Rotating contact surface
- 2 Stationary contact surface
- 3 O-rings
- 4 Springs
- 5 Set screws
- 6 Sleeve
- 7 Flange
- 8 Setting clips
- 9 Flat gasket
- 10 Drive ring

DIMENSIONS CHART

Dimensions in mm

Shaft									
mm	d ₃	d ₄ min.	d ₄ max.	d ₅	d ₆	l ₁	l ₂	l ₃	l ₄
25	104	49	58	43,5	62	38	21,5	19	12,5
28	104	50	58	46,5	63	38	21,5	19	12,5
30	104	52	61	48,5	65	38	21,5	19	12,5
32	102	54	59	51,5	67	38	21,5	19	12,5
33	104	54	62	51,5	67	38	21,5	19	12,5
35	115	57	65	53,5	70	38	21,5	19	12,5
38	125	62	71	56,5	75	38	21,5	19	14,7
40	125	62	71	58,5	75	38	21,5	19	14,7
42	133	66	75	60,5	79	38	21,5	19	14,7
43	133	67	76	61,5	80	38	21,5	19	14,7
45	140	68	77,5	63,5	81	38	21,5	19	14,7
48	140	71	80	66,5	84	38	21,5	19	14,7
50	140	74	83	68,5	87	38	21,5	19	14,7
53	150	77	86	71,5	90	38	21,5	19	17,5
55	150	79	88	73,5	92	38	21,5	19	17,5
58	155	82	91	76,5	95	38	21,5	19	17,5
60	160	87	96	78,5	100	38	21,5	19	17,5
63	165	90	99	81,5	103	38	21,5	19	17,5
65	165	92	101	83,5	105	38	21,5	19	17,5
68	170	97	105	86,5	110	38	21,5	19	17,5
70	180	107	115,5	88,5	120	38	21,5	19	17,5

Shaft										
(")	mm	d ₃	d ₄ min	d ₄ max	d ₅	d ₆	l ₁	l ₂	l ₃	l ₄
1,000	25,40	104	49	58	46,5	62	38	21,5	19	12,5
1,125	28,58	104	52	61	48,5	62	38	21,5	19	12,5
1,250	31,75	104	54	62	51,5	67	38	21,5	19	12,5
1,375	34,93	115	57	65	53,5	70	38	21,5	19	12,5
1,500	38,10	125	62	71	56,5	75	38	21,5	19	14,7
1,625	41,28	133	66	75	60,5	79	38	21,5	19	14,7
1,750	44,45	140	68	77,5	63,5	81	38	21,5	19	14,7
1,875	47,63	140	71	80	66,5	84	38	21,5	19	14,7
2,000	50,80	150	77	86	71,5	92	38	21,5	19	17,5
2,125	53,98	150	79	88	73,5	92	38	21,5	19	17,5
2,250	57,15	155	82	91	76,5	95	38	21,5	19	17,5
2,375	60,33	160	87	96	78,5	100	38	21,5	19	17,5
2,500	63,50	165	90	99	81,5	103	38	21,5	19	17,5
2,625	66,68	170	97	105	86,5	110	38	21,5	19	17,5
2,750	69,85	180	107	115,5	88,5	120	38	21,5	19	17,5

Dimensions subject to changes or modifications.



CHARACTERISTICS:

- Balanced.
- Not dependent on the rotation direction.

OPERATING LIMITS:

$p = 25 \text{ kg/cm}^2$

$v = 20 \text{ m/s}$

$t = -20 \div +140^\circ\text{C} (*)$

(*) The temperature resistance depends on the material of the secondary seals used.

The operating limits are defined by the PV factor which is determined for the sealing system characteristics and those of the application.

DESCRIPTION:

A compact single cartridge that is fixed to the shaft and to the flange, with no additional elements. Designed to prevent changes in pressure from opening the contact surfaces.

COMPONENTS:

- 1p Rotating contact surface
- 2p Stationary contact surface
- 3 O-rings
- 4 Springs
- 6 Sleeve
- 7 Housing Stationary part
- 8 Locking fixture

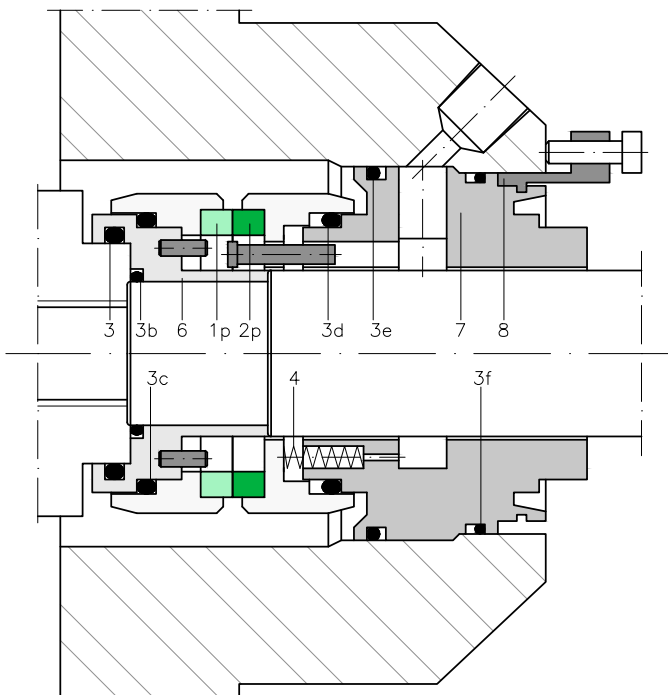



DOUBLE CARTRIDGE
DOUBLE CARTRIDGE
DOUBLE CARTRIDGE...

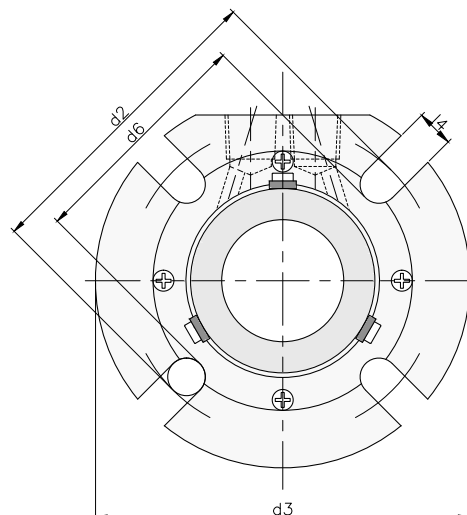

CHARACTERISTICS:

- Balanced.
- Multispring.
- Not dependent on the rotation direction.
- Barrier fluid connections.

OPERATING LIMITS:

$$d_1 = 25 \div 120 \text{ mm} \quad p = 20 \text{ kg/cm}^2$$

$$v = 20 \text{ m/s} \quad t = -15 \div +200^\circ\text{C} (*)$$

(*) The temperature resistance depends on the material of the secondary seals used.

The operating limits are defined by the PV factor which is determined for the sealing system characteristics and those of the application.

DESCRIPTION:

A double cartridge seal with a "back to back" arrangement which permits operation with barrier fluids in excessive pressure conditions with respect to the working fluid ($P_1 + 1.5 \sim 2 \text{ kg/cm}^2$).

For this reason it is advisable to install it in applications with toxic, contaminant or potentially dangerous fluids in where safety is an important factor.

CONNECTIONS (R):

3/8" NPT.
For 25, 28 and 30 mm shafts the connections are at opposite sides of the flange.

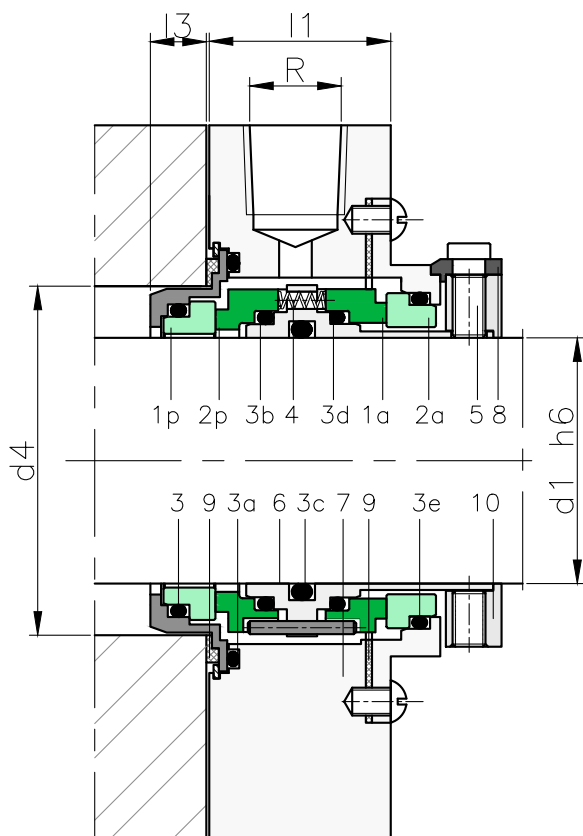

COMPONENTS:

- | | |
|------------------------------------------------|-----------------|
| 1p Stationary contact surface product side | 5 Set screws |
| 2p Rotating contact surface product side | 6 Sleeve |
| 1a Rotating contact surface atmospheric side | 7 Flange |
| 2a Stationary contact surface atmospheric side | 8 Setting clips |
| 3 O-rings | 9 Flat gasket |
| 4 Springs | 10 Drive ring |

DIMENSIONS CHART

Dimensions in mm

Shaft								
mm	d ₂	d ₃	d ₄ min	d ₄ max	d ₆	l ₁	l ₃	l ₄
25	79,5	116,1	44,5	50,8	67,2	58,0	10	16
28	80,5	119,1	47,6	54,0	68,2	58,0	10	16
30	85,9	122,4	50,8	57,2	73,5	58,0	10	16
35	89,4	125,5	54,0	60,3	77,1	58,0	10	16
38	94,2	128,8	57,2	63,5	81,9	58,0	10	16
40	95,8	131,8	60,3	66,7	83,4	58,0	10	16
45	98,8	135,1	63,5	69,9	82,5	58,0	10	16
48	101,9	138,2	66,7	73,0	85,5	58,0	10	16
50	107,2	141,5	69,9	76,2	90,8	58,0	10	16
53	115,1	144,5	73,0	79,4	98,5	58,0	10	16
55	115,1	144,5	73,0	79,4	98,5	58,0	10	16
58	117,6	147,8	76,2	82,6	101,3	58,0	10	16
60	121,2	150,9	82,6	85,7	104,8	58,0	10	16
63	124,5	154,2	85,7	88,9	--	58,0	10	16
65	139,2	164,9	92,1	95,3	120,3	67,6	10	20
68	142,2	168,2	95,3	98,4	--	67,6	10	20
70	146,1	171,5	98,4	101,6	127,1	67,6	10	20
75	148,6	174,5	101,6	104,8	129,6	67,6	10	20
80	151,9	177,6	104,8	108,0	132,9	67,6	10	20
85	158,2	183,9	111,1	114,3	139,2	67,6	10	20
90	161,3	187,2	114,3	117,5	142,3	67,6	10	20
95	167,6	193,6	120,7	123,8	148,6	67,6	10	20
100	174,0	199,9	127,0	130,2	155,0	67,6	10	20
105	177,3	203,0	130,2	133,4	--	67,6	10	20
110	181,4	209,3	136,5	139,7	--	67,6	10	20
115	184,7	212,6	139,7	142,9	--	67,6	10	20
120	193,0	219,0	146,1	149,2	--	67,6	10	20

Dimensions subject to changes or modifications.

Dimensions in inches

Shaft								
(")	mm	d ₂	d ₃	d ₄ min	d ₄ max	l ₁	l ₃	l ₄
1,000	25,4	79,5	116,1	44,5	50,8	49,3	11,4	15,9
1,125	28,6	80,5	119,1	47,6	54,0	49,3	11,4	15,9
1,250	31,8	85,9	122,4	50,8	57,2	49,3	11,4	15,9
1,375	34,9	89,4	125,5	54,0	60,3	62,0	11,4	15,9
1,500	38,1	94,2	128,8	57,2	63,5	62,0	11,4	15,9
1,625	41,3	95,8	131,8	60,3	66,7	62,0	11,4	15,9
1,750	44,5	98,8	135,1	63,5	69,9	62,0	11,4	15,9
1,875	47,6	101,9	138,2	66,7	73,0	62,0	11,4	15,9
2,000	50,8	107,2	141,5	69,9	76,2	62,0	11,4	15,9
2,125	54,0	115,1	144,5	73,0	79,4	62,0	11,4	15,9
2,250	57,2	117,6	147,8	76,2	82,6	62,0	11,4	15,9
2,375	60,3	121,2	150,9	82,6	85,7	62,0	11,4	15,9
2,500	63,5	124,5	154,2	85,7	88,9	62,0	11,4	15,9
2,625	66,7	142,2	164,8	92,1	95,3	67,6	11,4	19,1
2,750	69,9	145,5	168,1	95,3	98,4	67,6	11,4	19,1
2,875	73,0	148,6	171,2	98,4	101,6	67,6	11,4	19,1
3,000	76,2	151,9	174,5	101,6	104,8	67,6	11,4	19,1
3,125	79,4	154,9	177,5	104,8	108,0	67,6	11,4	19,1
3,250	82,6	158,2	180,8	108,0	111,1	67,6	11,4	19,1
3,375	85,7	161,3	183,9	111,1	114,3	67,6	11,4	19,1
3,500	88,9	164,6	187,2	114,3	117,5	67,6	11,4	19,1
3,625	92,1	167,6	190,2	117,5	120,7	67,6	11,4	19,1
3,750	95,3	170,9	193,5	120,7	123,8	67,6	11,4	19,1
3,875	98,4	174,0	196,6	123,8	127,0	67,6	11,4	19,1
4,000	101,6	177,3	199,9	127,0	130,2	67,6	11,4	19,1
4,125	104,8	180,3	202,9	130,2	133,4	67,6	11,4	19,1
4,250	108,0	181,4	206,2	133,4	136,5	67,6	11,4	19,1
4,375	111,1	184,7	209,3	136,5	139,7	67,6	11,4	19,1
4,500	114,3	187,7	212,6	139,7	142,9	67,6	11,4	19,1
4,625	117,5	191,0	215,6	142,9	146,1	67,6	11,4	19,1
4,750	120,7	196,1	218,9	146,1	149,2	67,6	11,4	19,1

Dimensions subject to changes or modifications.



CHARACTERISTICS:

- Balanced.
- Welded metal bellows.
- Not dependent on the rotation direction.
- Barrier fluid connections.

OPERATING LIMITS:

$d_1 = 25 \div 85 \text{ mm}$ $p = 20 \text{ kg/cm}^2$

$v = 20 \text{ m/s}$ $t = -15 \div +200^\circ\text{C}$ (*)

(*) The temperature resistance depends on the material of the secondary seals used.

The operating limits are defined by the PV factor which is determined for the sealing system characteristics and those of the application.

DESCRIPTION:

Double cartridge seal with a “tandem” arrangement suitable for working with pressurised or non-pressurised barrier fluids.

The metal bellows design has a self-cleaning effect that prevents particles from building up inside it.

This model is recommended in extremely demanding applications: with high-viscosity fluids, sticky fluids, particle-laden fluids, fluids with few lubricating and/or pollutant properties and in high temperature applications.

Highly reliable cartridge.

CONNECTIONS (R):

From 25 mm to 65 mm: 1/4" NPT.

From 70 mm to 85 mm: 3/8" NPT.

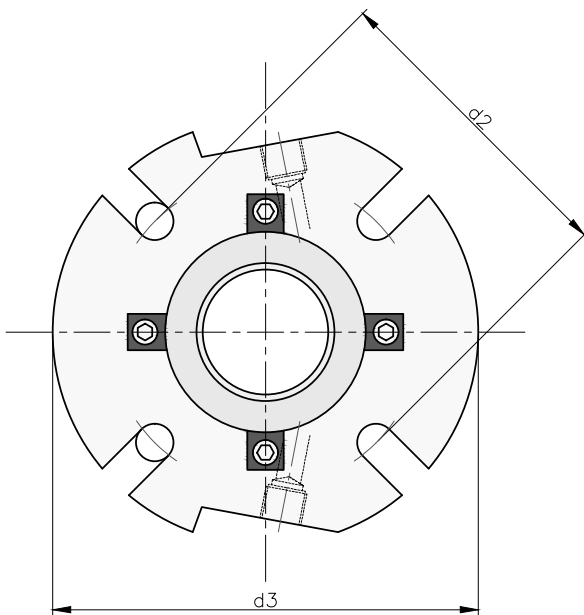

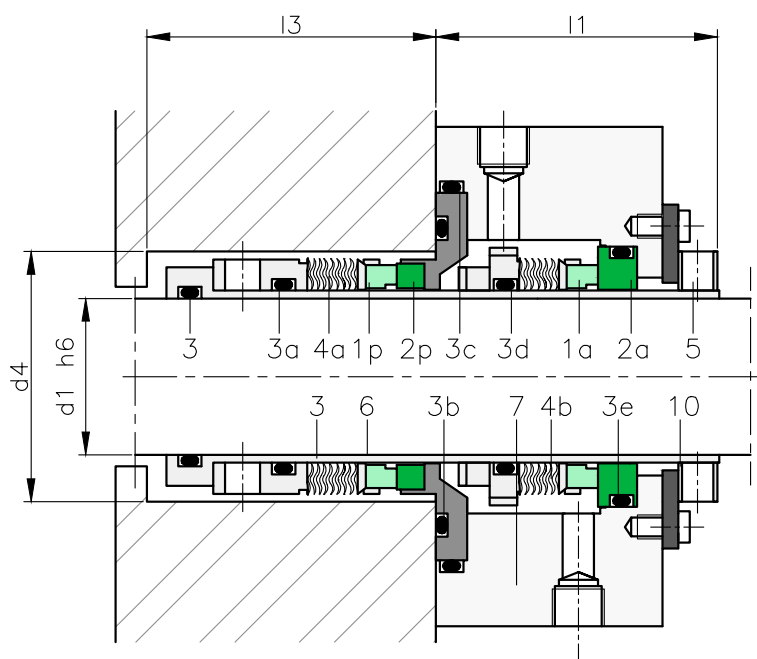

COMPONENTS:

- 1p Rotating contact surface product side
- 2p Stationary contact surface product side
- 1a Rotating contact surface atmospheric side
- 2a Stationary contact surface atmospheric side
- 3 O-rings
- 4 Metal bellows
- 5 Set screws
- 6 Sleeve
- 7 Flange
- 8 Setting clips
- 9 Flat gasket
- 10 Drive ring

DIMENSIONS CHART

Dimensions in mm

Shaft							
mm	d ₃	d ₄ min	d ₄ max.	d ₆	l ₁	l ₃	l ₄
25	105	44,5	47,8	64	52,3	51,6	12,7
28	108	44,5	47,8	64	52,3	51,6	12,7
32	108	50,8	54,1	67	54,1	52,3	12,7
35	108	50,8	55,6	73	51,6	52,3	12,7
38	114,3	57,2	60,5	79,3	54,1	57,2	14,3
45	139,7	63,5	65	82,6	54,1	59,4	14,3
48	139,7	66,8	68,3	85,7	54,1	59,4	14,3
50	139,7	69,9	74,7	92,3	54,1	59,4	14,3
55	152,4	76,2	81	98,4	54,1	61	18
58	158,8	79,5	81	98,4	54,1	61	18
60	158,8	82,6	87,4	101,7	57,2	58,7	18
63	165,1	85,9	87,4	106	55,6	61	18
65	165	89	92	106	57,2	58	18
85	203	113	116	135	64	61	22

Dimensions in inches

Shaft								
(")	mm	d ₃ mm	d ₄ min	d ₄ max.	d ₆ mm	l ₁ mm	l ₃ mm	l ₄ mm
1,000	25,40	104,9	44,5	47,8	64,0	52,3	51,6	12,7
1,130	28,58	108,0	44,5	47,8	64,0	52,3	51,6	12,7
1,250	31,75	108,0	50,8	54,1	67,0	54,1	52,3	12,7
1,380	34,93	108,0	50,8	55,6	73,0	51,6	52,3	12,7
1,500	38,10	114,3	57,2	60,5	79,3	54,1	57,2	14,3
1,630	41,28	127,0	60,5	63,5	80,9	54,1	56,1	14,3
1,750	44,45	139,7	63,5	65,0	82,6	54,1	59,4	14,3
1,880	47,63	139,7	66,8	68,3	95,7	54,1	59,4	14,3
2,000	50,80	139,7	69,9	74,7	92,3	54,1	59,4	14,3
2,130	53,98	152,4	76,2	81,0	98,4	54,1	61,0	18,0
2,250	57,15	158,8	79,5	81,0	98,4	54,1	61,0	18,0
2,380	60,33	158,8	82,6	87,4	101,7	57,2	58,7	18,0
2,500	63,50	165,1	85,9	87,4	106,0	55,6	61,2	18,0

Dimensions subject to changes or modifications.



CHARACTERISTICS:

- Balanced.
- Multispring.
- Not dependent on the rotation direction.
- Barrier fluid, purge and drain connections.

OPERATING LIMITS:

$d_1 = 25 \div 140 \text{ mm}$ $p = 20 \text{ kg/cm}^2$

$v = 25 \text{ m/s}$ $t = -15 \div +200^\circ\text{C}$ (*)

(*) The temperature resistance depends on the material of the secondary seals used.

The operating limits are defined by the PV factor which is determined for the sealing system characteristics and those of the application.

DESCRIPTION:

Double cartridge seal with a "tandem" arrangement suitable for working with pressurised or non-pressurised barrier fluids. Recommended in applications in which a high level of safety is required.

Possibility of incorporating a pumping ring to reduce the temperature gradient between the mechanical seal contact surfaces.

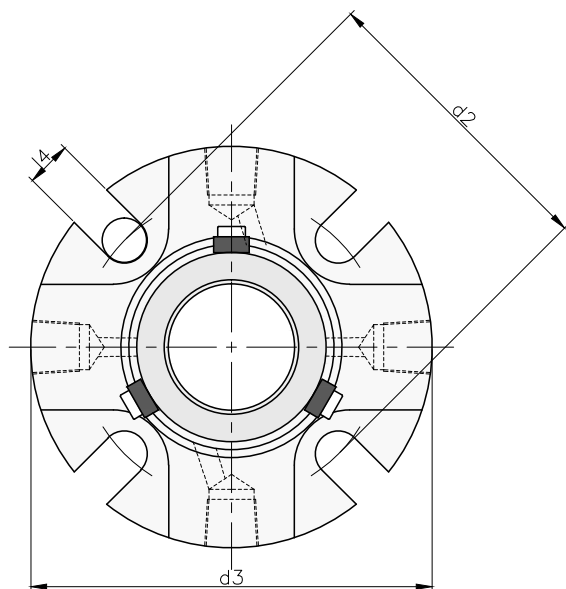

CONNECTIONS (R):

From 25 mm to 60 mm: 1/4" NPT.
From 63 mm to 110 mm: 3/8" NPT.

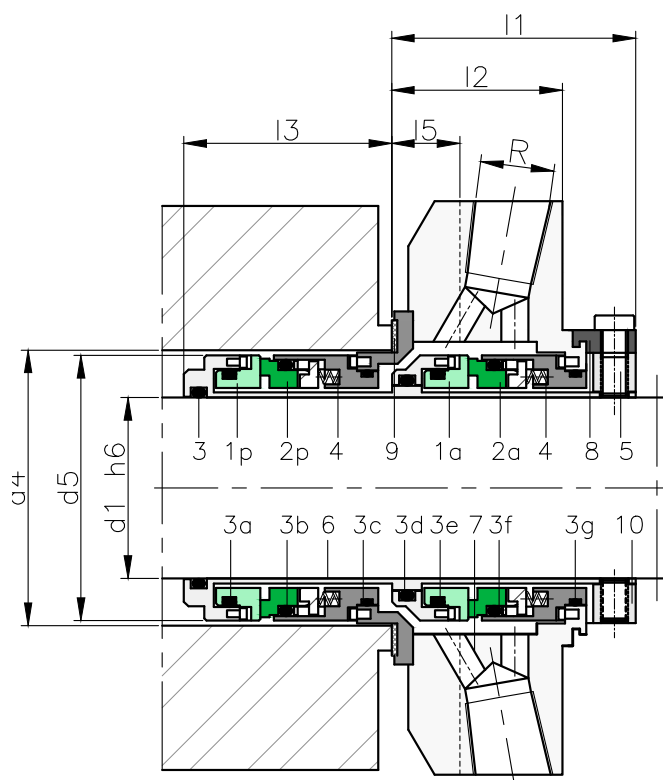

COMPONENTS:

- 1p Rotating contact surface product side
- 2p Stationary contact surface product side
- 1a Rotating contact surface atmospheric side
- 2a Stationary contact surface atmospheric side
- 3 O-rings
- 4 Springs
- 5 Set screws
- 6 Sleeve
- 7 Flange
- 8 Setting clips
- 9 Flat gasket
- 10 Drive ring

DIMENSIONS CHART

Dimensions in mm

Shaft										
mm	d ₂	d ₃	d ₄ min	d ₄ max	d ₅	l ₁	l ₂	l ₃	l ₄	l ₅
25	71.2	101.6	41.3	48.0	39.7	49.6	34.4	44.5	13.3	13.5
28	74.5	104.8	44.5	51.2	42.9	52.4	36.7	45.4	13.3	13.5
30	79.9	108.0	46.1	56.5	44.5	52.4	36.7	45.4	13.3	13.5
32	81.6	108.0	47.6	58.3	46.0	52.4	36.7	45.4	13.3	13.5
33	84.8	111.1	50.8	61.5	49.3	52.4	36.7	45.4	13.3	13.5
35	84.8	111.1	50.8	61.5	49.3	52.4	36.7	45.4	13.3	13.5
38	91.4	123.8	57.2	68.1	55.5	54.0	37.8	47.5	13.3	15.1
40	95.7	127.0	60.3	71.4	58.7	54.0	37.8	47.5	14.3	15.1
43	98.4	133.4	63.0	74.1	61.1	54.0	37.8	47.5	14.3	15.1
45	98.4	133.4	63.0	74.1	61.1	54.0	37.8	47.5	14.3	15.1
48	98.4	133.4	66.7	74.1	64.7	54.0	37.8	47.5	14.3	15.1
50	101.6	139.7	70.0	76.6	67.9	58.7	40.7	51.9	14.3	27.0
53	113.5	148.8	73.0	85.3	71.1	58.7	40.7	51.9	17.4	15.1
55	113.5	148.8	75.0	85.3	72.9	58.7	40.7	51.9	17.4	15.1
58	116.0	165.1	76.2	88.5	74.2	58.7	40.7	51.9	17.4	15.1
60	119.9	165.1	79.4	91.7	77.4	62.6	43.6	52.8	17.4	15.9
63	127.0	171.5	85.7	98.8	83.8	65.1	43.6	50.3	17.4	15.9
65	127.0	171.5	85.7	98.8	83.8	65.1	43.6	50.3	17.4	15.9
68	131.3	171.5	92.1	103.2	90.2	63.5	41.3	53.2	17.4	15.9
70	131.3	171.5	92.1	103.2	90.2	63.5	41.3	53.2	17.4	15.9
75	145.3	196.9	101.6	113.5	98.1	65.1	45.4	51.6	20.6	17.4
80	148.5	188.9	105.0	116.8	102.2	63.8	40.5	55.3	20.6	40.5
85	154.8	206.4	111.1	123.2	107.9	65.1	40.5	54.0	20.6	40.5
90	158.6	212.7	117.5	129.5	114.3	65.1	40.5	54.0	17.5	40.5
95	172.0	222.3	120.0	132.1	117.5	65.1	40.5	54.0	17.5	40.5
100	171.7	228.6	127.0	139.7	123.8	65.1	40.5	54.0	20.6	40.5
105	174.9	228.6	130.2	142.9	127.0	65.1	40.5	54.0	20.6	40.5
110	184.4	241.3	139.7	152.4	136.5	65.1	40.5	54.0	20.6	40.5
115	184.4	241.3	146.1	152.4	136.5	65.1	40.5	54.0	20.6	40.5
120	192.4	263.5	146.1	160.4	142.9	65.1	40.5	54.0	20.6	40.5
125	254.0	304.8	171.7	184.4	155.6	77.3	44.4	62.8	20.6	44.4
130	260.4	311.2	178.1	190.8	161.9	77.3	44.4	62.8	20.6	44.4
135	266.7	322.3	190.5	203.2	168.3	77.3	44.4	62.8	20.8	44.4
140	266.7	322.3	190.5	203.2	168.3	77.3	44.4	62.8	20.8	44.4

Dimensions subject to changes or modifications.



CHARACTERISTICS:

- Balanced.
- Multispring.
- Not dependent on the rotation direction.
- Barrier fluid connections.

OPERATING LIMITS:

$$d_1 = 25 \div 100 \text{ mm} \quad p = 25 \text{ kg/cm}^2$$

$$v = 16 \text{ m/s} \quad t = -15 \div +200^\circ\text{C} (*)$$

(*) The temperature resistance depends on the material of the secondary seals used.

The operating limits are defined by the PV factor which is determined for the sealing system characteristics and those of the application.

DESCRIPTION:

A double cartridge with a "face to face" arrangement which permits operation with barrier fluid in excessive pressure with respect to the working fluid ($P_1 + 1.5 - 2 \text{ Kgr/cm}^2$)

The sleeve includes a pumping ring that facilitate the barrier fluid movement. The connections of Liquid barrier IN and OUT have to be connected according the rotation direction.

CONNECTIONS (R):

From 25 mm to 35 mm: 1/4" NPT.
From 38 mm to 100 mm: 3/8" NPT.

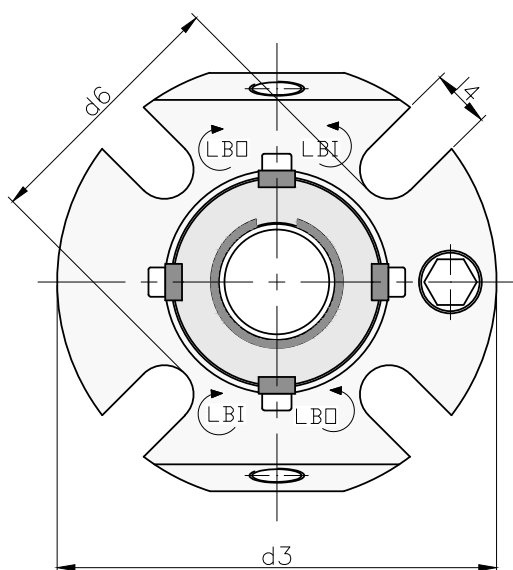

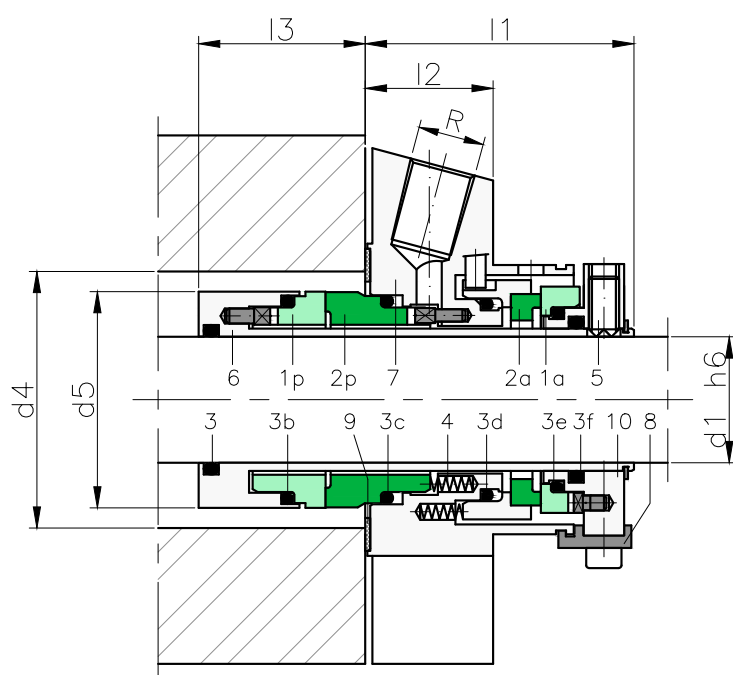

COMPONENTS:

- 1p Rotating contact surface product side
- 2p Stationary contact surface product side
- 1a Rotating contact surface atmospheric side
- 2a Stationary contact surface atmospheric side
- 3 O-rings
- 4 Springs
- 5 Set screws
- 6 Sleeve
- 7 Flange
- 8 Setting clips
- 9 Flat gasket
- 10 Drive ring

DIMENSIONS CHART

Dimensions in mm

Shaft										
mm	d ₃	d ₄ min.	d ₄ máx.	d ₅	d ₆	l ₁	l ₂	l ₃	l ₄	
25	105	44	51,5	43	62	53,4	25,4	33,1	13,2	
28	105	47	52	46	61	53,4	25,4	33,1	13,2	
30	105	49	56	48	67	53,4	25,4	33,1	13,2	
32	108	51	57	49,8	70	53,4	25,4	33,1	13,2	
33	108	51	57	49,8	70	53,4	25,4	33,1	13,2	
35	113	54	61,5	53	72	53,4	25,4	33,1	13,2	
38	123	57	66	56	75	53,4	25,4	33,1	13,2	
40	123	59	68	58	77	53,4	25,4	33,1	14,2	
42	133	62	69,5	61	80	53,4	25,4	33,1	14,2	
43	133	62	70,5	61	80	53,4	25,4	33,1	14,2	
45	138	64	73	61	82	53,4	25,4	33,1	14,2	
48	138	67	75	65,6	85	53,4	25,4	33,1	14,2	
50	148	69	78	68	87	53,4	25,4	33,1	14,2	
53	148	73	87	72	97	53,4	25,4	33,1	18	
55	148	74	83	73	92	53,4	25,4	33,1	18	
60	157	79	91	78	102	53,4	25,4	33,1	18	
65	163	85,7	98,5	84,8	109	53,4	25,4	33,1	18	
70	178	95	108	93	118	53,4	25,4	33,1	18	
75	190	101,6	118	100	129	63,9	28	44,1	18	
80	195	108	124	106,4	135	63,9	28	44,1	18	
85	198	111,1	128	109,5	139	63,9	28	44,1	22	
90	205	117,5	135	115,9	145	63,9	28	44,1	22	
95	208	120,7	138	119,1	148	63,9	28	44,1	22	
100	218	127	144	125,4	154	63,9	28	44,1	22	

Dimensions in inches

Shaft										
(")	mm	d ₃	d ₄ min	d ₄ máx	d ₅	d ₆	l ₁	l ₂	l ₃	l ₄
1,000	25,4	105,0	44,0	51,0	43,0	62,0	53,4	25,4	33,1	13,2
1,125	28,6	105,0	47,6	52,1	46,0	61,0	53,4	25,4	33,1	13,2
1,250	31,8	110,0	51,0	57,0	49,8	70,1	53,4	25,4	33,1	13,2
1,375	34,9	113,0	56,3	61,5	53,0	72,1	53,4	25,4	33,1	13,2
1,500	38,1	123,0	57,0	66,0	56,0	74,9	53,4	25,4	33,1	13,2
1,625	41,3	123,0	60,3	68,6	59,5	78,5	53,4	25,4	33,1	14,2
1,750	44,5	138,0	64,0	73,0	62,5	82,0	53,4	25,4	33,1	14,2
1,875	47,6	138,0	67,0	75,0	65,6	85,1	53,4	25,4	33,1	14,2
2,000	50,8	148,0	69,0	78,0	68,0	87,1	53,4	25,4	33,1	14,2
2,125	53,98	148,0	73,0	87,0	72,0	97,0	53,4	25,4	33,1	18,0
2,250	57,2	157,0	76,2	90,4	75,2	100,1	53,4	25,4	33,1	18,0
2,375	60,3	157,0	79,4	91,0	78,0	102,1	53,4	25,4	33,1	18,0
2,500	63,5	163,0	83,8	96,5	81,6	106,2	53,4	25,4	33,1	18,0
2,625	66,7	163,0	85,7	100,0	84,8	109,3	53,4	25,4	33,1	18,0
2,750	69,9	178,0	95,0	108,0	93,0	118,4	53,4	25,4	33,1	18,0
2,875	73,0	190,0	101,6	118,0	100,0	129,0	108,0	25,4	44,1	18,0
3,000	76,2	190,0	101,6	118,0	100,0	129,0	108,0	28,0	44,1	18,0
3,125	79,4	195,0	108,0	124,0	106,4	135,0	108,0	28,0	44,1	18,0
3,250	82,6	195,0	108,0	124,0	106,4	135,0	108,0	28,0	44,1	18,0
3,375	85,7	198,0	111,1	128,0	109,5	139,0	108,0	28,0	44,1	22,0
3,500	88,9	198,0	114,3	140,1	112,7	142,0	108,0	28,0	44,1	22,0
3,625	92,1	205,0	117,5	135,0	115,9	145,0	108,0	28,0	44,1	22,0
3,750	95,3	208,0	120,7	138,0	119,1	148,0	108,0	28,0	44,1	22,0
4,000	101,6	218,0	127,0	144,0	125,4	154,0	108,0	28,0	44,1	22,0

Dimensions subject to changes or modifications.



CHARACTERISTICS:

- Balanced.
- Multispring.
- Not dependent on the rotation direction.
- Barrier fluid connections.

OPERATING LIMITS:

$$d_1 = 25,4 \div 95,3 \text{ mm} \quad p = 25 \text{ kg/cm}^2$$

$$v = 16 \text{ m/s} \quad t = -15 \div +200^\circ\text{C} (*)$$

(*) The temperature resistance depends on the material of the secondary seals used.

The operating limits are defined by the PV factor which is determined for the sealing system characteristics and those of the application.

DESCRIPTION:

A double cartridge with a "face to face" arrangement which permits operation with barrier fluid in excessive pressure with respect to the working fluid ($P_1 + 1.5 - 2 \text{ Kgr/cm}^2$)

The sleeve, include a pumping ring that facilitate the barrier fluid movement. The connections of Liquid barrier IN and OUT have to be connected according the rotation direction.

Recommended for flange pumps ANSI BIG BORE
ANSI STANDARD BORE

CONNECTIONS (R):

From 25,4 mm to 34,9 mm: 1/4" NPT.

From 38,1 mm to 95,3 mm: 3/8" NPT.

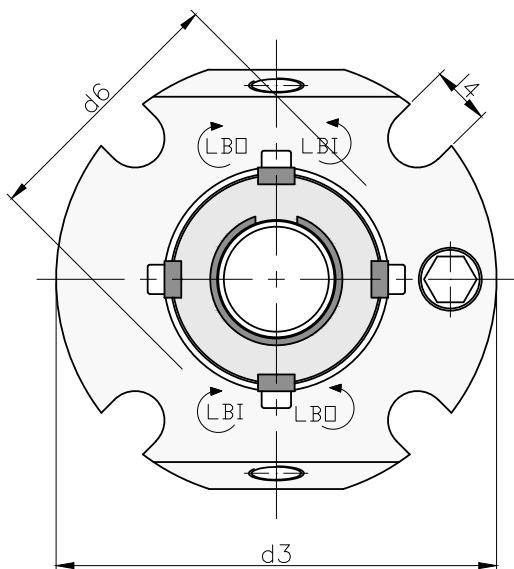

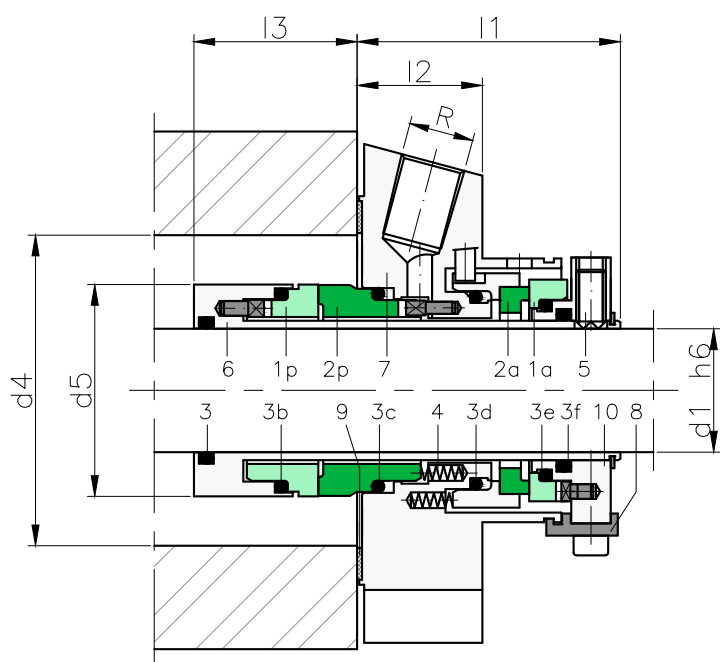

COMPONENTS:

- 1p Rotating contact surface product side
- 2p Stationary contact surface product side
- 1a Rotating contact surface atmospheric side
- 2a Stationary contact surface atmospheric side
- 3 O-rings
- 4 Springs
- 5 Set screws
- 6 Sleeve
- 7 Flange
- 8 Setting clips
- 9 Flat gasket
- 10 Drive ring

DIMENSIONS CHART ANSI STANDARD BORE
LDC40-AS Dimensions in inches

Shaft											
(")	mm	d ₃	d ₄ min.	d ₄ max.	d ₅	d ₆	l ₁	l ₂	l ₃	l ₄	
1,000	25,4	100	44	56	43	62	53,4	25,4	33,1	11	
1,125	28,6	105,0	44,5	56	43,5	62	82	25,4	34,1	11,1	
1,250	31,8	108,0	51	61	50	70	53,4	25,4	33,1	11	
1,375	34,9	107,0	50,8	61	49,8	70	52,9	25,4	33,1	11,1	
1,500	38,1	114,0	57	69	55,9	75	53,4	25,4	33,1	14	
1,625	41,3	125,0	61,5	71	59,4	78,5	53,4	25,4	33,1	14	
1,750	44,5	130,0	63,5	75	62,5	82	53,4	25,4	33,1	14,2	
1,875	47,6	130,0	67,6	78	65,6	84	53,4	25,4	33,1	14	
2,000	50,8	139,0	70	81	68	87	53,4	25,4	33,1	16	
2,125	54,0	140,0	74	91	72	97	53,4	25,4	33,1	16,5	
2,250	57,2	149,0	77,2	91	75,2	98	53,4	25,4	33,1	16,5	
2,375	60,3	157,0	79,4	91,2	78	25,4	53,4	25,4	25,4	18	
2,500	63,5	170,0	83,6	100	81,6	115	53,4	28,5	33,1	18	
2,625	66,7	162,0	86,8	102	84,8	115	53,4	31,8	33,1	16	
2,750	69,9	189,0	95	111	93	118	53,4	32	33,1	18	
3,000	76,2	199,0	102	120	100	127	63,9	32	44,1	18	
3,250	82,6	198,9	108,4	125	106,4	135	63,9	32	44,1	18	
3,750	95,3	208	120,7	138	119,1	25,4	25,4	25,4	25,4	22	

Dimensions subject to changes or modifications.

DIMENSIONS CHART ANSI BIG BORE
LDC40-AB Dimensions in inches

Shaft											
(")	mm	d ₃	d ₄ min.	d ₄ max.	d ₅	d ₆	l ₁	l ₂	l ₃	l ₄	
1,000	25,4	--	--	--	--	--	--	--	--	--	
1,125	28,6	114,3	44,5	71	43,5	84,1	47,9	25,4	34,1	11,1	
1,250	31,8	--	--	--	--	--	--	--	--	--	
1,375	34,9	130	50,8	81	49,8	90	52,9	25,4	33,6	11,1	
1,500	38,1	--	--	--	--	--	--	--	--	--	
1,625	41,3	--	--	--	--	--	--	--	--	--	
1,750	44,5	165	63,5	103	62,5	116	52,9	25,4	33,6	14,2	
1,875	47,6	152	67,6	100	65,6	112	52,9	25,4	33,6	14	
2,000	50,8	159	70	116	68	124	53,4	32	33,1	14	
2,125	54,0	175	74	115	72	134	53,4	25,4	33,1	18	
2,250	57,2	163	78,6	112	75,2	119	53,4	32,4	33,1	18	
2,500	63,5	198	83,8	134	81,6	140	53,4	31,8	33,1	18	
2,625	66,7	175	80,5	130	84,8	136	53,4	31,8	33,1	18	
2,750	69,9	190	95	133	93	140	53,4	32,4	33,1	16	
3,000	76,2	209	102	140	100	150	63,9	32,4	33,1	16	
3,250	82,6	--	--	--	--	--	--	--	--	--	



CHARACTERISTICS:

- Balanced.
- Not dependent on the rotation direction.
- Barrier fluid connections.

OPERATION LIMITS:

$p = 25 \text{ kg/cm}^2$

$v = 16 \text{ m/s}$

$t = -15 \div +200^\circ\text{C} (*)$

(*) The temperature resistance depends on the material of the secondary seals used.

The operating limits are defined by the PV factor which is determined for the sealing system characteristics and those of the application.

COMPONENTS:

- 1a Stationary contact surface atmospheric side
- 1p Rotating contact surface product side
- 2a Rotating contact surface atmospheric side
- 2p Stationary contact surface product side
- 3 O-rings
- 4 Springs
- 5 Sleeve
- 6 Sleeve
- 7 Housing Stationary part
- 8 Locking fixture

DESCRIPTION:

Double cartridge in which the contact surfaces are lubricated by an external, non-pressurised fluid (quench) or a pressurised fluid (barrier fluid). For clean or slightly contaminated and sticky fluids with fibres or large solid particles.

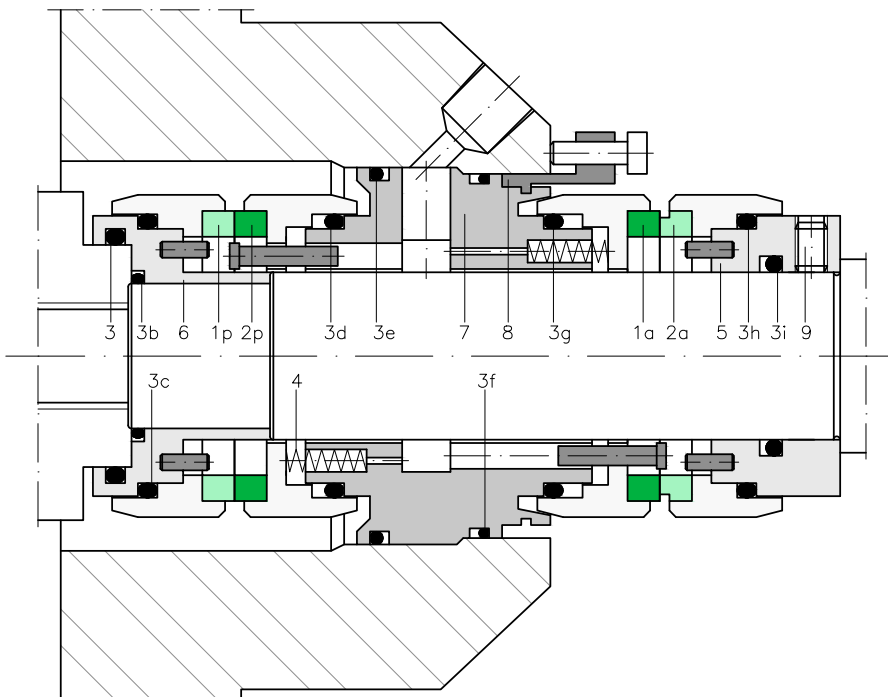



AGITATORS AND REACTORS...



CHARACTERISTICS:

- Balanced.
- Not dependent on the rotation direction.
- Multispring.

OPERATING LIMITS:

$p=$ 50 kg/cm²

$v=$ 50 m/s

$t=$ -20 ÷ +140°C (*)

(*) The temperature resistance depends on the material of the secondary seals used.

The operating limits are defined by the PV factor which is determined for the sealing system characteristics and those of the application.

DESCRIPTION:

Balanced mechanical seal with protected springs to prevent them from blocking when in contact with sticky or viscous fluids.

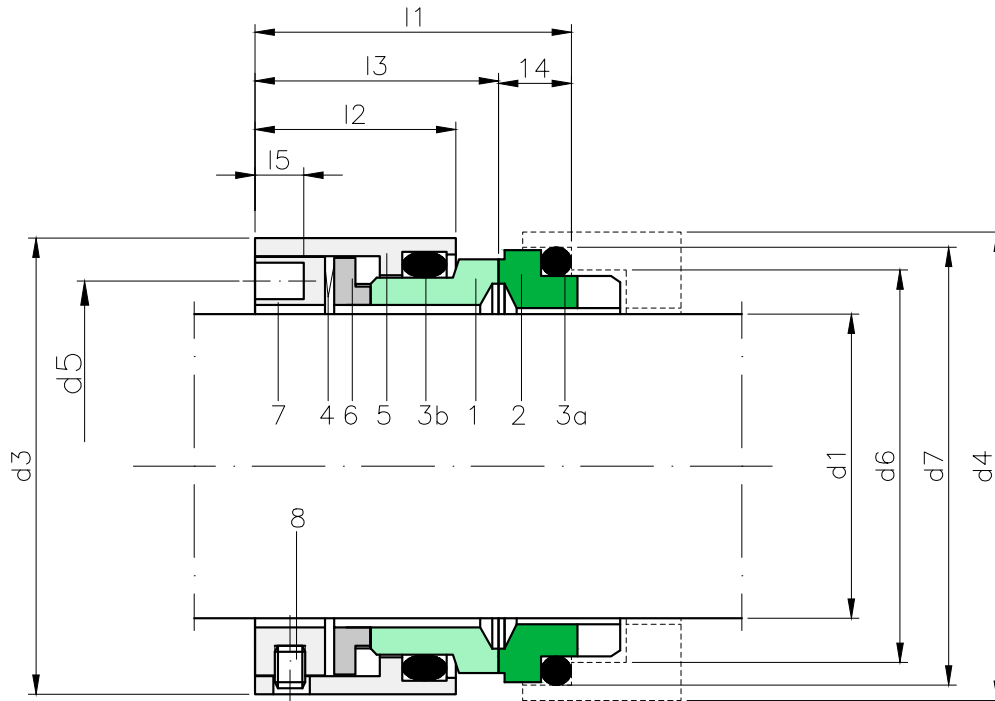

DIMENSIONS CHART

Dimensions in mm

Shaft										
mm	d_3	d_4	d_5	d_6	d_7	l_1	l_2	l_3	l_4	l_5
40	65	64	52	53.5	59	48.5	30	39	9.5	5
50	75	77	61	63.5	72	54.5	33	42.2	12.3	5
53	80	80	64	66.5	75	55	33.5	42.7	12.3	5
55	85	85	68	71.5	80	60	36.5	47.2	12.8	5
60	90	90	74	76.5	85	61.5	38	48.7	12.8	5
65	95	95	78	81.5	90	62	38	49.2	12.8	5
80	115	119	98	102	110.5	63.5	38	50	13.5	5

Dimensions subject to changes or modifications.

COMPONENTS:

- 1 Rotating contact surface
- 2 Stationary contact surface
- 3a O-ring
- 4 Spring
- 5 Metal frame
- 6 Ring
- 7 Metal frame
- 8 Setting clips

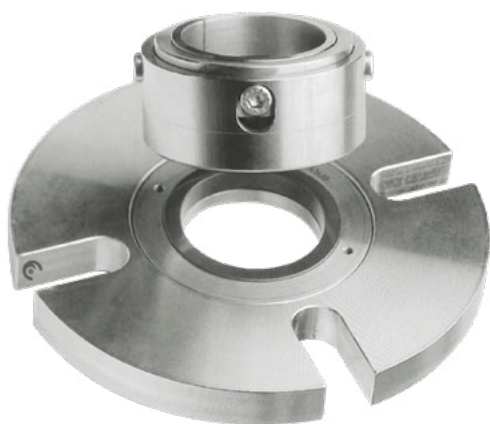

CHARACTERISTICS:

- Balanced.
- System attached to the shaft by allen screws
- Not dependent on the rotation direction.
- External mounting.

OPERATING LIMITS:

$d_1 = 25 \div 160 \text{ mm}$ $p = \text{vacuum to } 6 \text{ kg/cm}^2$

$v = 2 \text{ m/s}$ $t = -20 \div +150^\circ\text{C} (*)$

(*) The temperature resistance depends on the material of the secondary seals used.

The operating limits are defined by the PV factor which is determined for the sealing system characteristics and those of the application.

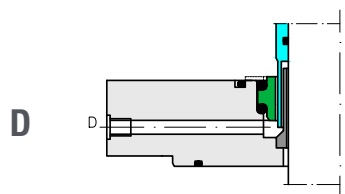
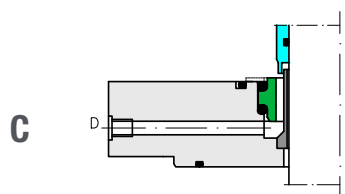
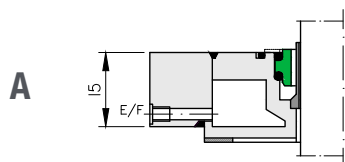

A Type A: Cooling flange. It can also be used as a heating flange ($T_{\text{max}} = +350^\circ\text{C}$)

C Leakage drain. It can also be used alternatively as a flush.

D Polymerisation barrier. It can also be used alternatively as a leakage drain or a flush.

DESCRIPTION:

Multispring mechanical seal for vertical agitators with moderate speeds. The stationary part can use lubrications systems: flush connection or/and refrigeration flange.

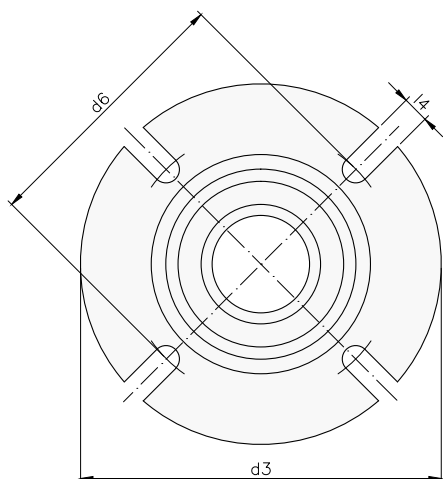

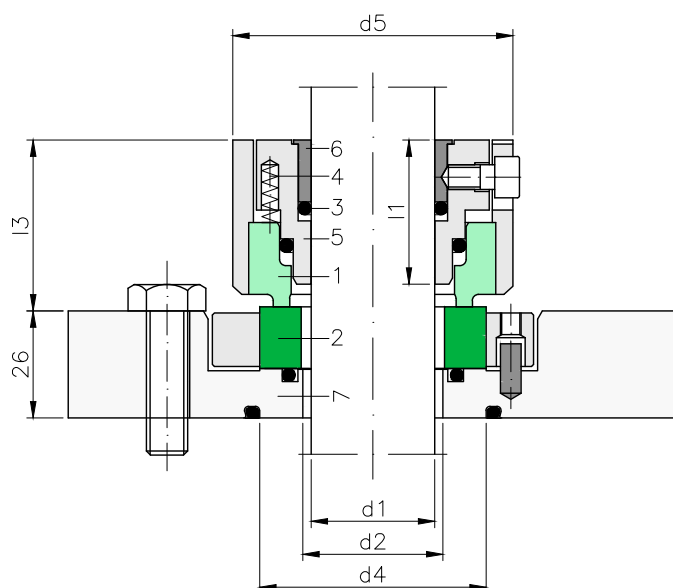

COMPONENTS:

- 1 Rotating contact surface
- 2 Stationary contact surface
- 3 O-ring
- 4 Muelles
- 5 Metal frame
- 6 Drive ring
- 7 Flange

DIMENSIONS CHART

Dimensions in mm and inches

Shaft		Rotatory part			Stationary part					
(")	mm	l_1	l_3	d_5	d_2	d_3	d_4	$d_{6_{min}}$	$d_{6_{max}}$	l_4
1,000	25	40,5	41,5	68	34	148	-	100	132	11
1,125	28	40,5	41,5	68	34	148	55	100	132	11
-	30	40,5	41,5	68	34	148	55	100	132	11
1,250	32	40,5	41,5	73	39	153	60	105	137	11
1,375	35	40,5	41,5	73	39	153	60	105	137	11
1,500	38	40,5	41,5	78	44	158	65	110	142	11
-	40	40,5	41,5	78	44	158	65	110	142	11
1,625	45	40,5	41,5	83	49	163	68	115	152	11
1,750	-	40,5	41,5	83	49	163	68	115	152	11
1,875	48	40,5	41,5	88	54	178	73	125	160	14
1,125	50	40,5	41,5	88	54	178	75	125	160	14
2,000	55	40,5	41,5	93	59	183	78	130	165	14
2,125	-	40,5	41,5	93	59	183	78	130	165	14
2,250	60	40,5	41,5	98	64	188	85	135	170	14
2,375	65	40,5	44,5	103	69	193	90	140	175	14
2,500	-	40,5	44,5	103	69	193	90	140	175	14
6,625	70	43,5	44,5	108	74	198	95	145	180	14
2,750	-	43,5	44,5	108	74	198	95	145	180	14
2,875	75	43,5	44,5	113	79	203	100	150	185	14
3,000	80	43,5	44,5	118	84	208	105	155	190	14
3,250	85	43,5	44,5	123	89	213	110	160	195	14
3,500	90	43,5	44,5	128	94	218	115	165	200	14
3,750	95	43,5	44,5	133	99	223	120	170	205	14
-	100	43,5	44,5	138	104	228	125	175	210	14
4,000	105	43,5	44,5	143	109	233	130	180	215	14
4,250	110	43,5	44,5	148	114	238	135	185	220	14
4,500	115	43,5	44,5	153	119	267	140	196	243	18
4,750	125	43,5	44,5	163	129	277	150	206	253	18
5,000	140	43,5	44,5	178	144	297	165	221	273	18
5,250	-	43,5	44,5	178	144	297	165	221	273	18
5,500	-	43,5	44,5	178	144	297	165	221	273	18
5,750	150	43,5	44,5	188	154	307	175	231	283	18
6,000	160	43,5	44,5	198	164	317	185	241	283	18
6,250	-	43,5	44,5	198	164	317	185	241	283	18

Dimensions subject to changes or modifications.



CHARACTERISTICS:

- Balanced.
- System attached to the shaft by allen screws
- Not dependent on the rotation direction.
- External mounting.

OPERATING LIMITS:

$d_1 = 25 \div 175 \text{ mm}$ $p = 15 \text{ kg/cm}^2$

$v = 2 \text{ m/s}$ $t = -20 \div +200^\circ\text{C}$ (*)

(*) The temperature resistance depends on the material of the secondary seals used.

The operating limits are defined by the PV factor which is determined for the sealing system characteristics and those of the application.

DESCRIPTION:

It can be used in vertical agitators with moderate speeds without the need to apply auxiliary lubrication systems. Adapted to DEBRIS cleaning systems.

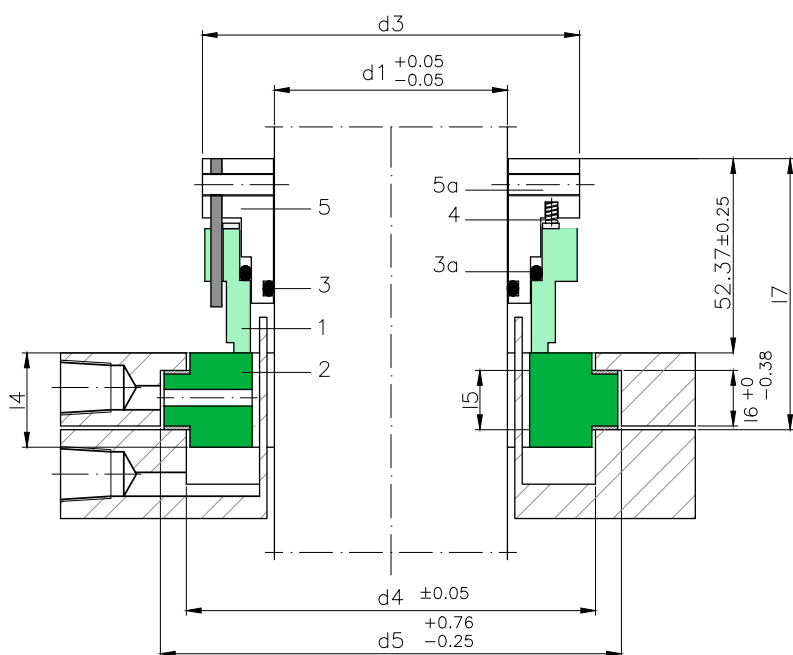

COMPONENTS:

- 1 Rotating contact surface
- 2 Stationary contact surface
- 3 O-ring
- 3a O-ring
- 4 Spring
- 5 Metal frame
- 5a Drive ring

DIMENSIONS CHART

Dimensions in mm

Shaft mm	Rotatory part d ₃	Stationary part					
		d ₄	d ₅	l ₄	l ₅	l ₆	l ₇
25	63,5	47,6	57,9	20,6	12,7	11,9	69,0
28	66,6	50,8	61,1	20,6	12,7	11,9	69,0
30	69,8	53,9	67,5	22,2	12,7	11,9	69,0
32	69,8	53,9	67,5	22,2	12,7	11,9	69,0
33	73,0	57,1	70,6	22,2	12,7	11,9	69,0
35	73,0	57,1	70,6	22,2	12,7	11,9	69,0
38	76,2	63,5	77,0	22,2	12,7	11,9	69,0
40	79,3	66,6	80,2	22,2	12,7	11,9	69,0
43	82,5	69,8	83,3	22,2	12,7	11,9	69,0
45	85,7	73,0	89,7	25,4	15,9	15,1	73,0
50	88,9	79,3	96,0	25,4	15,9	15,1	73,0
53	92,0	79,3	99,2	25,4	15,9	15,1	73,0
55	95,2	85,7	102,4	25,4	15,9	15,1	73,0
58	98,4	88,9	105,6	25,4	15,9	15,1	73,0
60	98,4	88,9	105,6	25,4	15,9	15,1	73,0
63	101,6	92,0	108,7	25,4	15,9	15,1	73,0
65	104,7	95,2	111,9	25,4	15,9	15,1	73,0
68	107,9	98,4	115,1	25,4	15,9	15,1	73,0
70	107,9	98,4	115,1	25,4	15,9	15,1	73,0
75	114,3	103,3	119,8	25,4	15,9	15,1	73,0
80	120,6	111,1	127,8	25,4	15,9	15,1	73,0
85	123,9	114,3	131,1	25,4	15,9	15,1	73,0
90	130,2	120,7	137,3	25,4	15,9	15,1	73,0
95	133,3	123,8	140,5	25,4	15,9	15,1	73,0
100	139,7	133,3	150,0	25,4	15,9	15,1	73,0
105	142,9	136,5	153,2	25,4	15,9	15,1	73,0
110	149,2	142,8	159,5	25,4	15,9	15,1	73,0
115	155,5	149,2	165,9	25,4	15,9	15,1	73,0

Dimensions in inches

Shaft (")	Rotatory part mm	d ₃	Stationary part					
			d ₄	d ₅	l ₄	l ₅	l ₆	l ₇
1.00	25.40	63.50	47.63	57.94	20.62	12.70	11.89	69.04
1.13	28.58	66.68	50.80	61.11	20.62	12.70	11.89	69.04
1.25	31.75	69.85	53.98	67.46	20.62	12.70	11.89	69.85
1.38	34.93	73.03	57.15	70.64	20.62	12.70	11.89	69.85
1.50	38.10	76.20	63.50	76.99	20.62	12.70	11.89	69.85
1.63	41.28	79.38	66.68	80.16	20.62	12.70	11.89	69.85
1.75	44.45	82.55	69.85	83.34	20.62	12.70	11.89	73.03
1.88	47.63	85.73	73.03	89.69	25.40	15.88	11.89	73.03
2.00	50.80	88.90	79.38	98.32	25.40	15.88	11.89	73.03
2.13	53.98	92.08	79.38	99.21	25.40	15.88	15.06	73.03
2.25	57.15	95.25	85.73	102.39	25.40	15.88	15.06	73.03
2.38	60.33	98.43	88.90	105.56	25.40	15.88	15.06	73.03
2.50	63.50	101.60	92.08	108.74	25.40	15.88	15.06	73.03
2.63	66.68	104.78	95.25	111.91	25.40	15.88	15.06	73.03
2.75	69.85	107.95	98.43	115.09	25.40	15.88	15.06	73.03
2.88	73.03	111.13	101.60	118.26	25.40	15.88	15.06	73.03
3.00	76.20	114.30	104.78	119.84	25.40	15.88	15.06	73.03
3.13	79.38	117.48	107.95	124.61	25.40	15.88	15.06	73.03
3.25	82.55	120.65	111.13	127.79	25.40	15.88	15.06	73.03
3.38	85.73	123.83	114.30	130.96	25.40	15.88	15.06	73.03
3.50	88.90	127.00	117.48	134.14	25.40	15.88	15.06	73.03
3.63	92.08	130.18	120.65	137.31	25.40	15.88	15.06	73.03
3.75	95.25	133.35	123.83	140.49	25.40	15.88	15.06	73.03
3.88	98.43	136.53	127.00	143.66	25.40	15.88	15.06	73.03
4.00	101.60	139.70	130.18	150.01	25.40	15.88	15.06	73.03
4.13	104.78	142.88	133.35	153.19	25.40	15.88	15.06	73.03
4.25	107.95	146.05	136.53	156.36	25.40	15.88	15.06	73.03
4.38	111.13	149.23	139.70	159.54	25.40	15.88	15.06	73.03
4.50	114.30	152.40	142.88	162.71	25.40	15.88	15.06	73.03

Dimensions subject to changes or modifications.



CHARACTERISTICS:

- Balanced.
- Multispring.
- Not dependent on the rotation direction.

OPERATING LIMITS:

$d_1 = 40 \div 220 \text{ mm}$ $p = 16 \text{ kg/cm}^2$

$v = 5 \text{ m/s}$ $t = -40 \div +300^\circ\text{C} (*)$

(*) The temperature resistance depends on the material of the secondary seals used.

The operating limits are defined by the PV factor which is determined for the sealing system characteristics and those of the application.

DESCRIPTION:

Single cartridge for a wide range of applications. It can be used with non-pressurised fluids (quench) or pressurised fluids (LST reservoir). This type of mount prevents leakage to the exterior.

Available with floating bearing. Dimensions in accordance with the DIN 28154 standard.

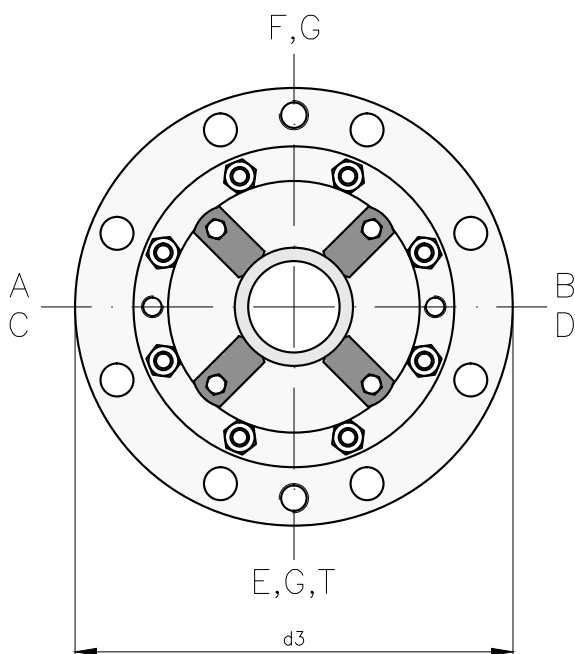

FLANGE COMPONENTS

- A: Barrier fluid quench IN
- B: Barrier fluid quench OUT
- C: Drainage
- D: Leakage drain G 1/8"
- E: Cooling IN G 3/8"
- F: Cooling OUT G 3/8"
- G: Grease
- T: Temperature metering

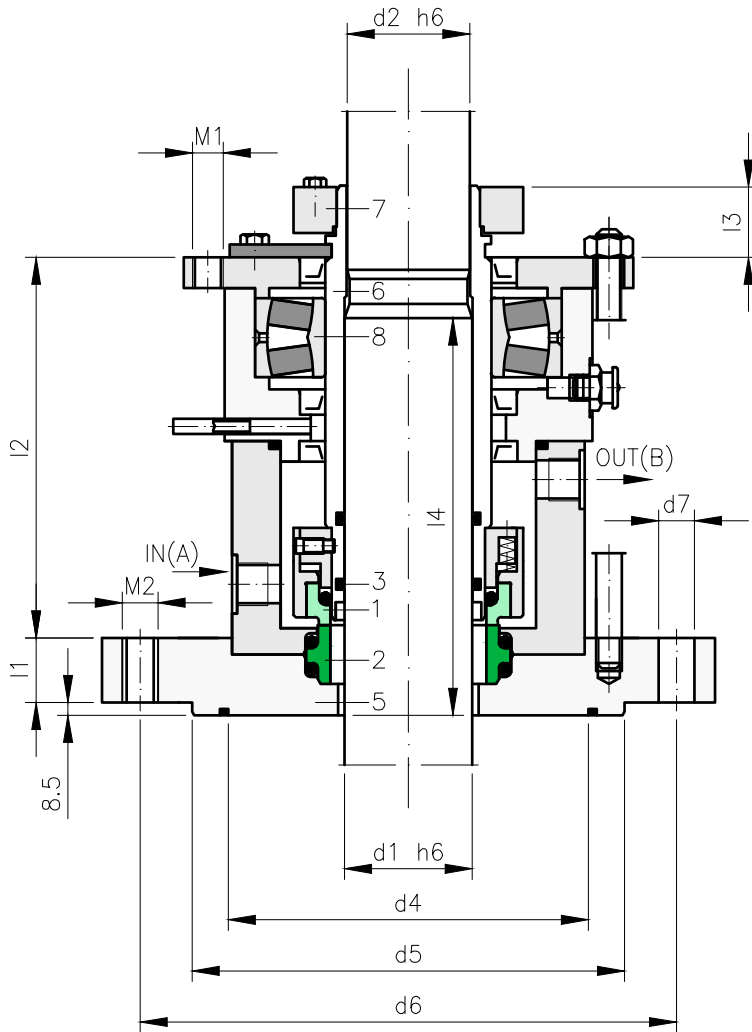

COMPONENTS:

- 1 Rotating contact surface
- 2 Stationary contact surface
- 3 O- ring
- 5 Flange
- 6 Sleeve
- 7 Drive rings
- 8 Bearings

DIMENSIONS CHART

Dimensions in mm

Shaft													
d ₁	d ₂	d ₃	d ₄	d ₅	d ₆	nxd ₇	l ₁	l ₂	l ₃	M ₁	M ₂	A, B	
40	38	175	90	110	145	4 x 18	15	136	28	M12	M16	G3/8	
50	48	240	135	176	210	8 x 18	17	149	28	M12	M16	G3/8	
60	58	240	135	176	210	8 x 18	17	156	28	M12	M16	G3/8	
80	78	275	155	204	240	8 x 22	20	189	34	M16	M20	G1/2	
100	98	305	190	234	270	8 x 22	20	190	34	M16	M20	G1/2	
125	120	330	215	260	295	8 x 22	20	205	40	M20	M20	G1/2	
140	135	395	250	313	350	12 x 22	20	222	40	M20	M20	G1/2	
160	150	395	265	313	350	12 x 22	25	219,5	40	M20	M20	G1/2	
180	170	445	310	364	400	12 x 22	25	230	45	M24	M20	G1/2	
200	190	445	310	364	400	12 x 22	25	237,5	45	M24	M20	G1/2	
220	210	505	340	422	460	16 x 22	25	249,5	50	M24	M20	G1/2	

Dimensions subject to changes or modifications.



CHARACTERISTICS:

- Balanced.
- Multispring.
- Not dependent on the rotation direction.
- Barrier fluid connections.

OPERATING LIMITS:

$$d_1 = 40 \div 220 \text{ mm} \quad p = 16 \text{ kg/cm}^2$$

$$v = 5 \text{ m/s} \quad t = -40 \div +300^\circ\text{C} (*)$$

(*) The temperature resistance depends on the material of the secondary seals used.

The operating limits are defined by the PV factor which is determined for the sealing system characteristics and those of the application.

DESCRIPTION:

Special double cartridge for reactors and agitators.

The internal structure "Back to Back" is continuously lubricated by a liquid barrier, which must be pressurized between 1.5 and 2 kg / cm² above the working fluid.

Flange connection for steel vessels DIN 28141, shaft end for steel vessels DIN 28154 and DIN 28136 glass-lined vessels.

Floating bearing included.

All LDC80 models are for unstopped shafts based on (DIN 28154). For stepless shafts, use the reference LDC81.

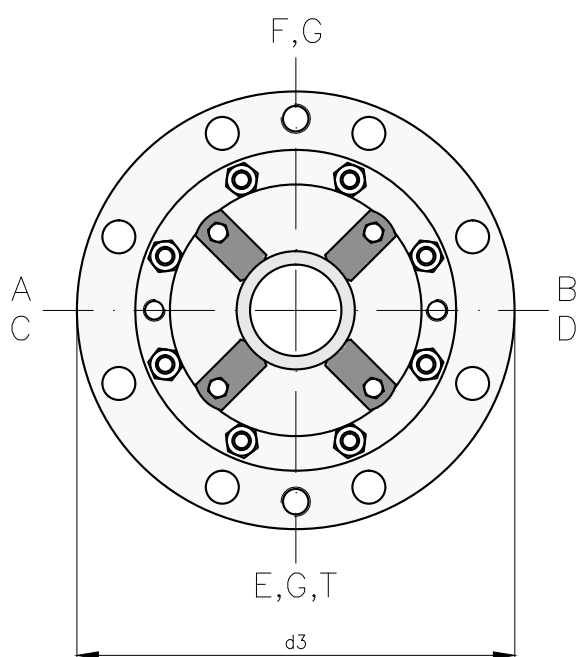

FLANGE COMPONENTS

- A: Barrier fluid quench IN
- B: Barrier fluid quench OUT
- C: Drainage
- D: Leakage drain G 1/8"
- E : Cooling IN G 3/8"
- F: Cooling OUT G 3/8"
- G: Grease
- T: Temperature metering

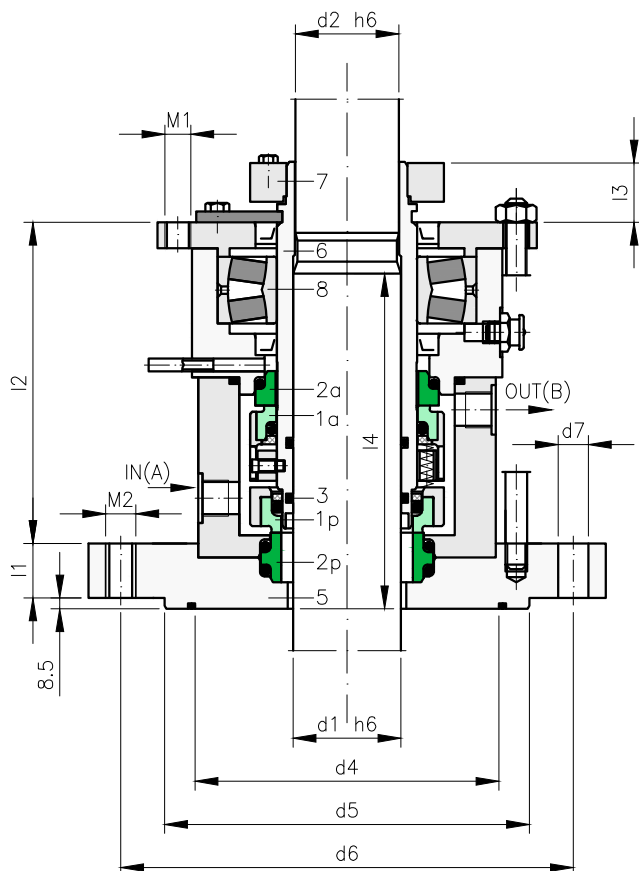

COMPONENTS:

- 1p Rotating contact surface product side
- 2p Stationary contact surface product side
- 1a Rotating contact surface atmospheric side
- 2a Stationary contact surface atmospheric side
- 3 O- ring
- 5 Flange
- 6 Sleeve
- 7 Drive rings
- 8 Bearings

DIMENSIONS CHART

Dimensions in mm

Shaft													
d ₁	d ₂	d ₃	d ₄	d ₅	d ₆	nxd ₇	l ₁	l ₂	l ₃	M ₁	M ₂	A,B	
40	38	175	90	110	145	4 x 18	15	136	28	M12	M16	G3/8	
50	48	240	135	176	210	8 x 18	17	149	28	M12	M16	G3/8	
60	58	240	135	176	210	8 x 18	17	156	28	M12	M16	G3/8	
80	78	275	155	204	240	8 x 22	20	189	34	M16	M20	G1/2	
100	98	305	190	234	270	8 x 22	20	190	34	M16	M20	G1/2	
125	120	330	215	260	295	8 x 22	20	205	40	M20	M20	G1/2	
140	135	395	250	313	350	12 x 22	20	222	40	M20	M20	G1/2	
160	150	395	265	313	350	12 x 22	25	219,5	40	M20	M20	G1/2	
180	170	445	310	364	400	12 x 22	25	230	45	M24	M20	G1/2	
200	190	445	310	364	400	12 x 22	25	237,5	45	M24	M20	G1/2	
220	210	505	340	422	460	16 x 22	25	249,5	50	M24	M20	G1/2	

Dimensions subject to changes or modifications.

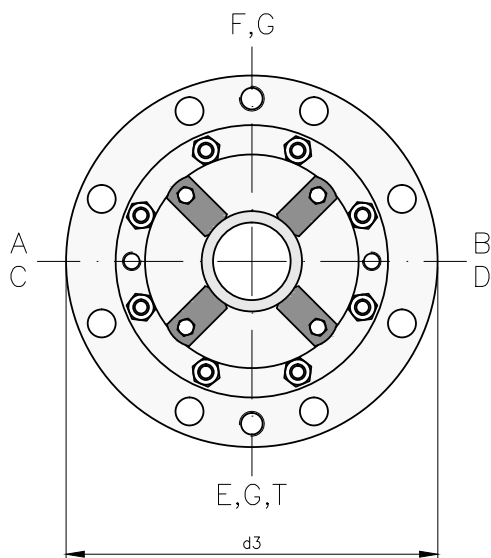

FLANGE COMPONENTS

- A: Barrier fluid quench IN
- B: Barrier fluid quench OUT
- C: Drainage
- D: Leakage drain G 1/8"
- E : Cooling IN G 3/8"
- F: Cooling OUT G 3/8"
- G: Grease
- T: Temperature metering

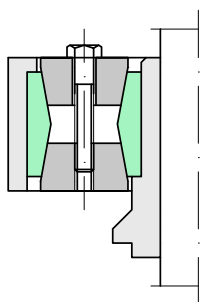

Clamping set (CS)

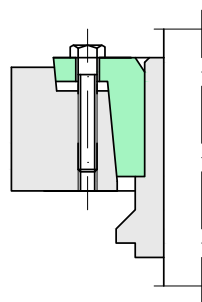

Shrink disk (SD)

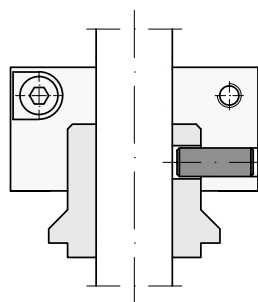

Clamping ring with pin (CRP)

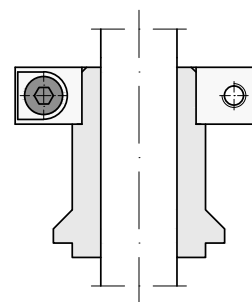

Clamping ring (CR)

FLANGE OF COOLING OR HEATING:

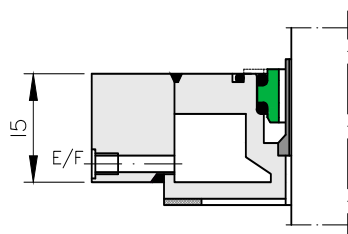

A: Cooling flange. It can also be used as a heating flange (Tmax= +350 °C)

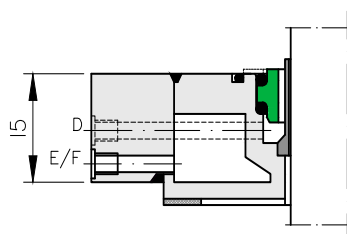

B: Leakage drain. It can also be used as a flush or as a heating flange.

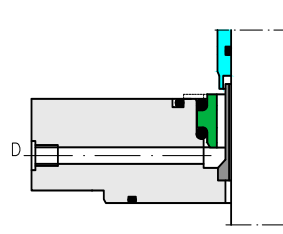

C: Leakage drain. It can also be used alternatively as a flush.

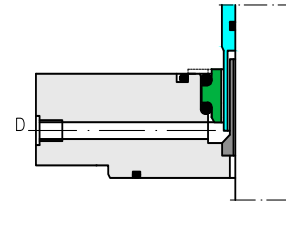

D: Polymerisation barrier. It can also be used alternatively as a leakage drain or a flush.



AUXILIARY PRODUCTS...

LCY

SECTORS:

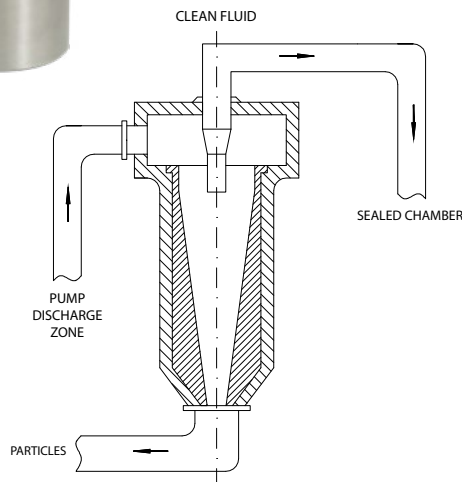

CHARACTERISTICS:

- Working pressure: 64 bar.
- Temperature: up to 125 °C .
- Materials: Stainless steel

DESCRIPTION:

Working fluids often contain sand particles, incrustated residue from boilers and pipes etc. which can damage the mechanical seal and reduce its durability. Situations of this type can be avoided by installing a cyclone.

This type of element is installed outside the pump, between the discharge zone and the mechanical seal chamber. A current or vortex of pressurised fluid is generated inside it and the effect of the centrifugal force separates the particles suspended in the fluid. The particles that are heavier than the fluid are thrown towards the walls and dragged to the lower part of the LC, while the clean fluid emerges from the top and is returned to the chamber where the mechanical seal is located.

API31 and API41 configuration.

These elements require no maintenance and do not become blocked over time.

LHP

SECTORS:



CHARACTERISTICS:

- Temperature: -30°C to +110 °C.
- Working pressure: 30 bar.
- Volume (L) : 2 l.
- Flow rate : 15 ml / run-out
- Materials: Stainless steel / polyethylene.

DESCRIPTION:

LHP with a built-in tank for placing on the reservoir. Installed directly in the LTS reservoir.

LST8

SECTORS:

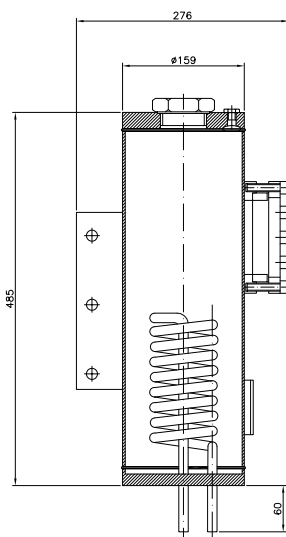

CHARACTERISTICS:

- Temperature: -60° C to +200° C.
- Working pressure: up to 16 bar.
- Volume: 8 l.
- Materials: AISI304.

DESCRIPTION:

LST8 for supplying barrier fluid with or without pressure in double cartridge or mechanical seal.

It includes a cooling coil to regulate the temperature of the barrier fluid.

Installations which enables the circulation of the barrier fluid due to the thermosyphon effect or the pumping ring (mechanical seal). API52, API53 and API53A configuration.

It may be supplied with instruments for automatic level, pressure and temperature control.

LST9

SECTORS:

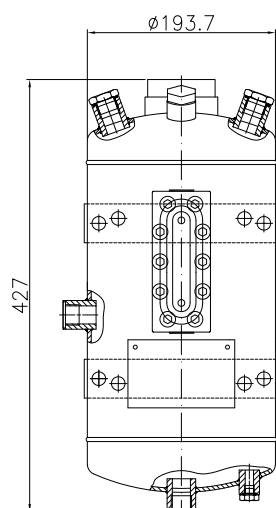

CHARACTERISTICS:

- Temperature: -60°C to +200 °C.
- Working pressure: up to 25 bar.
- Volume: 9L
- Materials: Stainless steel.

DESCRIPTION:

LST9 for supplying barrier fluid with or without pressure in double cartridge or mechanical seal installations which enables the circulation of the barrier fluid due to the thermosyphon effect or the pumping ring (mechanical seal). API52, API53 and API53A configuration.

It may be supplied with instruments for automatic level, pressure and temperature control and verification and a cooling coil to regulate the fluid barrier temperature.

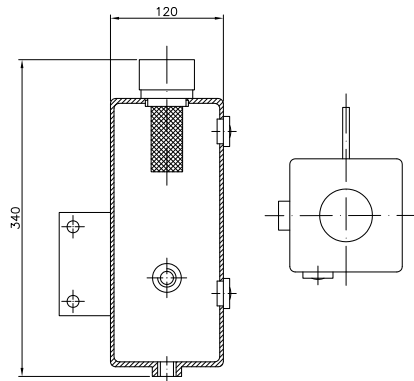

CHARACTERISTICS:

- Temperature: -30°C up to +200 °C.
- Working pressure : no pressure
- Volume (L) : 3.2 l.
- Materials: Stainless steel / polyethylene.

DESCRIPTION:

LQT for supplying fluid in installing mechanical seals with a quenching or tandem system. The fluid movement is the result of the thermosyphon effect or the pumping ring (mechanical seal). API51 and API52 configuration (no pressure).

Kitting

We supply spare parts for all our cartridges and can adapt to different combinations of materials for the contact surfaces and O-rings, springs, gaskets etc. and can make faster and more flexible deliveries. All our operations are guaranteed by static operating tests after manipulation.

Faces for cartridges and seals with detachable surfaces:

- Silicon carbide.
- Tungsten carbide.
- Impregnated carbon.

Metal plugs
1/8", 1/4" NPT and 3/8"NPT.

O-rings
High-performance materials
-Aflas®, FFKM.
Certified materials
-FDA, CE 1935/2004, KTW.

Self-centering
Setting clips.

Springs for cartridges and multispring seals:

- AISI 316 steel (G).
- Hastelloy® C.

Drive screws and set screws

Flange gaskets

- Basic.
- Special materials Frenzelit range.
- Elastomer materials.
- PTFE.

Production center - Quality control

Production center

Lidering's modern, adequate equipment enables it to execute repair and transformation operations on mechanical seals and cartridges.

The process commences by diagnosing the condition of the part, and after this, we execute the necessary processes for cleaning, polishing and lapping the contact surfaces, grinding parts and replacing components, etc.

After carrying out these operations, the sealing of the repaired parts is checked by pressure test, to ensure that the part is ready for operation in any application that requires sealing of the highest standard.

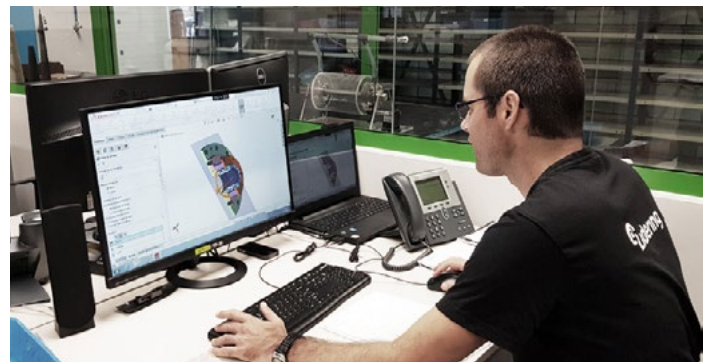

We also offer additional services such as a diagnostic report on the sample received and a detailed analysis of the faults observed or laser marking of parts to facilitate their identification and traceability.

Quality control, checking and testing

All the mechanical seals manufactured or repaired by Lidering are subject to the strictest quality controls. We guarantee their operation in the most demanding applications.

Furthermore, if the customer wishes, we can provide other services such as sealing controls in static or dynamic conditions and at different pressures before delivering the product. Working along this line we perform static sealing controls on all our cartridges before delivering them to the customer.

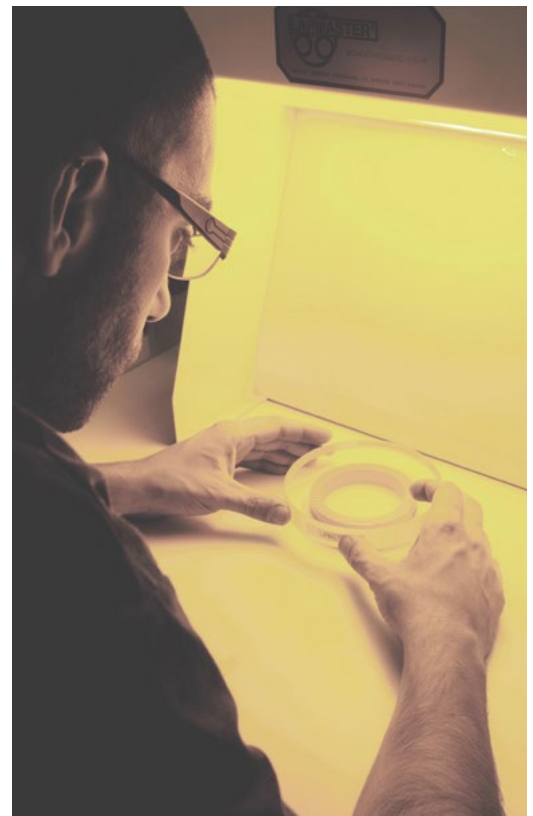

Compatibility Chart

LIDERING	BURGMANN	CHESTERTON
SINGLE CARTRIDGE		
LSC10	-	-
LSC10B-FQ	H75VN	-
LSC25	UNITEX	-
LSC38-FQ	MTEX-QNM/TNM	153
LSC40	CARTEX-SNO	-
LSC40-F	CARTEX-SN	150
LSC40-FAS	CARTEX ANSI STANDARD BORE ASPN	-
LSC40-FAB	CARTEX ANSI BIG BORE ABPN	-
LSC40-FABQ	CARTEX-ABTN/ABQN	-
LSC40-FASQ	CARTEX-ASTN/ASQN	-
LSC40-FQO	CARTEX-QN/TN /QE	-
LSC40-FQG	CARTEX-QN/TN	-
LSC40-FQOAB	CARTEX-QN/TN ANSI BIG BORE	-
LSC40-F QOAS	CARTEX-QN/TN ANSI STANDARD BORE	-
LSC40-FQGAB	CARTEX-QN/TN ANSI BIG BORE	-
LSC40-FQGAS	CARTEX-QN/TN ANSI STANDARD BORE	-
LSC50-F	SPLITEX	442
LSC80	M481KL	-
LSC85	-	-
LSC90	-	-
LSC211A-F	UNITEX	155
DOUBLE CARTRIDGE		
LDC21	CARTEX-DN	255
LDC38	-	-
LDC39-D	-	-
LDC40	CARTEX-DN	255
LDC40-AB	CARTEX DUAL ANSI BIG BORE	-
LDC40-AS	CARTEX DUAL ANSI STANDARD BORE	-
LDC80	M451 M481KD	-
LDC90	-	-
MULTISPRING SEALS		
LMS26	-	-
LMS27	SECCOMIX	-
LMS28	-	-
ACCESSORIES		
LST	TS2000	-
LCY	ZY	-
LHP	-	-
LQT	QTF	-

AESEAL	FLOWERVE	CRANE	ROTEN
-	-	-	-
-	-	-	-
-	ISC1BX	5615	-
SMSS / CSSN	-	-	-
SMSS / CSSN	ISC1PX	-	902
-	-	-	-
-	-	-	-
-	-	-	-
-	-	-	-
CURC/CRCO	-	4610/5610	-
CURC/CRCO	-	4610/5610	-
-	-	-	-
-	-	-	-
-	-	-	-
RDS	PSII	3710	-
-	-	-	-
-	-	-	-
-	-	SAFEMATIC JSC1	-
CONVERTOR II	-	-	942
DMSF	ISC2PP	4620 / 5620	922
	ISC2BB	5625	-
	-	5620	-
DMSF	ISC2PP	4620 / 5620	922
-	-	-	-
-	-	-	-
-	-	-	-
-	-	SAFEMATIC SE2	-
-	-	-	-
-	VRA	-	-
-	-	32	-
-	-	-	-
-	-	-	-
-	-	-	-

SINGLE SEALING PLANS

SINGLE FLUIDS, Lubrication

Various parameters exist that determine the durability of a mechanical seal. Temperature, pressure, speed, fluid type (sticky, laden with particles, etc.) which all have a decisive effect on wear and damage of the mechanical seal materials.

To reduce these effects and improve the seal durability, API plans can be used. Below are some of the ones applicable to our products.

PLAN	DESCRIPTION	OBJETIVE	APLICATIONS
PLAN 01	Fluid recirculation from the pump discharge. This is applied as a flushing/washing operation on the seal chamber.	To ensure the lubrication of the seal and reduce the temperature in the seal chamber.	In general for clean fluids that do not polymerise at moderate temperatures. Particle-laden fluids may block the flushing/washing connection.

PLAN	DESCRIPTION	OBJETIVE	APLICATIONS
PLAN 11	Circulation of the fluid from the pump discharge to the seal chamber, passing through a flow rate controller.	To ensure the lubrication of the seal and control the temperature.	In general for clean fluids that do not polymerise at moderate temperatures.

PLAN	DESCRIPTION	OBJETIVE	APLICATIONS
PLAN 12	Circulation of the fluids from the discharge to the seal chamber, passing through a filter/cyclone and through a flow rate controller.	To ensure the lubrication of the seal and prevent the mechanical seal from abrasion by particles.	Clean liquids which may contain particles. The filters may become blocked and so it is best to use cyclones in the presence of solids.

PLAN	DESCRIPTION	OBJETIVE	APLICATIONS
PLAN 13	Circulation from the seal chamber to the suction area, passing through a flow rate controller.	To guarantee the fluid circulation. To ventilate the seal cavity in vertical pumps. To reduce the seal cavity pressure.	Vertical pumps. Clean fluids in vertical pumps.

PLAN	DESCRIPTION	OBJETIVE	APLICATIONS
PLAN 14	Circulation from the pump discharge zone to the seal chamber, passing through a flow rate controller and from the seal chamber to the suction area.	To ventilate the seal cavity in vertical pumps. -To control the temperature. To provide the appropriate pressure in the seal chamber, thereby preventing fluid vaporisation.	vertical pumps.

DRAWING

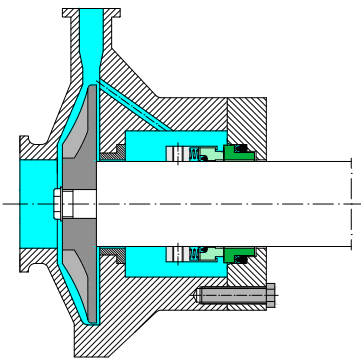

PLAN 01

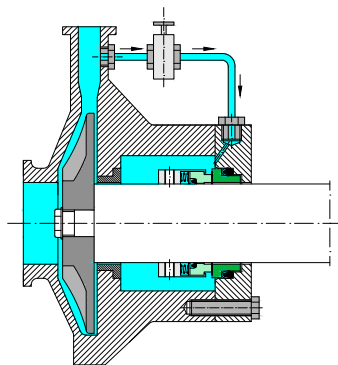

PLAN 11

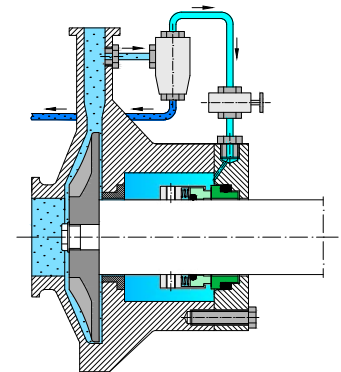

PLAN 12

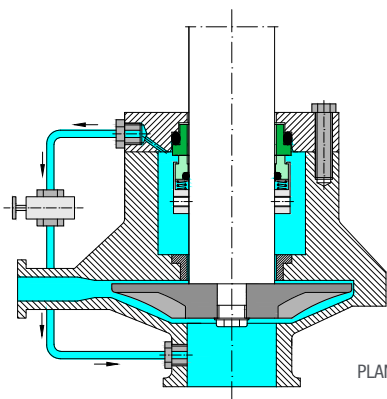

PLAN 13

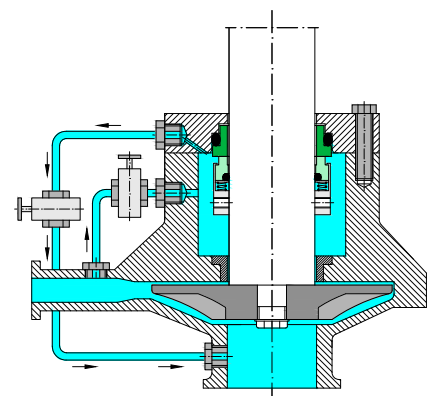

PLAN 14

SINGLE SEALING PLANS

HOT FLUIDS, COOLING

Fluids at high temperatures tend to evaporate when they reach the seal contact surfaces, provoking a lack of lubrication that causes damage to the seal. To reduce these effects the following API plans can be applied:

PLAN	DESCRIPTION	OBJETIVE	APLICATIONS
PLAN 02	Closed chamber, with no external fluid circulation. Cooling or heating chamber. There is no direct flow entry or exit in the seal chamber.	To reduce or increase the seal chamber temperature, depending on the nature of the fluid.	Horizontal pumps (not recommended in vertical pumps). For fluids that solidify when the temperature is reduced or to control high fluids temperatures.

PLAN	DESCRIPTION	OBJETIVE	APLICATIONS
PLAN 21	Circulation of pumped fluids from the discharge to the seal chamber, passing through a flow rate controller and a heat exchanger.	To control the fluid temperature in the seal chamber. This prevents the vaporisation of the fluid between the seal faces.	Horizontal pumps. Clean fluids at high temperatures. Sticky products may block the connections and pipes. In such cases, use Plan 23.

PLAN	DESCRIPTION	OBJETIVE	APLICATIONS
PLAN 22	Circulation of pumped fluids from the discharge to the seal chamber, passing through a flow rate controller, a filter/cyclone and a heat exchanger.	To control the seal chamber temperature and prevent the mechanical seal from abrasion by particles.	Horizontal pumps. Clean fluids at high temperatures that may be laden with particles.

PLAN	DESCRIPTION	OBJETIVE	APLICACIONES
PLAN 23	Circulation of pumped fluids from the discharge to the seal flush connection, passing through a flow rate controller and a heat exchanger.	To control the fluid temperature in the seal chamber. This prevents the vaporisation of the fluid between the seal faces.	Horizontal or vertical pumps. Clean fluids at high temperatures. Hot water, boiler food products. Hot oils.

DRAWING

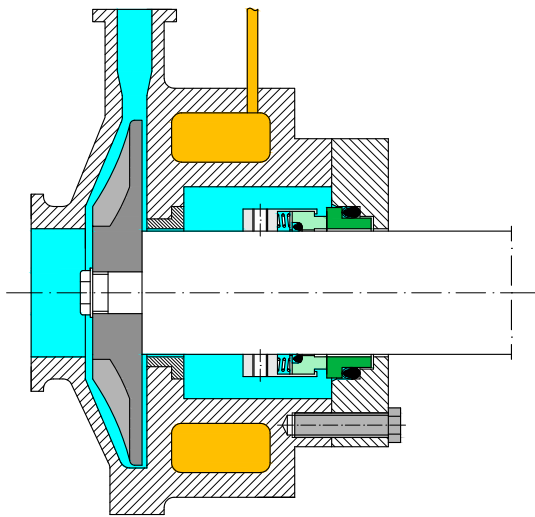

PLAN 02

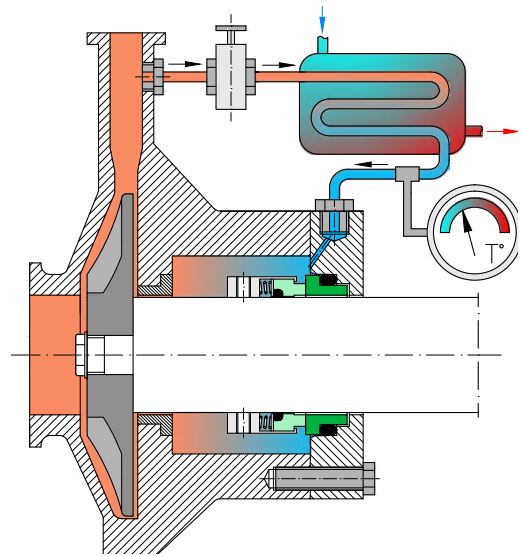

PLAN 21

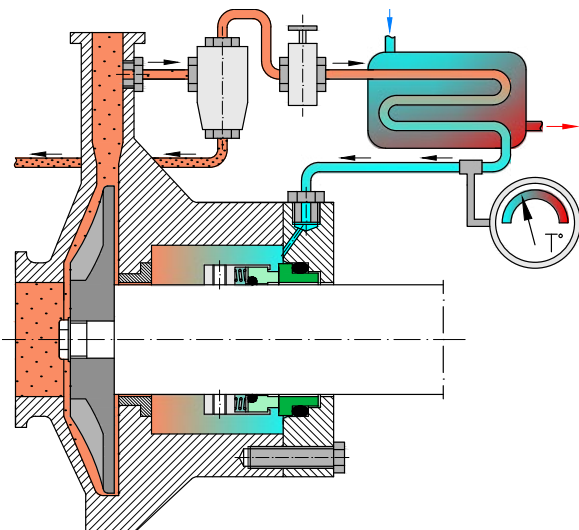

PLAN 22

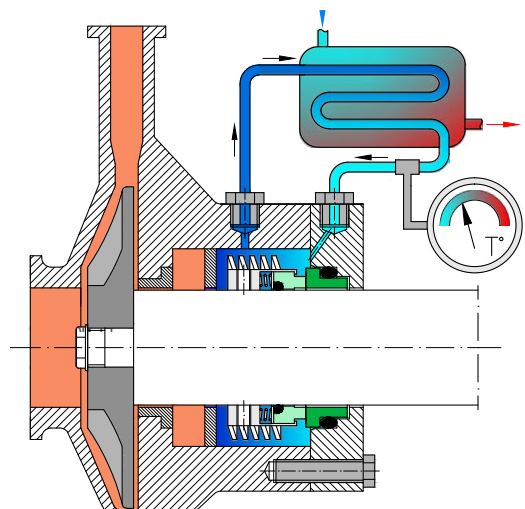

PLAN 23

SINGLE SEALING PLANS

ABRASIVE FLUIDS OR FLUIDS WITH SUSPENDED SOLIDS

Fluids laden with particles that accelerate wear in mechanical seal materials. To reduce this effect the following API plans can be applied:

PLAN	DESCRIPTION	OBJETIVE	APLICATIONS
PLAN 31	Circulation of the pumped fluid from the pump discharge to the seal chamber, passing through a cyclone. Fluids with solids are returned to the suction area.	To prevent the abrasion of the mechanical seal by particles.	Horizontal or vertical pumps. Fluids with suspended solids whose specific gravity is twice that of the fluid. In vertical pumps, a shaft bushing must be included at the base of the compartment.

PLAN	DESCRIPTION	OBJETIVE	APLICATIONS
PLAN 32	External injection of clean fluid to the mechanical seal chamber. The fluid must have a pressure 2 bar higher than that of the seal chamber and be compatible with the pumped product.	To reduce the heat in the seal chamber. To eliminate deposits from the chamber. To increase the margin between the seal chamber pressure and the fluid vapour pressure. To reduce the formation of air bubbles between the seal faces.	Horizontal or vertical pumps. Dirty, contaminated fluids or fluids that could crystallise on the air side of the seal when there is a leak. Environments with little lubricating properties.

PLAN	DESCRIPTION	OBJETIVE	APLICATIONS
PLAN 41	Circulation of the pumped fluid from the pump discharge to the seal chamber, passing through a cyclone and sending the clean fluid to a heat exchanger. There must be a difference in pressure between the pump discharge and suction area (at least 1 bar and no more than 11 bar).	To control the seal chamber temperature and improve the mechanical seal lubrication.	Horizontal or vertical pumps. Fluids with suspended solids whose specific gravity is twice that of the fluid.

DRAWING

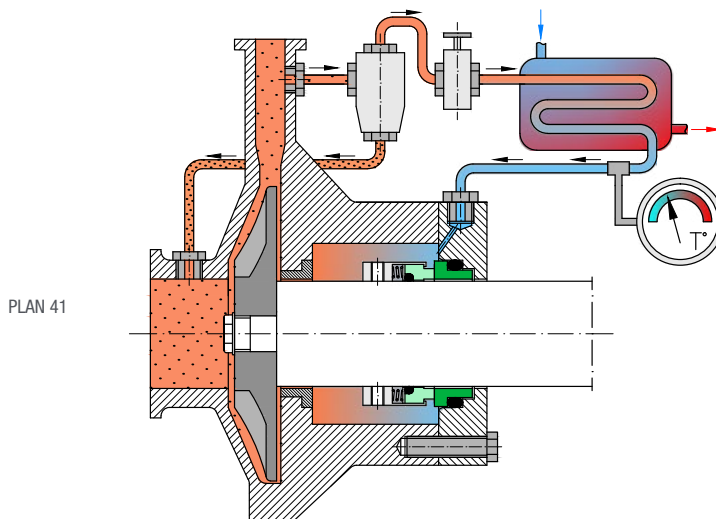
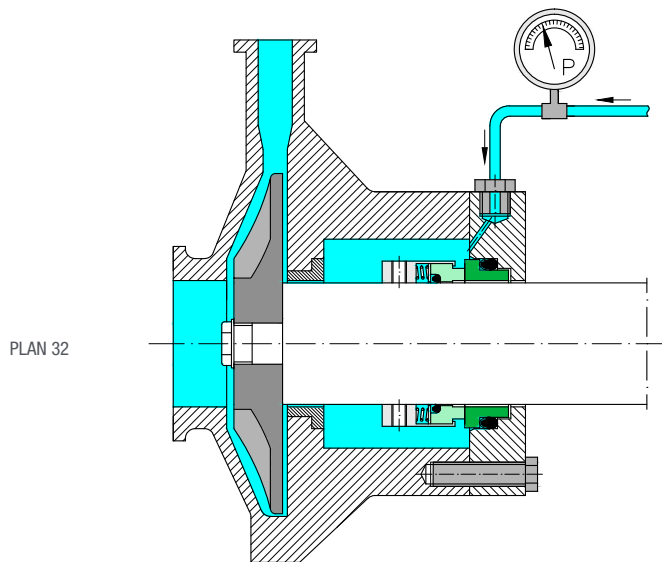
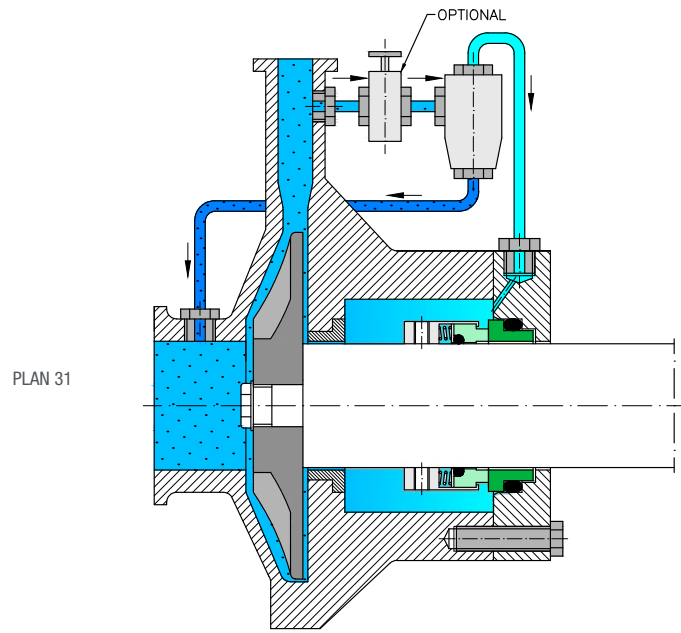

SINGLE AND DOUBLE SEALING PLANS

DAINGEROUS FLUIDS

Dangerous fluids are those which, because of their characteristics, may cause harm to elements and/or people in the event of a leak.

PLAN	DESCRIPTION	OBJETIVE	APLICATIONS
PLAN 51	Static column of non-pressurised fluid inside a tank, through the quench connection.	To prevent potential leaks from being emitted into the atmosphere.	Horizontal or vertical pumps. Fluids that crystallise when in contact with the atmosphere. Dangerous fluids with low concentrations.

PLAN	DESCRIPTION	OBJETIVE	APLICATIONS
PLAN 52	Forced circulation of an external non-pressurised fluid used as a barrier fluid. This fluid is circulated through a pumping ring due to the thermo-siphon effect.	To prevent atmospheric contamination in the event of leaks, using the external seal (atmospheric side) as a safety seal. Zero or very low emissions.	Horizontal or vertical pumps. Non-pressurised, double seal layout (tandem). Fluids that crystallise or vaporise when in contact with the atmosphere. Dangerous fluids with low concentrations, explosive or flammable fluids.

PLAN	DESCRIPTION	OBJETIVE	APLICATIONS
PLAN 54	Injection of a pressurised barrier fluid from an external source (pressure of 2 bar above the seal chamber).	To prevent atmospheric contamination in the event of leaks, using the external seal (atmospheric side) as a safety seal. Zero or very low emissions.	Horizontal or vertical pumps. Pressurised double seal layout at a high pressure. Fluids that crystallise or vaporise when in contact with the atmosphere. Dangerous fluids with high concentrations. Explosive or flammable fluids.

DRAWING

PLAN 51

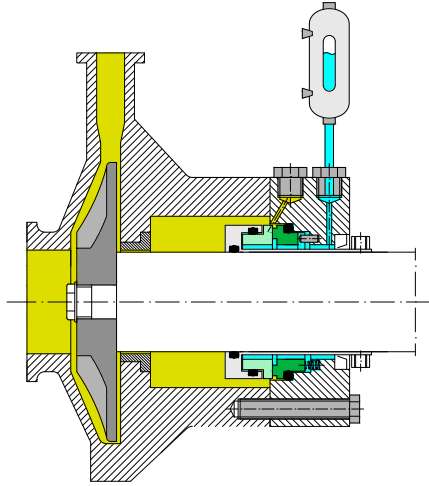

PLAN 52

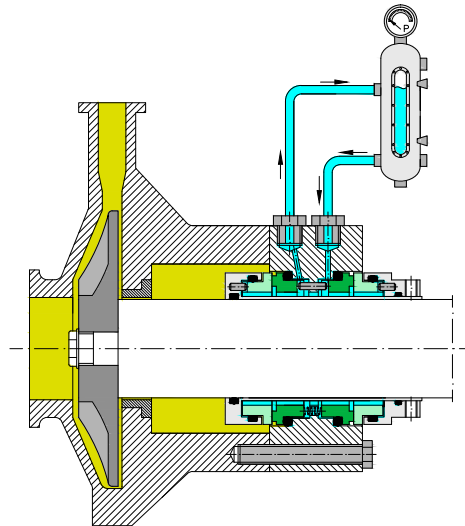

PLAN 54

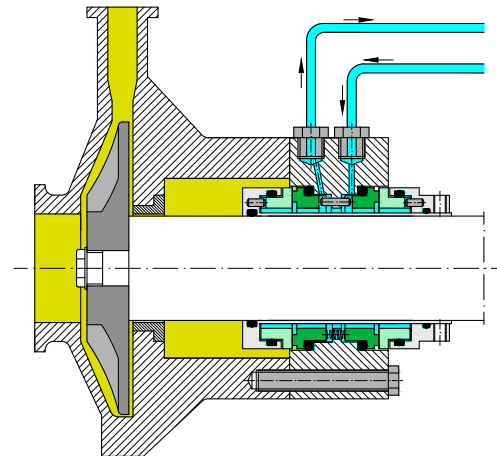

DOUBLE SEALING PLANS

DANGEROUS FLUIDS

Dangerous fluids are those which, because of their characteristics, may cause harm to elements and/or people in the event of a leak. API plans can be used to reduce such risks:

PLAN	DESCRIPTION	OBJETIVE	APLICATIONS
PLAN 53 A	Forced circulation through a pumping ring of a barrier fluid in a pressurised tank with a pressure that is 2 bar higher than the product fluid.	To prevent atmospheric contamination in the event of leaks, using the external seal (atmospheric side) as a safety seal. Zero or very low emissions.	Horizontal or vertical pumps. Fluids that crystallise or vaporise when in contact with the atmosphere. Dangerous fluids with high concentrations, explosive or flammable fluids.
PLAN 53 B	Forced circulation through a pumping ring of a barrier fluid in a closed pressurised circuit. A storage tank provides and maintains the pressure in the circulation system. The heat is eliminated through a heat exchanger.	To prevent atmospheric contamination in the event of leaks, using the external seal (atmospheric side) as a safety seal. Zero or very low emissions, maintaining a constant pressure difference with respect to the process. Same as Plan 53A. It prevents the entry of pressurised gas. It provides additional cooling, by air or water, depending on the heat load.	Horizontal or vertical pumps. Double pressurised seal layout (back to back or face to face). The barrier fluid must be 2 bar above the product fluid. Fluids that crystallise or vaporise when in contact with the atmosphere. Dangerous fluids with high concentrations, explosive or flammable fluids.
PLAN 53 C	Forced circulation through a pumping ring of a barrier fluid in a closed pressurised circuit. A piston storage tank provides and adjusts the pressure in the circulation system, comparing it with the seal cavity pressure. The heat is eliminated through a heat exchanger, cooled by air or water.	To prevent atmospheric contamination in the event of leaks, using the external seal (atmospheric side) as a safety seal. Zero or very low emissions.	Horizontal or vertical pumps. Installation of pressurised double seals (back to back or face to face) with a variable barrier pressure greater than 10 bar. Fluids that crystallise or vaporise when in contact with the atmosphere. Dangerous fluids with low concentrations. Explosive or flammable fluids. The same as with Plan 53A, but for higher pressures, preventing reverse pressures and providing additional seal stability.

DRAWING

PLAN 53A

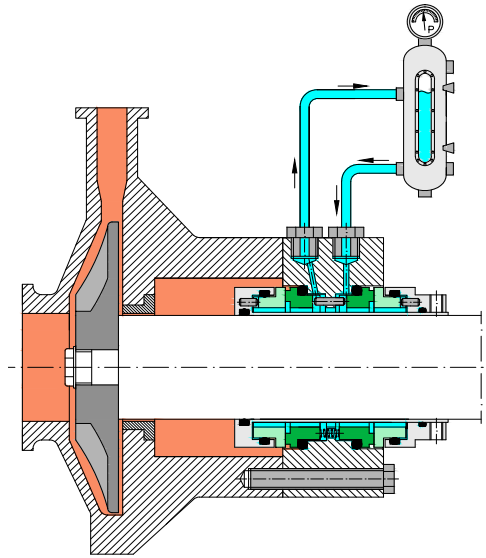

PLAN 53B

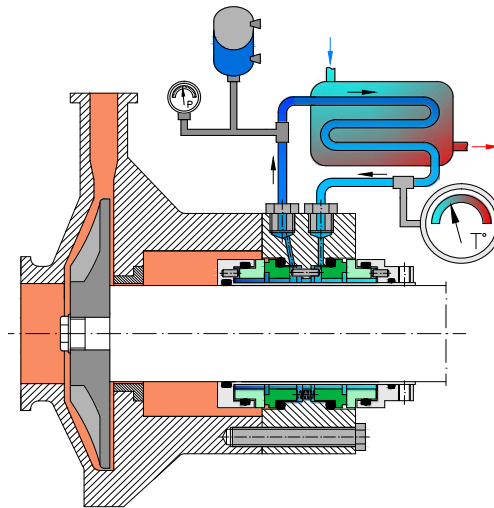

PLAN 53C

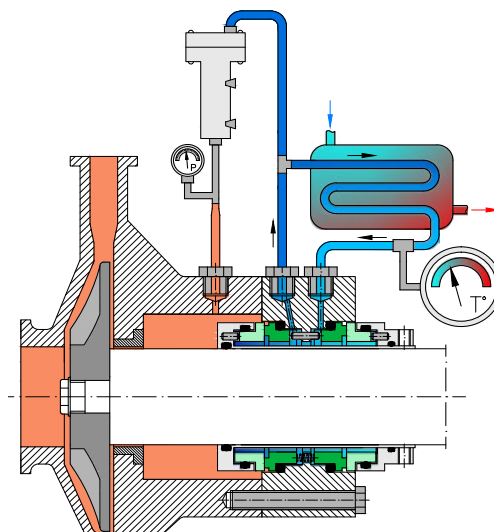

SINGLE SEALING PLANS

FLUIDS IN GENERAL

The following API plans are used in conjunction with other plans.

PLAN	DESCRIPTION	OBJETIVE	APLICATIONS
PLAN 61	Blocked vent and drainage connections, for use as needed.	To ensure that these connections are available in the event of need and also to prevent particles passing through to the seal chamber.	Horizontal or vertical pumps. Single seal layout.

PLAN	DESCRIPTION	OBJETIVE	APLICATIONS
PLAN 62	Injection of an external fluid to be used for quenching and flushing/washing. The quench lubricates the seal contact surfaces on the air side, with vapour or water. The flushing/washing operation has a lubricating function.	To guarantee seal lubrication, reducing the formation of particles between the contact surfaces due to carbonisation, oxidation or crystallisation.	Horizontal or vertical pumps. Single seal layout. Fluids that crystallise when in contact with the atmosphere or generate solid deposit that block or stick to the seal faces.

PLAN	DESCRIPTION	OBJETIVE	APLICATIONS
PLAN 65	Leak collector plan for single seals, used for the automatic detection of leaks through a level switch that triggers an alarm when a leak occurs. It has a bypass around the opening to prevent the build-up of pressure.	To have a safe system for controlling and detecting leaks, while also having a drainage system for them in fluids that may condensate.	Horizontal or vertical pumps. Single seal layout. Systems in which an excessive leak indication is required without the need for a physical inspection. Remote sites or sites that are difficult to access. Systems in which it is necessary to stop the equipment automatically in the event of a massive leak.

DRAWING

PLAN 61

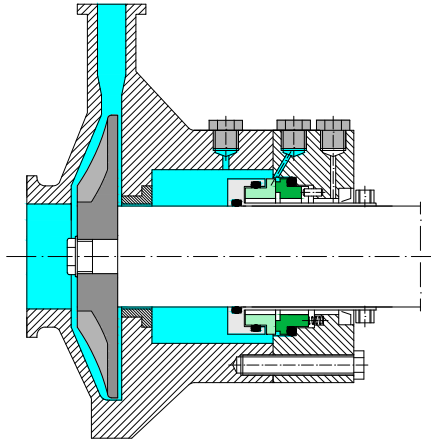

PLAN 62

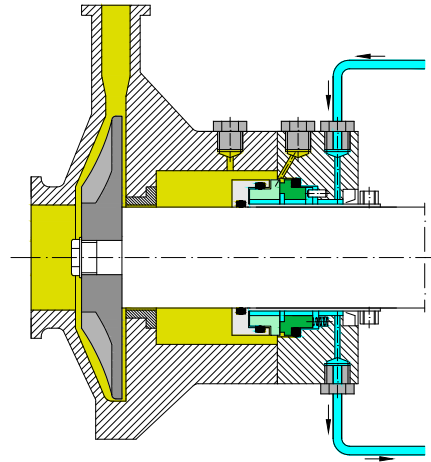

PLAN 65

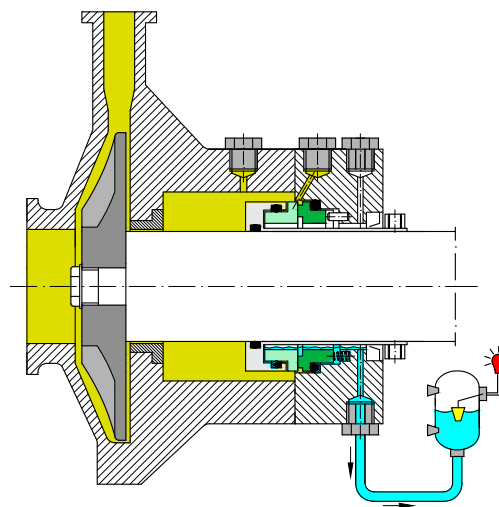

SUMMARY

FLUIDS IN GENERAL

The following API plans are used in conjunction with other plans.

PUMPED FLUID	ACTION REQUIRED	API PLANS
CLEAN FLUIDS	CIRCULATION (LUBRICATION)	PLAN 01 PLAN 11 PLAN 12 PLAN 13 PLAN 14
HOT FLUIDS	COOLING	PLAN 02 PLAN 21 PLAN 22 PLAN 23
ABRASIVE FLUIDS OR FLUIDS WITH SUSPENDED SOLIDS	LUBRICATION	PLAN 31 PLAN 32
ABRASIVE FLUIDS AT HIGH TEMPERATURES	COOLING AND LUBRICATION	PLAN 41
DANGEROUS FLUIDS	SAFETY	PLAN 51 PLAN 53 PLAN 52 PLAN 54
FLUIDS IN GENERAL	EMISSIONS CONTROL	PLAN 61 PLAN 62 PLAN 65

TYPE MECHANICAL SEALS	RECOMENDADED API PLANS
SINGLE MECHANICAL SEALS	01,02,11,12,13,14,21,22,23,31,32,41
DOUBLE MECHANICAL SEALS	52,53A,53B,53C,54
QUENCH MECHANICAL SEALS SEALS	51,61,62

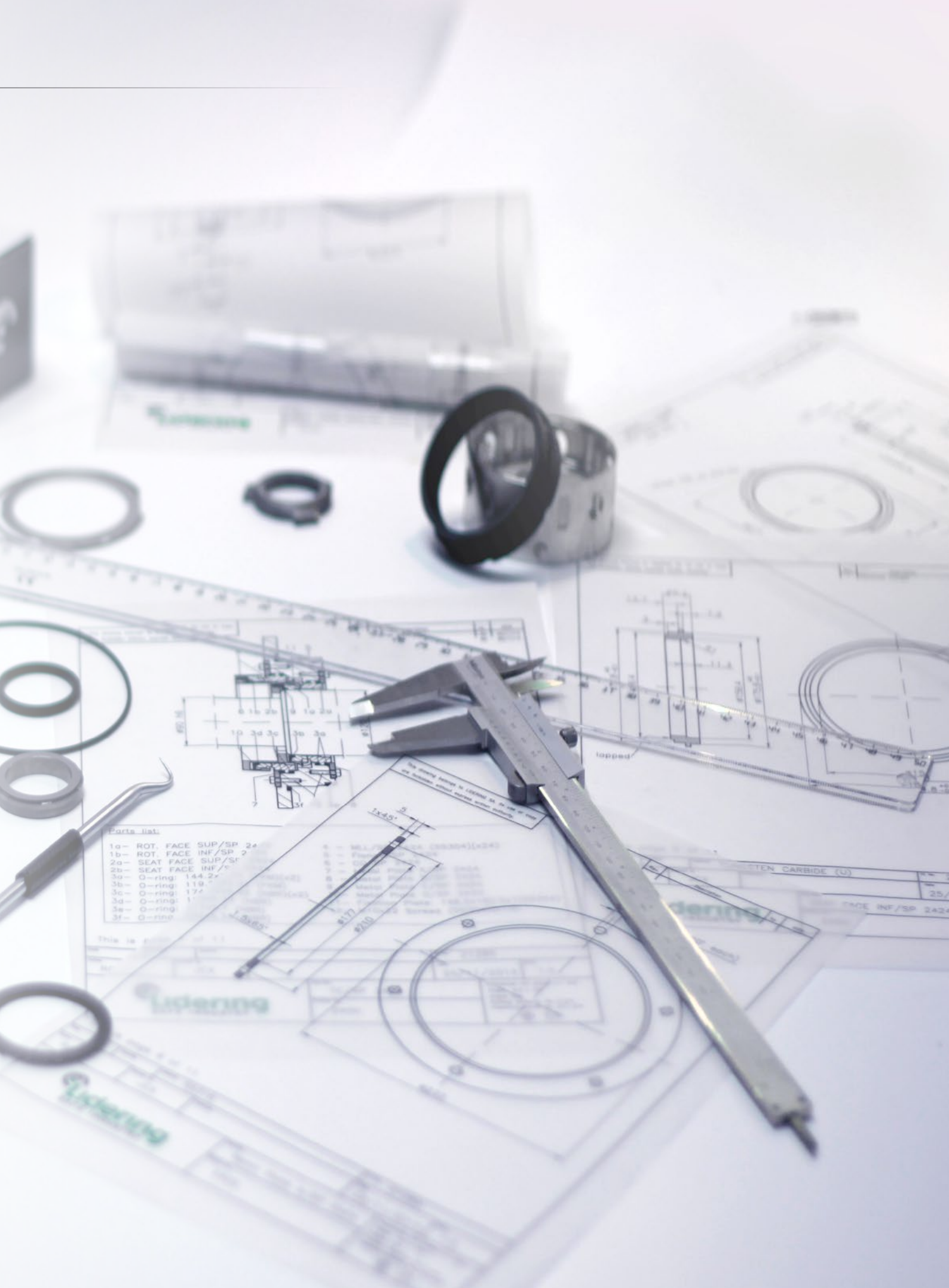

Parts list:

- 1a- ROT. FACE SUP/SP 2a
- 1b- ROT. FACE INF/SP 2
- 2a- SEAT FACE SUP/SP
- 2b- SEAT FACE INF/SP
- 3a- O-ring: 144.2x
- 3b- O-ring: 119.
- 3c- O-ring: 172.
- 3d- O-ring: 11.
- 3e- O-ring:
- 3f- O-ring:

Special designs

It is not always possible to use a conventional mechanical seal. Complex applications with special requirements and pumps with small housings need mechanical seals with non-standard profiles.

Our engineering centre designs and manufactures customised solutions adapted to the specific needs of our customers, in large or small production runs.

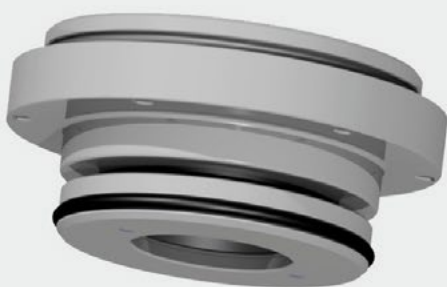
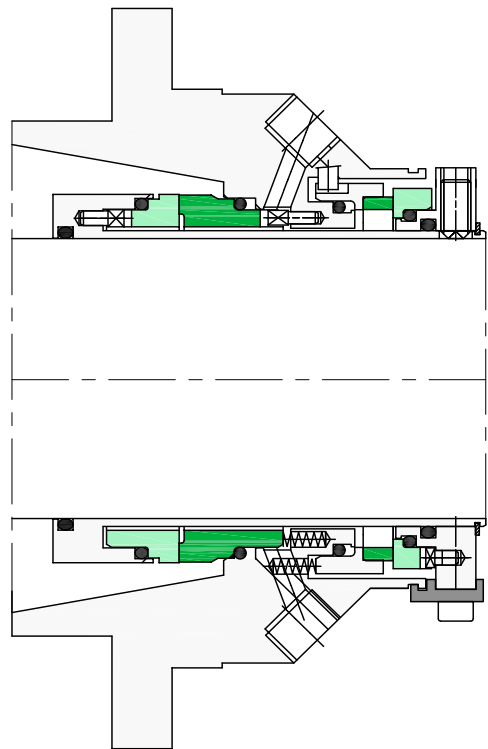
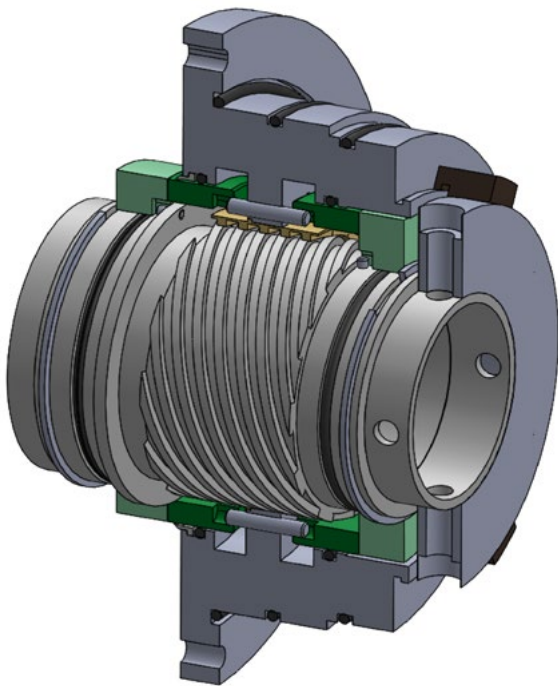

Specific models for agitators or reactors that work with simple mixtures, solid dissolutions or suspended fluids. In which gases or residual products may be released as a result of the chemical reactions generated inside the agitator. The double internal seal is permanently lubricated by the barrier fluid. This type of cartridge seal is often used in the food, pharmaceutical and chemical industries.

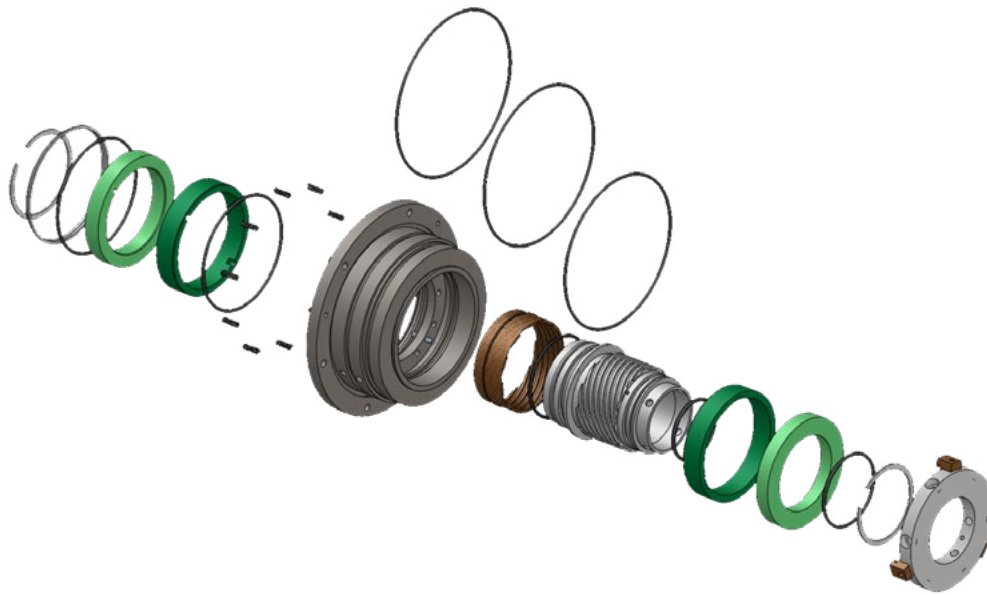

Contact surfaces (position I and II)

SYNTHETIC CARBONS

A:	Antimony-impregnated carbon
B:	Resin-impregnated carbon
B ₂ :	Resin-impregnated carbon
B ₃ :	Pure non-impregnated carbon
B ₄ :	Self-lubricating carbon
B ₅ :	Hot pressed carbon

METALS

E:	Chromium steel; AISI 420 (1.4021 ; 1.4028)
F ₁ :	Nickel-chromium steel; AISI 431 (1.4057)
G:	Nickel-chromium-molybdenum steel; AISI 316 (1.4401)
D:	Duplex stainless steel (1.4462 ; 1.4162)
Z:	Nickel-chromium-molybdenum steel with chrome oxide
Z ₂ :	Nickel-chromium-molybdenum steatite steel
C:	Brass
C ₂ :	Bronze

CARBIDES

U:	Tungsten carbide with welded / inserted nickel
U ₁ :	Solid tungsten carbide with nickel
Q ₁ :	Sintered silicon carbide with no free silicon
Q ₂ :	Sintered silicon carbide
Q ₅ :	Sintered silicon carbide with no free silicone diamond coating
Q ₆ :	Sintered silicon carbide with carbon

CERAMIC MATERIALS

V:	Alumina oxide 99,5%
V ₂ :	Alumina oxide 95%
X:	Steatite

SYNTHETIC MATERIALS

Y:	Glass-filled PTFE
Y ₁ :	PTFE-graphite

Synthetic carbons

Synthetic carbons are the materials most often used due to their intrinsic characteristics: they are self-lubricating, economical and have good chemical resistance. There are several types:

Code A: Antimony-impregnated carbon.

It has less chemical resistance than resin-impregnated carbon but is used due to its resistance to high temperatures (350°C). It is recommended for high pressure applications with hydrocarbons, thermal oils or gases.

Code B: Resin-impregnated carbon.

The most standard and economical. It can withstand temperatures of up to 180°C.

Code B₂: Resin-impregnated carbon.

A mechanised carbon with a more compact internal structure which gives it greater chemical resistance than type B graphite.

Code B₃: Non-impregnated carbon.

A carbon with no resin or metal content with a very high resistance to temperature (3000° C) and chemicals.

Secondary seals (position III)

ELASTOMERS

P:	Nitrile rubber (NBR)
H:	Hydrogenated nitrile (HNBR).
N:	Chloroprene rubber®(CR)
E:	Ethylene-propylene diene monomer (EPDM)
X:	Ethylene-propylene diene monomer peroxide (EPDMPX)
S:	Silicon rubber (MVQ)
V:	Fluorocarbon (FKM)
K:	Perfluorocarbon rubber (FFKM)
M:	Rubber coated with PTFE (FEP-FKM / FEP-MVQ)
A:	Tetrafluoro-ethylene Propylene Rubber (TFE/P or Aflas®)

NON-ELASTOMERS

G:	Graphite
T:	PTFE

Springs and other metal parts (position IV and V)

E:	Chromium steel; AISI 420 (1.4021; 1.4028)
F:	Nickel-chromium steel; AISI 304 (1.4301)
F ₁ :	Nickel-chromium steel; AISI 431 (1.4057)
G:	Nickel-chromium-molybdenum steel; AISI 316 (1.4401)
G ₂ :	AM350 nickel-chromium-molybdenum steel. AM350
G ₃ :	AISI 904L (1.4539)
G ₄ :	316Ti (1.4571)
L:	Nickel-chromium-molybdenum steel; AISI 316L (1.4404)
L ₂ :	Nickel-chromium-molybdenum steel; AISI 316L (1.4435)
D:	Nickel-chromium-molybdenum duplex stainless steel (1.4462)
D ₂ :	Super Duplex (1.4410)
M:	Hastelloy® C4
M ₂ :	Inconel® 718 (2.4668)
M ₃ :	Alloy® 20 (2.4668)
M ₄ :	Monel®400
M ₅ :	Hastelloy® C276 (2.4819)
B:	Brass
R:	AISI 316 + PTFE coverage

Ceramic materials

Ceramic materials have extremely high purity, are very resistant to wear and have high chemical resistance. However, they become fragile in the presence of sudden changes in temperature (thermal shock).

• Code X: Stéatite.

Its composition is silica oxide (SiO₂) 52%, magnesium oxide (MgO) 23%, alumina oxide (Al₂O₃) 5.1%. It is ochre in colour and used in clean water applications. An economical material. Has low chemical resistance and low thermal conductivity, for which reason it does not dissipate heat well. Low resistance to thermal shock.

• Code V: Alumina oxide with a purity of 99.5%.

It is chemically inert and has excellent resistance to wear. Due to its purity, it can withstand a higher degree of thermal shock than other types of ceramic. It is recommended in clean water operations, in combination with graphite (B).

Low thermal conductivity and poor heat dissipation. Low resistance to thermal shock.

Metal carbides

Metal carbides are extremely hard materials manufactured by sintering. They have high chemical and wear resistance and are used in environments with solids or particles which can attack soft materials such as carbon.

- **Code U: Inserted / welded tungsten carbide.**

An extremely hard and tenacious material. It is appropriate for applications with a pH of more than 6 (in the case of welded parts). Good behaviour with respect to wear under severe conditions. Good thermal conductivity. High elastic modulus, meaning it is not likely to become deformed, especially in high pressure applications. Limited chemical resistance, especially to acid products. A very high density material, which can be critical in high speed rotating operations. Limited capacity to withstand dry operation conditions or extremely limited lubrication conditions, especially when working with the same material.

- **Code Q: Silicon carbide.**

Good resistance to wear and to friction in heavy duty work. It is the perfect material for working in contact with abrasive and corrosive fluids, and at high pressures. Its main characteristics are as follows:

- High thermal conductivity, comparable to tungsten carbide.
- Low resistance to thermal shock.
- High elasticity modulus.
- Good chemical resistance.
- Lower density than tungsten carbide.

May be subject to chemical attack by certain strong alkaline products. For that reason it is important to choose the most appropriate silicon carbide grade:

Q₁: Contains no free silicon. It has the best chemical resistance of all carbides, but low tenacity. Its friction characteristics are poorer than grade Q₂, but higher than those of tungsten carbide.

Q₂: Contains free silicon. It has the best friction characteristics of all silicon carbides. Some acid or alkaline substances may cause lixiviation in free silicon but in general, it is more inert than tungsten carbide.

Q₆: Has a silicon and graphite carbide base. This mixture combines the high resistance to wear of silicon carbide and the lubricant properties of graphite.

Silicon carbide normally runs against resin-impregnated graphite (B), but metal carbons may also be used for high performance (hot water applications).

- **Code U₁: Solid tungsten carbide with nickel.**

An extremely hard and tenacious material. Limited chemical resistance, especially to acid products. Suitable for applications with pH values above 2. Good behaviour with respect to wear under severe conditions. Good thermal conductivity. High elastic modulus, meaning it is not likely to become deformed in comparison with metal materials. A very high density material, which can be critical in high speed rotating operations.

Limited capacity to withstand dry operation conditions or extremely limited lubrication conditions, especially when working with the same material.

The silicon carbide and carbon combination is frequently used, providing long life in a wide range of conditions due to its excellent resistance to thermal shock.

In applications with abrasives, it is advisable to use silicon carbide against tungsten carbide, which is the most effective combination due to its resistance to wear and friction.

Silicon carbide may work against itself in very abrasive conditions but the friction characteristics are not as good as silicon carbide against tungsten carbide.

When silicon carbide is used against itself, the best results are obtained using different types, for instance Q₁ against Q₂ or Q₂ against Q₆.

When hard material is worked against hard, the limited conditions of the application may give rise to sudden changes in surface temperature and dry operation. Although this occurs with a short space of time, it is best to use silicon carbide with graphite-impregnated silicon carbide (Q₆). Due to its graphite content, this combination is resistant to the absence of lubrication for a limited time.

Metals

- **Code E: AISI 420 chromium steel.**

This is tempered stainless steel with a surface hardness of less than 50 HRc. It is used with fluids such as water or oils.

- **Code F: Nickel-chromium steel AISI 304.**

Stainless steel used to manufacture springs and auxiliary parts.

- **Code F₁: Nickel-chromium steel.**

Stainless steel with good chemical resistance, used for fluids such as water, oils, chemicals, etc.

- **Code G: AISI 316 nickel-chromium-molybdenum steel.**

Stainless steel with very good chemical resistance used with water, oils, hydrocarbons and chemicals.

- **Code G₂: AM350 nickel-chromium-molybdenum steel.**

Specifically for metal bellows that must work at high temperatures up to +300°C.

- **Code L: Nickel-chromium-molybdenum steel; AISI 316L.**

Stainless steel with excellent chemical resistance. It provides a homogeneous surface with no pores and is recommended for hygienic applications.

- **Code Z: Nickel-chromium-molybdenum steel with chrome oxide.**

It is a coating of Chromium Oxide deposited on the steel by means of plasma. The hardness is superior to that of stellite steel.

- **Code Z₂: Nickel-chromium-molybdenum stellite steel.**

To obtain it, the steel surface is treated with plasma, leaving a thickness of 0.2 to 0.3 mm. with considerable surface hardness and increased resistance to wear.

Materials Codes (EN 12756)

- **Code D:**

Nickel-molybdenum duplex stainless steel, used for highly corrosive environments: marine, industrial, etc.

- **Code M: Hastelloy® C4**

A nickel, chromium and molybdenum alloy with great mechanical resistance and excellent chemical resistance for general use. It is used to make springs or auxiliary parts.

- **Code M₂: Inconel®718 (2.4668)**

A nickel (53%), chromium (18%), tantalum-niobium (5%) and molybdenum (3%) alloy. Good resistance to corrosion and excellent resistance to extreme temperatures, both high (600°C) and low (-250°C).

- **Code M₄: Monel®400.**

A nickel (63%) and copper (23%) alloy. High resistance to corrosion in saline, caustic and acid environments (hydrochloric acid, hydrofluoric acid, sulphuric acid) and at high and low temperatures. Good mechanical properties. Due to its copper content, it has low resistance to nitric acid and ammonia. Very often used in the naval sector.

Synthetic or plastic materials

These materials are widely recommended for cases in which carbon lacks the adequate chemical resistance. They are manufactured with a PTFE base mixed with different additives and have very high chemical resistance. They withstand temperatures of up to +240°C. Their use is limited to low pressures and speeds (PV factor).

- **Code Y:** Glass-filled

- **Code Y₁:** Graphite-filled PTFE

Secondary seals

- **Code P: Nitrile butadiene rubber NBR.**

For working with water, oil, grease, etc. Temperature resistance from -30°C to +100°C.

- **Code H: Hydrogenated NBR.**

Excellent resistance to lubricants and products refrigerants at temperatures of up to +150°C.

- **Code N: Chlorobutadiene rubber Neoprene® or CR.**

For fluids such as refrigerants, ozone, glycols, etc. Temperature resistance of from -40°C to +100°C.

- **Code E: Ethylene-propylene diene monomer EPDM.**

Good behaviour in the presence of hot water, steam, acetone, alcohol, etc. Temperature resistance from -40°C to +120°C.

- **Code X: Ethylene-propylene rubberhardened with peroxide (EPDMPX).** Good behaviour in the presence of hot water, steam, acetone, alcohol, etc. In contact with steam up to +130°C in continuous operation and peaks of +150°C.

- **Code S: Methyl-vinyl silicon rubber MVQ.**

Indicated for applications at low temperatures from -60°C to +200°C.

- **Code V: Fluorocarbon (FKM)**

High chemical and temperature resistance. Withstands temperatures of -15°C to +200°C except in hot water applications, in which case the temperature should not exceed 120°C.

- **Code K: Perfluorelastomer rubber FFKM.**

Excellent chemical resistance to a wide range of working fluids. Withstands temperatures ranging from -30 to +250 or +320°C depending on the type.

- **Code M: FEP encapsulated seals.**

Their chemical resistance is similar to that of PTFE. They are suitable for working at high temperatures ranging from -15°C to +200°C. Their main problem is the plastic behaviour of their surface, which makes them difficult to assemble in closed housings and they have a greater risk of being damaged.

- **Code A: Tetrafluoroethylene rubber, Aflas® or TPE/P.**

A material with high chemical resistance to most products and suitable for working with steam at temperatures up to +170°C and lubricants at temperatures up to +200°C.

- **Code G:**

Non-elastomer material with a graphite base used for high temperature applications. Withstands temperatures up to +400°C.

- **Code T: Polytetrafluorethylene PTFE.**

High chemical resistance to practically all substances. Withstands temperatures ranging from -200°C to +260°C.

Cartridges identification guide

Working Conditions:

Speed (rpm):

Temperature (°C):

Pressure (bar):

Media:



Solid particles in suspension YES NO

New application: YES NO

Current Product:

Explanation of application:

Dimensions:

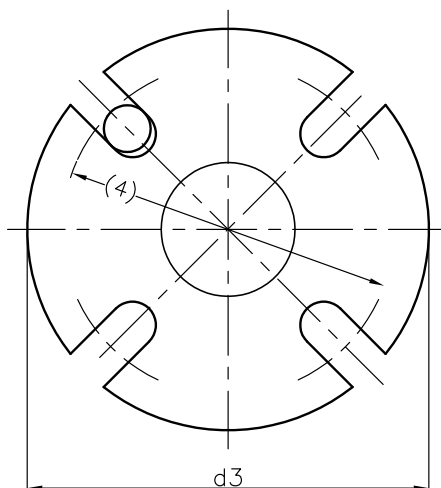
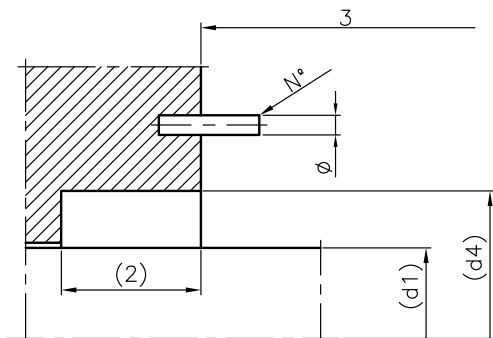

(1) Shaft diameter:

(2) Stuffing box diameter:

(3) Number of bolts and diameter:

N°

Ø

(4) Stuffing box length:

(5) Maximum installation length:

(6) Maximum diameter of gland:

(7) External diameter between bolts:

Seals Identification guide

Company: Work fluids:

Contact person: Solid particles in suspension: YES NO

Pump brand: Model:

Working Conditions:

Temperature: Cleaning: YES NO

Pressure: Conditions:

Speed:

Rotary Part / Face:

Spring:

Single spring

Multi-spring

Wave spring

Others

Specify

Direction of rotation:

Right

Left

Independent

Example:



Stationary Part:

Example:

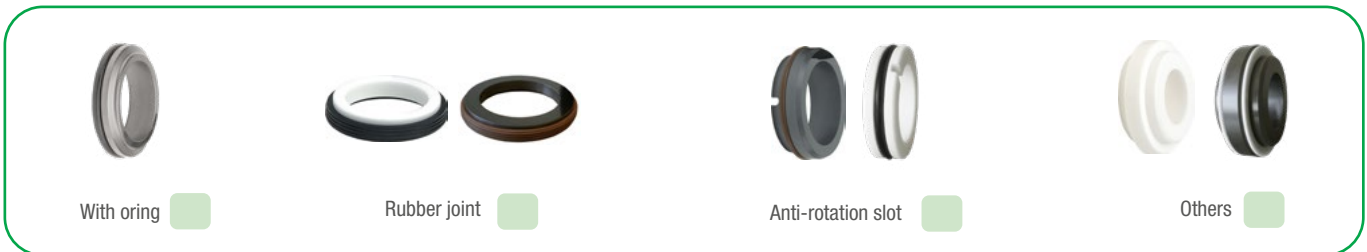

Dimensions (Sketch):

- Shaft diameter (d1): _____
- Exterior diameter of the rotary part (d3): _____
- Length of the rotary part, relaxed (without movement): _____
- Length of the rotary part, totally pressed: _____
- Length of the rotary part in working position (l3): _____
- Exterior diameter of the stationary part, oring includes (d7): _____
- High of the stationary part, from the rotating seal face till the end of the oring (l4): _____

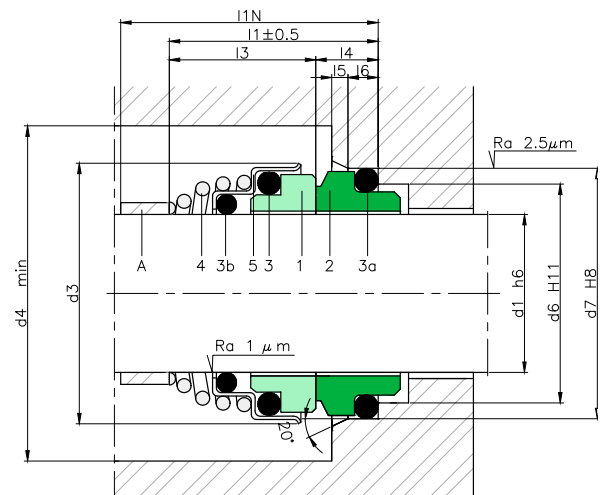

Naming Codes:

Single Cartridge:

L

SC

Type

-

Shaft

-

D: Drainage

F: Flush

QO: quench with lip seal

QG: quench with trough a throttle ring

AB: ANSI Big Bore

AS: ANSI Standard Bore

Double Cartridge:

L

DC

Type

-

Shaft

-

D: Drainage

AB: ANSI Big Bore

AS: ANSI Standard

Single Seals:

L

MS

Type

-

Shaft

-

D

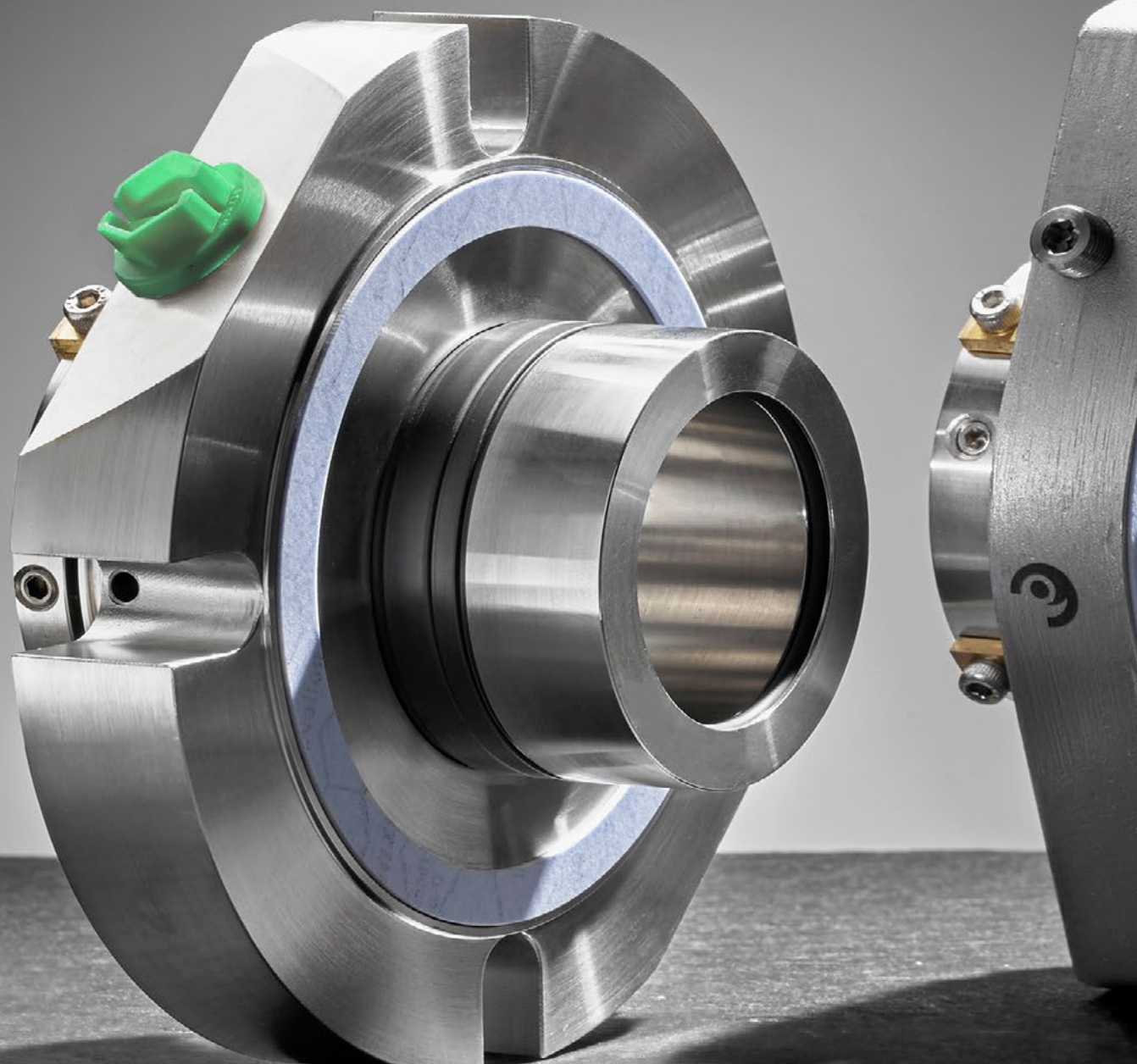

Mechanical Seals

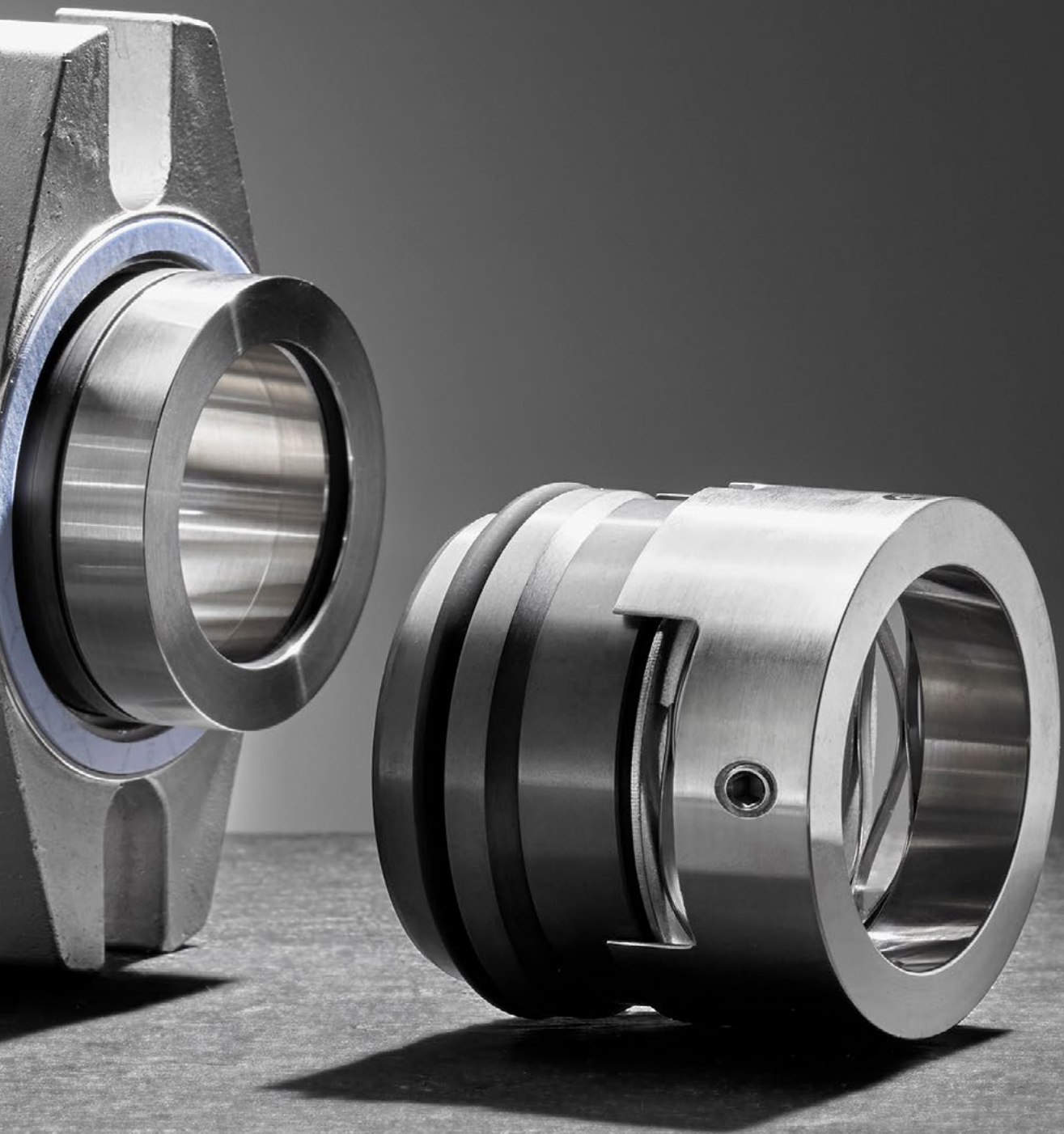

Sectors

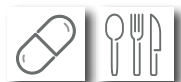

Food and pharma

The food and pharma sectors are especially demanding with respect to safety in their processes. It is very important to prevent contamination with the manufactured products and the halting of production lines during the entire work flow.

For this reason, the use of CIP (Cleaning in place) or SIP (Sterilisation in place) processes is quite usual.

The complex chemical mixtures (alkaline solutions) used in CIP processes may damage the seals of the mechanical seals in a short time, and in SIP, high temperatures reaching values of up to 150° C can destroy conventional elastomer materials.

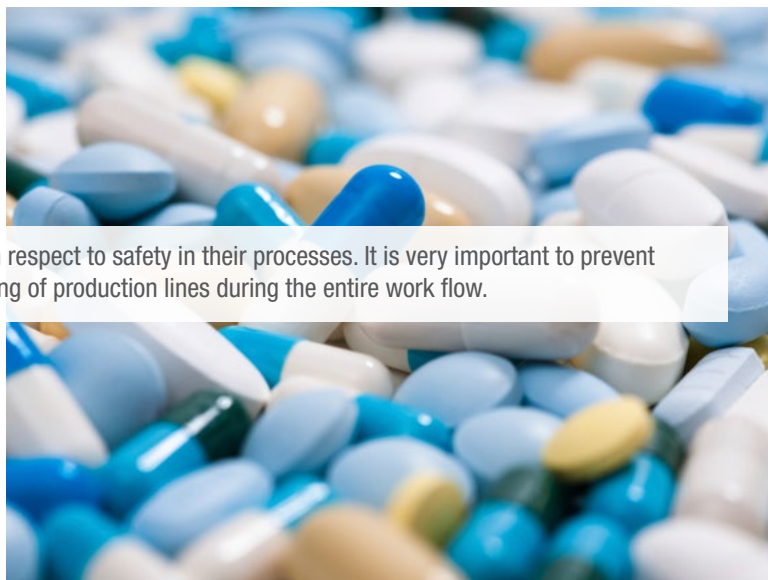

Due to these extreme conditions, the use of elastomers in resistant materials such as EPDM peroxide, FFKM and Aflas® is essential, and they must also comply with the strictest compulsory standards required in these industries: FDA, CE 1935, KTW, WRAS, 3-A, etc.

Many different kinds of machines exist for transferring temperature-sensitive products, viscous substances, fluids with particles or particles in suspension: screw pumps, stirrers, mills, homogenisers, reactors and mixers. The most appropriate mechanical seal design is the hygienic one which reduces the possibility of product remains being deposited and not eliminated during CIP/SIP processes, which could give rise to sources of contamination.

Applications	Requirements or critical conditions of the application	Type of seal recommended
Sauces:	Fluids containing particles	→ Wave spring seal (protected spring), conical spring seal, multispring seal (double) and single cartridge seal.
Sweets and chocolate	Viscous products Products with a high sugar content	→ Double cartridge seal, reservoirs, wave spring seal (protected spring) and bellows seal (metal).
Water and soft drinks:	Fluids without particles	→ Conical spring seal and bellows seal.
Beer:	CIP/SIP processes	→ Conical spring seal and wave spring seal (protected spring).
Dairy products (milk, yoghourts, butter, cheese, fats...)	Viscous products CIP/SIP processes	→ Wave spring seal (protected spring), conical spring seal and multispring seal (protected).
Creamy products, ointments, cosmetics, gels, etc	Viscous and sticky products	→ Multispring seal (double), double cartridge seal, reservoirs and wave spring seal (protected spring).

Determining the mechanical seal design and the appropriate materials for each application is essential in order to cut costs.

Sector



Chemical



In the chemical industry, the habitual processes require sealing elements for materials with high chemical resistance. For transferring very aggressive or corrosive chemical fluids that are clean or with particles and have high viscosities, along with high temperatures and pressures, the mechanical seal materials and the type of assembly must be correctly defined: single, double, external or in accordance with API plans.

Furthermore, the applications require sealing systems that guarantee safety, preventing the leakage of corrosive or flammable products that could enter the atmosphere. In this sector the ATEX certification is often required, to ensure equipment's safety when working in explosive environments.



All the above gives rise to extremely demanding requirements for the mechanical seals and for the auxiliary elements supplied with them: LTS or LQT reservoirs, or elements such as cyclones.

Not only is it necessary to pay attention to the design of the mechanical seal, but also to consider the materials used to make its components: sintered silicon carbide contact surfaces (Q1), fluorinated elastomeric seals (FKM) or high resistance alloy springs (Hastelloy®C) are an indispensable requirement.

Applications	Requirements or critical conditions of the application	Type of seal recommended
Chlorine and its by-products, acids, caustic products:	Corrosive fluids	→ Bellows seal (PTFE).
Detergents:	Viscous products	→ Multispring seal (double).
Fertilisers:	Chemically aggressive fluids	→ Bellows seal (PTFE).
Varnishes and paints:	Sticky products	→ Double cartridge seal, reservoirs and wave spring seal.
Pulp and paper:	Paste-like products	→ Double cartridge seal, reservoirs, multispring seal, (external arrangement) and wave spring seal.

Sector



Water treatment

In water treatment operations, different processes are carried out in order to obtain a product that complies with the stringent health and legal legislation of each country.

Even though water is the main element of the whole process and the main fluid used, the difficulties posed in sealing it are just as challenging as in other sectors.

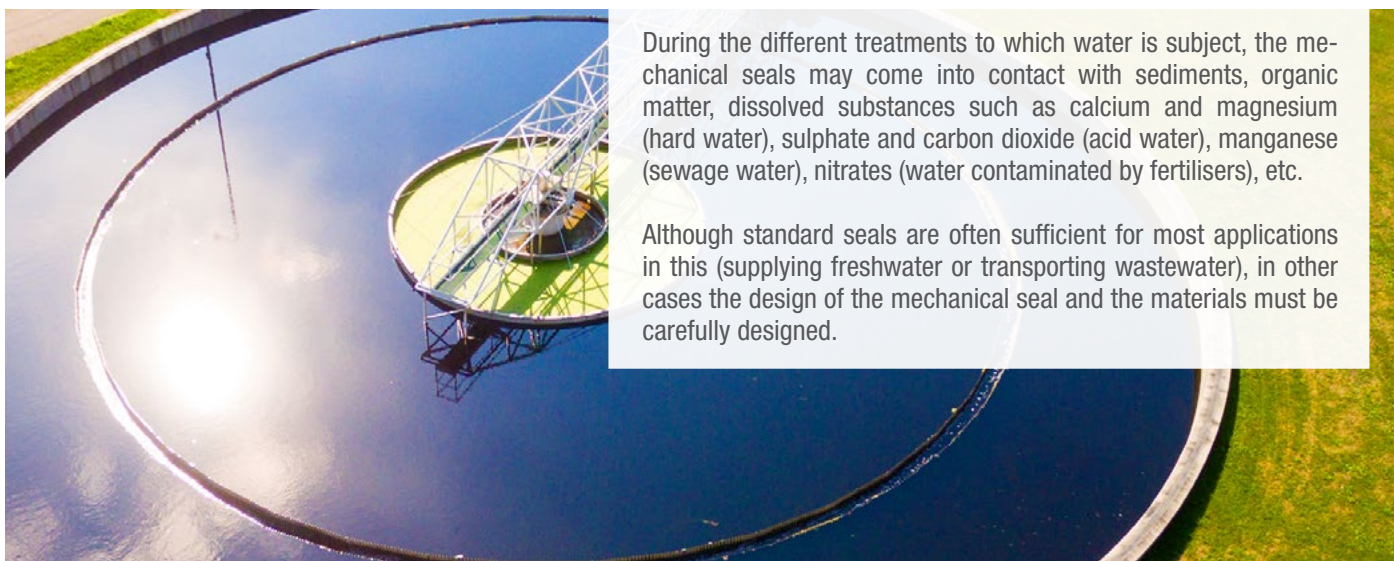
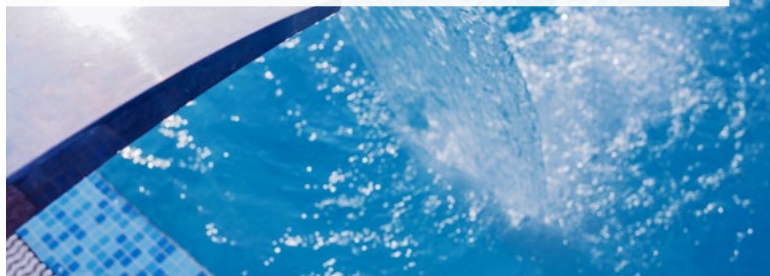
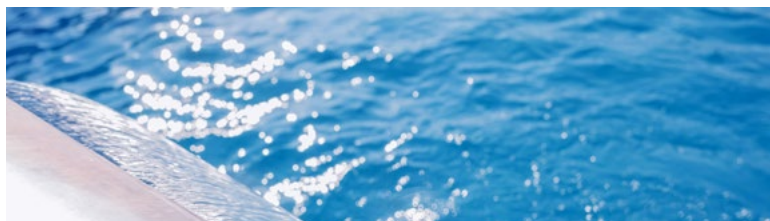

During the different treatments to which water is subject, the mechanical seals may come into contact with sediments, organic matter, dissolved substances such as calcium and magnesium (hard water), sulphate and carbon dioxide (acid water), manganese (sewage water), nitrates (water contaminated by fertilisers), etc.

Although standard seals are often sufficient for most applications in this (supplying freshwater or transporting wastewater), in other cases the design of the mechanical seal and the materials must be carefully designed.

Applications	Requirements or critical conditions of the application	Type of seal recommended
Domestic water treatment		→ Bellows seal and conical spring seal.
Desanding/degreasing treatment Decanting	Fluids with a high particle content	→ Single cartridge seal, double cartridge seal, auxiliary elements (reservoirs cyclones) and wave spring seal.
Deodorising	Fluids containing chemicals: (sodium hypochlorite, sodium hydroxide, sulphuric acid)	→ Bellows Seal (PTFE).

Sector



Maritime



Pumps installed on ships must be extremely reliable and durable. Use of different machines: cooling pumps, fire fighting pumps or boiler supply pumps, meaning that the types of mechanical seals used in this industry are quite diverse. The main applications are for:

- Cooling machinery
- Firefighting systems.
- Feeding boilers.
- Pumping ballast water.



A wide range of mechanical seal designs exist for this type of pumps, which operates in especially difficult conditions with high salt concentrations (this parameter varies, depending on the sea), at high pressures, etc.

Within this scope, not only is it important to locate spare parts to make the repair, but it is also important to select the right materials for the contact surfaces and metal parts of the seal. It is essential to determine a structure that permits easy mounting, increases the pump's useful life and reduces maintenance costs.

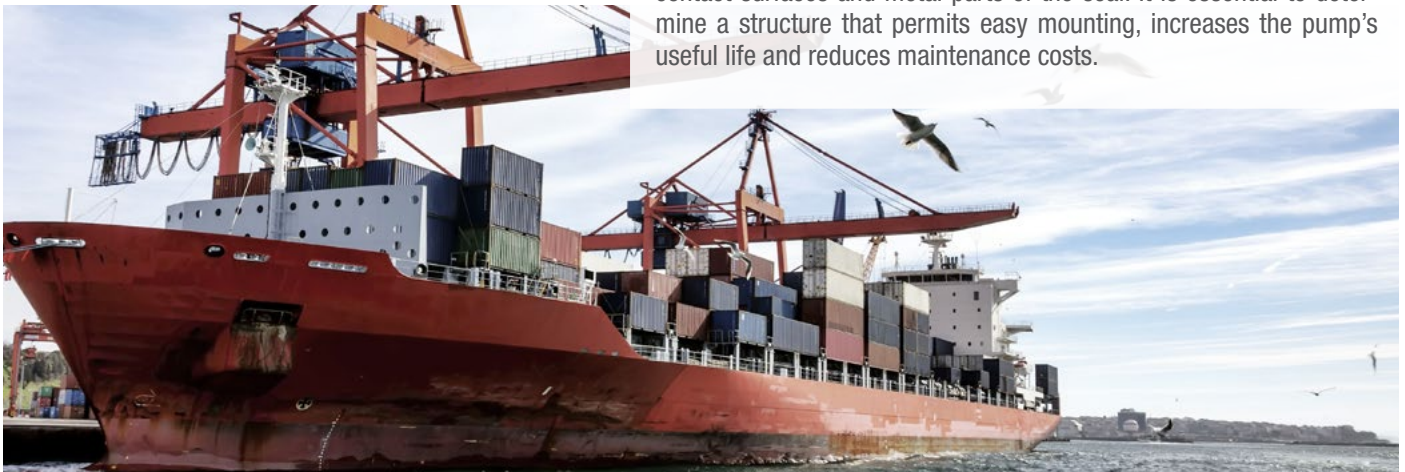

Applications	Requirements or critical conditions of the application	Type of seal recommended
Sea water:	High salt concentration High pressure	→ Multispring seal: Hastelloy®C materials multispring seal (balanced)
	Complex assemblies	→ Single cartridge seal (split).
Sump pumps:	High salt concentration	→ Single cartridge seal, axial spring seals: conical spring, wave spring seal and multispring seal.

Sector	Double cartridge seal	Single cartridge seal	Auxiliary elements	Wave spring seal	Multispring seals	Axial spring seals	Bellows seals
Food & Beverage	•	•	•	•	•	•	•
Pharmaceutical	•		•	•	•	•	
Chemical	•		•	•	•		•
Water treatment	•	•	•	•		•	•
Maritime		•		•	•	•	•

LMS10D



COMPONENTS:

- 1 Rotating contact surface
- 1a Rotating contact surface
- 2 Stationary contact surface
- 2a Stationary contact surface
- 3 O-rings
- 3a O-rings
- 3b O-rings
- 3c O-rings
- 4 Springs
- 5 Metal frame
- 5a Set screws
- 5b Ring

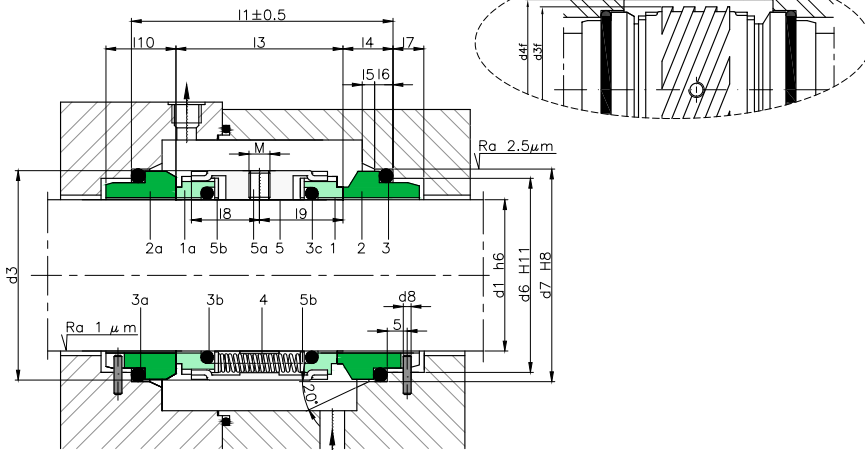

SECTORS:



CHARACTERISTICS:

- Unbalanced.
- System attached to the shaft by allen screws.
- Not dependent on the rotation direction.

OPERATING LIMITS:

$d_1 = 18 \div 100 \text{ mm}$ $p = 16 \text{ kg/cm}^2$
 $v = 20 \text{ m/s}$ $t = -15 \div +200^\circ\text{C} (*)$

(*) The temperature resistance depends on the material of the secondary seals used.

The operating limits are defined by the PV factor which is determined for the sealing system characteristics and those of the application.

DESCRIPTION:

Double seal for working with barrier fluids in which the springs are isolated from the fluid product. API 53A and API54 assemblies.

Recommended in applications with toxic, pollutant or potentially dangerous products in which safety is an important factor. Available with a pumping ring on the casing to reduce the temperature between the contact surfaces and facilitate the barrier fluid movement (reference LMS10D-F). Available in a balanced version with a stepped shaft (reference LM10BD). Contact surface kits available.

DIMENSIONS CHART

Dimensions in mm

Shaft mm	Rotary part							Stationary part							Total length l ₁	
	d ₃	d _{3f}	d _{4f}	l ₃	l ₈	l ₉	M	d ₆	d ₇	d ₈	l ₄	l ₅	l ₆	l ₇		l ₁₀
18	33	-	-	38	17.0	19.0	M5	27	33	3	11.5	2.0	5	9	19.5	61.0
20	35	-	-	38	17.0	19.0	M5	29	35	3	11.5	2.0	5	9	19.5	61.0
22	37	42	42,5	38	17.0	19.0	M5	31	37	3	11.5	2.0	5	9	19.5	61.0
24	39	44	44,5	38	17.0	19.0	M5	33	39	3	11.5	2.0	5	9	19.5	61.0
25	40	45	45,5	38	17.0	19.0	M5	34	40	3	11.5	2.0	5	9	19.5	61.0
28	43	47	47,5	39	17.5	19,5	M6	37	43	3	11,5	2,0	5	9	19,5	62,0
30	45	49	49,5	39	17,5	19,5	M6	39	45	3	11,5	2,0	5	9	19,5	62,0
32	47	51	51,5	39	17,5	19,5	M6	42	48	3	11,5	2,0	5	9	19,5	62,0
33	48	51	51,5	39	17,5	19,5	M6	42	48	3	11,5	2,0	5	9	19,5	62,0
35	50	54	54,5	39	17,5	19,5	M6	44	50	3	11,5	2,0	5	9	19,5	62,0
38	55	59	59,5	41	18,5	20,5	M6	49	56	4	14,0	2,0	6	9	22,0	69,0
40	57	61	61,5	42	19,0	21,0	M6	51	58	4	14,0	2,0	6	9	22,0	70,0
43	60	65	65,5	42	19,0	21,0	M6	54	61	4	14,0	2,0	6	9	22,0	70,0
45	62	66	66,5	42	19,0	21,0	M6	56	63	4	14,0	2,0	6	9	22,0	70,0
48	65	69	69,5	42	19,0	21,0	M6	59	66	4	14,0	2,0	6	9	22,0	70,0
50	67	71	71,5	43	19,5	21,5	M6	62	70	4	15,0	2,5	6	9	23,0	73,0
53	70	75	75,5	43	19,5	21,5	M6	65	73	4	15,0	2,5	6	9	23,0	73,0
55	72	76	76,5	43	19,5	21,5	M8	67	75	4	15,0	2,5	6	9	23,0	73,0
58	79	83	83,5	56	23,5	28,0	M8	70	78	4	15,0	2,5	6	9	23,0	86,0
60	81	85	85,5	56	23,5	28,0	M8	72	80	4	15,0	2,5	6	9	23,0	86,0
63	84	88	88,5	55	24,5	27,5	M8	75	83	4	15,0	2,5	6	9	-	85,0
65	86	95	95,5	55	24,5	27,5	M8	77	85	4	15,0	2,5	6	9	23,0	85,0
68	89	93	93,5	55	24,5	27,5	M8	81	90	4	18,0	2,5	7	9	26,0	91,0
70	91	95	95,5	56	23,5	28,0	M8	83	92	4	18,0	2,5	7	9	26,0	92,0
75	99	105	105,5	56	25,5	28,0	M8	88	97	4	18,0	2,5	7	9	26,0	92,0
80	104	109	109,5	56	25,5	28,0	M8	95	105	4	18,2	3,0	7	9	26,2	92,5
85	100	114	114,5	56	25,0	28,0	M8	100	110	4	18,2	3,0	7	9	26,2	92,5
90	114	119	119,5	56	25,5	28,0	M8	105	115	4	18,2	3,0	7	9	26,2	92,5
95	119	124	124,5	56	25,0	28,0	M8	110	120	4	17,2	3,0	7	9	25,2	90,5
100	124	129	129,5	56	25,0	28,0	M8	115	125	4	17,2	3,0	7	9	25,2	90,5

Dimensions subject to changes or modifications.

LMS11



COMPONENTS:

- 1 Rotating contact surface
- 2 Stationary contact surface
- 3 O-rings
- 3a O-rings
- 4 Springs
- 5 Metal frame
- 5a Set screws
- 5b Ring

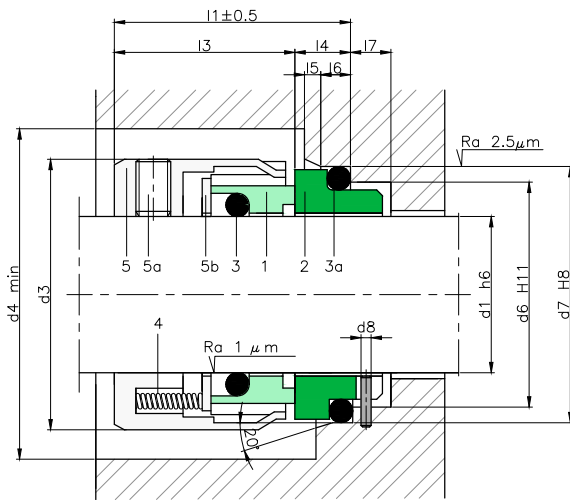

SECTORS:



CHARACTERISTICS:

- Unbalanced.
- System attached to the shaft by allen screws.
- Not dependent on the rotation direction.

OPERATING LIMITS:

$d_1 = 18 \div 100 \text{ mm}$ $p = 10 \text{ kg/cm}^2$

$v = 20 \text{ m/s}$ $t = -15 \div +200^\circ\text{C} (*)$

(*) The temperature resistance depends on the material of the secondary seals used.

The operating limits are defined by the PV factor which is determined for the sealing system characteristics and those of the application.

DESCRIPTION:

The contact surface of the rotating part can be detached, which makes this model extremely versatile as it is easy to exchange contact surfaces made of different materials.

Seal compliant with standard EN 12756.

DIMENSIONS CHART

Dimensions in mm

Shaft mm	Rotary part			Stationary part							Total length l ₁
	d ₃	d ₄	l ₃	d ₆	d ₇	d ₈	l ₄	l ₅	l ₆	l ₇	
18	32	37	21.0	27	33	3	10.0	2.0	4	9	31
20	34	39	21.0	29	35	3	10.0	2.0	5	9	31
22	36	41	21.0	31	37	3	10.0	2.0	5	9	31
24	38	43	24.0	33	39	3	10.0	2.0	5	9	34
25	39	44	24.0	34	40	3	10.0	2.0	5	9	34
28	42	47	24.0	37	43	3	10.0	2.0	5	9	34
30	44	49	25.0	39	45	3	10.0	2.0	5	9	35
32	46	51	25.0	42	48	3	10.0	2.0	5	9	35
33	47	52	25.0	42	48	3	10.0	2.0	5	9	35
35	49	54	25.0	44	50	3	10.0	2.0	5	9	35
38	54	59	28.0	49	56	4	11.0	2.0	6	9	39
40	56	61	28.0	51	58	4	11.0	2.0	6	9	39
43	59	64	28.0	54	61	4	11.0	2.0	6	9	39
45	61	66	28.0	56	63	4	11.0	2.0	6	9	39
48	64	69	28.0	59	66	4	11.0	2.0	6	9	39
50	66	71	28.0	62	70	4	13.0	2.5	6	9	41
53	69	74	28.0	65	73	4	13.0	2.5	6	9	41
55	71	76	28.0	67	75	4	13.0	2.5	6	9	41
58	78	83	29.0	70	78	4	13.0	2.5	6	9	42
60	80	85	29.0	72	80	4	13.0	2.5	6	9	42
63	83	88	32.0	75	83	4	13.0	2.5	6	9	45
65	85	90	32.0	77	85	4	13.0	2.5	6	9	45
68	88	93	32.7	81	90	4	15.3	2.5	7	9	48
70	90	95	32.7	83	92	4	15.3	2.5	7	9	48
75	99	104	36.7	88	97	4	15.3	2.5	7	9	52
80	104	109	36.3	95	105	4	15.7	3.0	7	9	52
85	109	114	36.3	100	110	4	15.7	3.0	7	9	52
90	114	119	39.3	105	115	4	15.7	3.0	7	9	55
95	119	124	39.3	110	120	4	15.7	3.0	7	9	55
100	124	129	39.3	115	125	4	15.7	3.0	7	9	55

Dimensions subject to changes or modifications.

LMS13



COMPONENTS:

- 1 Rotating contact surface
- 2 Stationary contact surface
- 3 O-rings
- 3a O-rings
- 4 Springs
- 5 Metal frame
- 5a Set screws
- 5b Ring

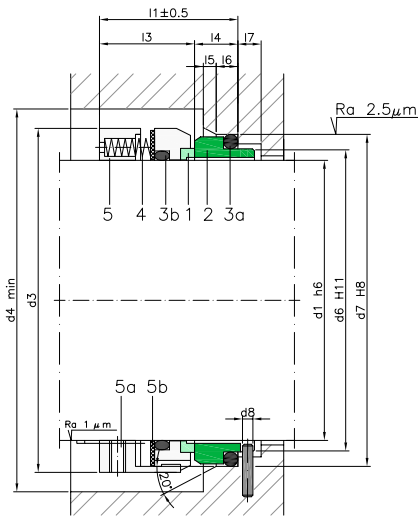

SECTORS:



CHARACTERISTICS:

- Unbalanced.
- System attached to the shaft by allen screws.
- Not dependent on the rotation direction.

OPERATING LIMITS:

$d_i = 20 \div 100 \text{ mm}$ $p = 12 \text{ kg/cm}^2$

$v = 20 \text{ m/s}$ $t = -40 \div +200^\circ\text{C}$ (*)

(*) The temperature resistance depends on the material of the secondary seals used.

The operating limits are defined by the PV factor which is determined for the sealing system characteristics and those of the application.

DESCRIPTION:

The contact surface of the rotating part can be detached, which makes this model extremely versatile as it is easy to exchange contact surfaces made of different materials.

Seal compliant with standard EN 12756.

DIMENSIONS CHART

Dimensions in mm

Shaft mm	Rotary part			Stationary part							Total length l ₁
	d ₃	d ₄	l ₃	d ₆	d ₇	d ₈	l ₄	l ₅	l ₆	l ₇	
20	34	36	27,5	29,0	35,0	3,0	10,0	2,0	5,0	9,0	37,5
22	36	38	27,5	31,0	37,0	3,0	10,0	2,0	5,0	9,0	37,5
24	38	40	30,0	33,0	39,0	3,0	10,0	2,0	5,0	9,0	40,0
25	39	41	30,0	34,0	40,0	3,0	10,0	2,0	5,0	9,0	40,0
28	42	44	32,5	37,0	43,0	3,0	10,0	2,0	5,0	9,0	42,5
30	44	46	32,5	39,0	45,0	3,0	10,0	2,0	5,0	9,0	42,5
32	46	48	32,5	42,0	48,0	3,0	10,0	2,0	5,0	9,0	42,5
33	47	49	32,5	42,0	48,0	3,0	10,0	2,0	5,0	9,0	42,5
35	49	51	32,5	44,0	50,0	3,0	10,0	2,0	5,0	9,0	42,5
38	54	58	34,0	49,0	56,0	4,0	11,0	2,0	6,0	9,0	45,0
40	56	60	34,0	51,0	58,0	4,0	11,0	2,0	6,0	9,0	45,0
43	59	63	34,0	54,0	61,0	4,0	11,0	2,0	6,0	9,0	45,0
45	61	65	34,0	56,0	63,0	4,0	11,0	2,0	6,0	9,0	45,0
48	64	68	34,0	59,0	66,0	4,0	11,0	2,0	6,0	9,0	45,0
50	66	70	34,5	62,0	70,0	4,0	13,0	2,5	6,0	9,0	47,5
53	69	73	34,5	65,0	73,0	4,0	13,0	2,5	6,0	9,0	47,5
55	71	75	34,5	67,0	75,0	4,0	13,0	2,5	6,0	9,0	47,5
58	78	83	39,5	70,0	78,0	4,0	13,0	2,5	6,0	9,0	52,5
60	80	85	39,5	72,0	80,0	4,0	13,0	2,5	6,0	9,0	52,5
63	83	88	39,5	75,0	83,0	4,0	13,0	2,5	6,0	9,0	52,5
65	85	90	39,5	77,0	85,0	4,0	13,0	2,5	6,0	9,0	52,5
68	88	93	37,5	81,0	90,0	4,0	15,0	2,5	7,0	9,0	52,5
70	90	95	45,0	83,0	92,0	4,0	15,0	2,5	7,0	9,0	60,0
75	99	104	45,0	88,0	97,0	4,0	15,0	2,5	7,0	9,0	60,0
80	104	109	44,5	95,0	105,0	4,0	15,5	3,0	7,0	9,0	60,0
85	109	114	44,5	100,0	110,0	4,0	15,5	3,0	7,0	9,0	60,0
90	114	119	49,5	105,0	115,0	4,0	15,5	3,0	7,0	9,0	65,0
95	119	124	49,5	110,0	120,0	4,0	15,5	3,0	7,0	9,0	65,0
100	124	129	49,5	115,0	125,0	4,0	15,5	3,0	7,0	9,0	65,0

Dimensions subject to changes or modifications.

LMS14



COMPONENTS:

- 1 Rotating contact surface
- 2 Stationary contact surface
- 3a O-rings
- 3b O-rings
- 3c O-rings
- 4 Springs
- 5 Metal frame
- 5a Set screws
- 5b Coupling pin

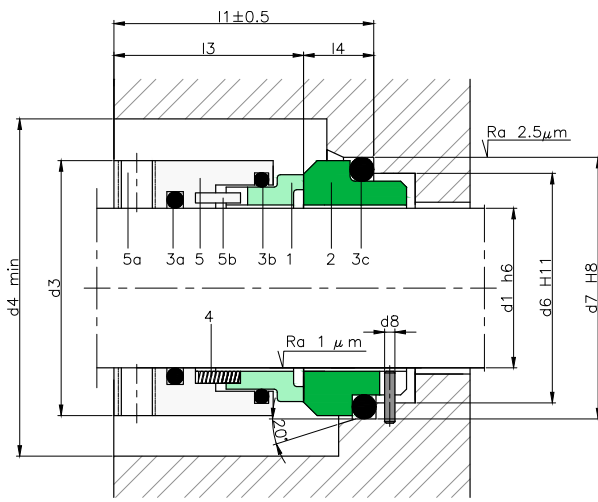

SECTORS:



CHARACTERISTICS:

- **Balanced.**
- System attached to the shaft by allen screws.
- **Not dependent on the rotation direction.**

OPERATING LIMITS:

$d_1 = 18 \div 100 \text{ mm}$ $p = 14 \text{ kg/cm}^2$
 $v = 15 \text{ m/s}$ $t = -15 \div +200^\circ\text{C}$ (*)

(*) The temperature resistance depends on the material of the secondary seals used.

The operating limits are defined by the PV factor which is determined for the sealing system characteristics and those of the application.

DESCRIPTION:

The springs are not in contact with the fluid. Ideal for working with particle-laden fluids in which standard designs tend to become blocked. Internally balanced, with no need for a stepped shaft. Suitable for working in applications with high pressures. The O-ring resting on the shaft does not cause wear as there is no axial movement (changes in pressure).

DIMENSIONS CHART

Dimensions in mm

Shaft	Rotary part			Stationary part				Total length
	d ₃	d ₄	l ₃	d ₆	d ₇	d ₈	l ₄	
18	33	36	32	27	33	3	13.5	45.5
20	35	38	32	29	35	3	13.5	45.5
22	37	40	32	31	37	3	13.5	45.5
24	39	42	32	33	39	3	13.3	45.3
25	40	43	32	34	40	3	13.0	45.0
28	43	46	32	37	43	3	12.5	44.5
30	45	48	32	39	45	3	12.0	44.0
32	47	50	42	42	48	3	12.0	54.0
33	48	51	42	42	48	3	12.0	54.0
35	50	53	42	44	50	3	12.0	54.0
38	55	58	42	49	56	3	13.0	55.0
40	57	60	42	51	58	3	13.0	55.0
43	60	63	42	54	61	4	13.0	55.0
45	62	65	42	56	63	4	13.0	55.0
48	65	68	42	59	66	4	13.0	55.0
50	67	70	42	62	70	4	13.5	55.5
53	70	73	42	65	73	4	13.5	55.5
55	72	75	42	67	75	4	13.5	55.5
58	79	82	42	70	78	4	13.5	55.5
60	81	84	42	72	80	4	13.5	55.5
65	86	89	42	77	85	4	13.5	55.5
68	89	92	42	81	90	4	13.5	55.5
70	91	94	42	83	92	4	14.5	56.5
75	99	102	48	88	97	4	14.5	62.5
80	104	107	48	95	105	4	15.0	63.0
85	109	112	48	100	110	4	15.0	63.0
90	114	117	48	105	115	4	15.0	63.0
95	119	122	48	110	120	4	15.0	63.0
100	124	127	48	115	125	4	15.0	63.0

Dimensions subject to changes or modifications.

Dimensions in inches

Shaft	Rotary part			Stationary part				Total length
	(*) mm	d ₃	d ₄	l ₃	d ₆	d ₇	l ₄	
0,750	19,05	34	37	32	29,9	34,9	6,6	38,6
0,875	22,23	36	39	32	33,1	38,1	6,6	38,6
1,000	25,40	39	42	32	36,3	41,3	6,6	38,6
1,125	28,58	43	46	32	39,5	44,5	6,6	38,6
1,250	31,75	46	49	32	42,6	47,6	6,6	38,6
1,375	34,93	49	52	32	45,8	50,8	6,6	38,6
1,500	38,10	54	57	32	47,6	54	7,5	39,5
1,625	41,28	57	60	32	53,9	60,3	8,2	40,2
1,750	44,45	60	63	42	57,1	63,5	8,2	50,2
1,875	47,63	64	67	42	60,3	66,7	8,2	50,2
2,000	50,80	67	70	42	63,5	69,9	8,2	50,2
2,125	53,98	70	73	42	69,8	76,2	9,5	51,5
2,250	57,15	73	76	42	73	79,4	9,5	51,5
2,375	60,33	76	79	42	76,2	82,6	9,5	51,5
2,500	63,50	79	82	42	79,3	85,7	9,5	51,5
2,625	66,68	83	86	42	79,3	85,7	9,5	51,5
2,750	69,85	92	95	42	82,5	88,9	9,5	51,5
2,875	73,03	95	98	42	85,3	95,3	11,3	53,3
3,000	76,20	98	101	42	88,4	98,4	11,3	53,3
3,125	79,38	101	104	42	91,6	101,6	14,3	56,3
3,250	82,55	104	107	42	94,8	104,8	14,3	56,3
3,375	85,73	107	110	42	98	108	14,3	56,3
3,500	88,90	111	114	42	101,1	111,1	14,3	56,3
3,625	92,08	114	117	42	104,3	114,3	14,3	56,3
3,750	95,25	117	120	48	107,5	117,5	14,3	62,3
3,875	98,43	120	123	48	110,7	120,7	14,3	62,3
4,000	101,60	123	126	48	113,8	123,8	14,3	62,3

LMS15D



COMPONENTES:

- 1 Rotating contact surface
- 1a Rotating contact surface
- 2 Stationary contact surface
- 2a Stationary contact surface
- 3a O-rings
- 3b O-rings
- 3c O-rings
- 4 Springs
- 5 Metal frame
- 5a Set screws

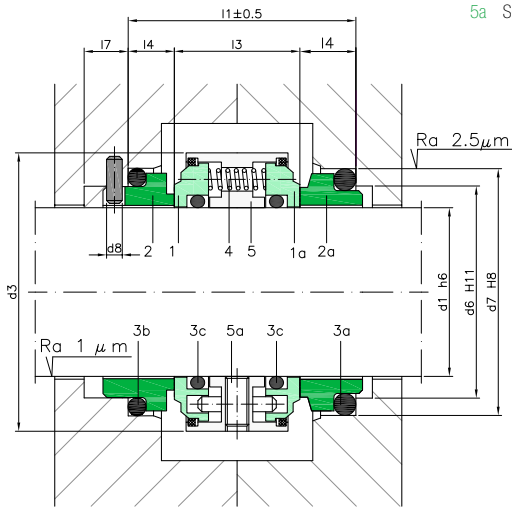

SECTORS:



CHARACTERISTICS:

- Unbalanced.
- System attached to the shaft by allen screws.
- Not dependent on the rotation direction.

OPERATING LIMITS:

$d_1 = 20 \div 100 \text{ mm}$ $p = 12 \text{ kg/cm}^2$
 $v = 20 \text{ m/s}$ $t = -40 \div +200^\circ\text{C} (*)$

(*) The temperature resistance depends on the material of the secondary seals used.

The operating limits are defined by the PV factor which is determined for the sealing system characteristics and those of the application.

DESCRIPTION:

Double seal for working with barrier fluids in which the springs are isolated from the fluid product. API 53A and API54 assemblies. Recommended in applications with toxic, pollutant or potentially dangerous products in which safety is an important factor.

DIMENSIONS CHART

Dimensions in mm

Shaft	Rotary part		Stationary part					Total length
mm	d_3	l_3	d_6	d_7	d_8	l_4	l_7	l_1
20	40	23	29	35	3	10	9	43
25	44,5	25	34	40	3	10	9	45
28	47,5	25	37	43	3	8,5	9	42
30	50	27	39	45	3	10	9	47
35	56	28,5	44	50	3	10	9	48,5
43	71	30	54	61	4	13	9	56
50	80	30	62	70	4	14	9	58
65	98	35	77	85	4	14	9	63
100	145	45	115	125	4	16	9	81

Dimensions subject to changes or modifications.

LMS20 / LMS20T



COMPONENTS:

- 1 Rotating contact surface
- 2 Stationary contact surface
- 3 O-rings
- 3T PTFE wedge
- 3a O-rings
- 3Ta PTFE gasket
- 4 Springs
- 5 Metal frame
- 5a Set screws
- 5b Ring

SECTORS:



CHARACTERISTICS:

- **Unbalanced.**
- System attached to the shaft by allen screws.
- **Not dependent on the rotation direction.**

OPERATING LIMITS:

$d_1 = 14 \div 100$ mm $p = 10$ kg/cm²
 $v = 20$ m/s $t = -15 \div +200$ °C (*)

(*) The temperature resistance depends on the material of the secondary seals used.

The operating limits are defined by the PV factor which is determined for the sealing system characteristics and those of the application.

DESCRIPTION:

The set of springs placed around the contact surface of the rotating part generates a more uniform load than in models with a single spring. The LMS20 is suitable for many different applications. Seal compliant with standard EN 12756 (KU). The LMS20T uses a PTFE wedge as a secondary seal and is appropriate for highly aggressive chemicals and for thermal oils with high temperatures. The version in inches has a standard stationary PF. L22 part.

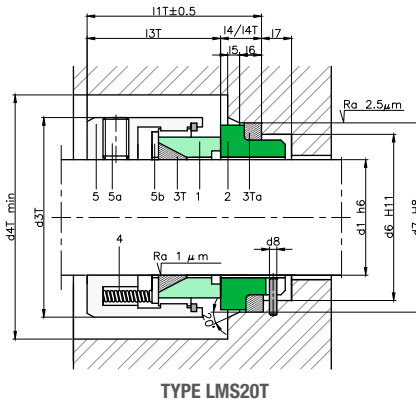
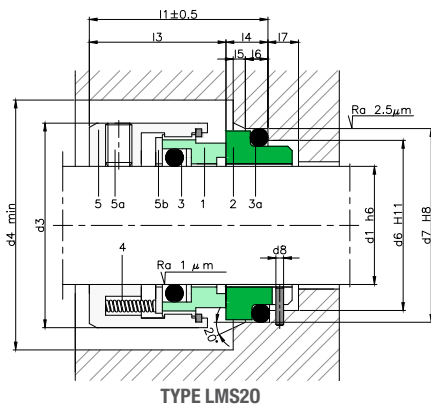

DIMENSIONS CHART

Dimensions in mm

Shaft mm	Rotary part							Stationary part							Total length	
	d ₃	d _{3T}	d ₄	d _{4T}	l ₃	l _{3T}	d ₆	d ₇	d ₈	l ₄	l ₅	l ₆	l ₇	l ₁	l _{1T}	
14	24	28,4	26	31	23	21	21	25	3	12	1,5	4	8,5	35	33	
16	26	30,8	28	34	23	19	23	27	3	12	1,5	4	8,5	35	31	
18	32	33,8	34	36,5	24	22	27	33	3	13,5	2	5	9	37,5	35,5	
20	34	34,8	36	38	24	24	29	35	3	13,5	2	5	9	37,5	37,5	
22	36	35,6	38	39	24	24	31	37	3	13,5	2	5	9	37,5	37,5	
24	38	38,8	40	42	26,7	25	33	39	3	13,3	2	5	9	40	38,3	
25	39	39,8	41	43	27	25	34	40	3	13	2	5	9	40	38	
28	42	43,4	44	46	30	27	37	43	3	12,5	2	5	9	42,5	39,5	
30	44	46,4	46	49	30,5	27	39	45	3	12	2	5	9	42,5	39	
32	46	49,7	48	53	30,5	29	42	48	3	12	2	5	9	42,5	41	
33	47	-	49	-	30,5	-	42	48	3	12	2	5	9	42,5	-	
35	49	51,3	51	54	30,5	29	44	50	3	12	2	5	9	42,5	41	
38	54	54,5	58	58	32	29	49	56	4	13	2	6	9	45	42	
40	56	59,6	60	63	32	35	51	58	4	13	2	6	9	45	48	
43	59	-	63	-	32	-	54	61	4	13	2	6	9	45	-	
45	61	64,7	65	68	32	35	56	63	4	13	2	6	9	45	48	
48	64	67,2	68	70	32	35	59	66	4	13	2	6	9	45	48	
50	66	69,6	70	73	34	35	62	70	4	13,5	2,5	6	9	47,5	48,5	
53	69	-	73	-	34	-	65	73	4	13,5	2,5	6	9	47,5	-	
55	71	77,7	75	81	34	43	67	75	4	13,5	2,5	6	9	47,5	56,5	
58	78	-	83	-	39	-	70	78	4	13,5	2,5	6	9	52,5	-	
60	80	82,7	85	86	39	43	72	80	4	13,5	2,5	6	9	52,5	56,5	
63	83	-	88	-	39	-	75	83	4	13,5	2,5	6	9	52,5	-	
65	85	87,9	90	91	39	43	77	85	4	13,5	2,5	6	9	52,5	56,5	
68	88	-	93	-	39	-	81	90	4	13,5	2,5	7	9	52,5	-	
70	90	92,6	95	96	45,5	43	83	92	4	14,5	2,5	7	9	60	57,5	
75	95	96,3	104	100	45,5	43	88	97	4	14,5	2,5	7	9	60	57,5	
80	104	101,1	109	104	45	43	95	105	4	15	3	7	9	60	58	
85	109	107,7	114	111	45	43	100	110	4	15	3	7	9	60	58	
90	114	112,7	119	116	50	43	105	115	4	15	3	7	9	65	58	
95	119	117,7	124	121	50	43	110	120	4	15	3	7	9	65	58	
100	124	122,7	129	126	50	43	115	125	4	15	3	7	9	65	58	

Dimensions subject to changes or modifications.

Dimensions in inches

Shaft (")	mm	Rotary part							Stationary part							Total length	
		d ₃	d _{3T}	d ₄	d _{4T}	l ₃	l _{3T}	d ₆	d ₇	l ₄	l _{4T}	l ₁	l _{1T}				
0,500	12,70	23,8	26,7	27	29	23,8	20,6	20,4	25,4	5,9	7,9	29,7	28,5				
0,625	15,88	27	30,7	30,2	34	23,8	19	26,8	31,8	6,6	10,3	30,4	29,3				
0,750	19,05	30,2	34	33,3	37	23,8	22,2	29,9	34,9	6,6	10,3	30,4	32,5				
0,875	22,23	33,3	37,2	36,5	40	23,8	23,8	33,1	38,1	6,6	10,3	30,4	34,1				
1,000	25,40	36,5	40,3	39,7	43	25,4	25,4	36,3	41,3	6,6	11,1	32	36,5				
1,125	28,58	39,7	43,5	42,9	46	25,4	27	39,5	44,5	6,6	11,1	32	38,1				
1,250	31,75	42,9	48,3	46	51	25,4	27	42,6	47,6	6,6	11,1	32	38,1				
1,375	34,93	49,2	51,5	52,4	54	35	28,6	45,8	50,8	6,6	11,1	41,6	39,7				
1,500	38,10	49,2	54,6	52,4	58	28,6	28,6	47,6	54	7,5	11,1	36,1	39,7				
1,625	41,28	57,2	61	60,3	64	29,4	35	53,9	60,3	8,2	12,7	37,6	47,7				
1,750	44,45	58,7	64,2	61,9	67	35	35	57,1	63,5	8,2	12,7	43,2	47,7				
1,875	47,63	63,5	67,3	66,7	70	35	35	60,3	66,7	8,2	12,7	43,2	47,7				
2,000	50,80	66,7	70,5	69,9	73	35	35	63,5	69,9	8,2	12,7	43,2	47,7				
2,125	53,98	71,4	76,9	74,6	80	43	43	69,8	76,2	9,5	14,3	52,5	57,3				
2,250	57,15	72,2	80	75,4	83	35	43	73	79,4	9,5	14,3	44,5	57,3				
2,375	60,33	76,2	83,2	79,4	86	43	43	76,2	82,6	9,5	14,3	52,5	57,3				
2,500	63,50	79,4	86,4	82,6	89	35	43	79,3	85,7	9,5	14,3	44,5	57,3				
2,625	66,68	82,6	89,6	85,7	92	43	43	79,3	85,7	9,5	15,9	52,5	59,9				
2,750	69,85	85,7	92,7	88,9	96	43	43	82,5	88,9	9,5	15,9	52,5	59,9				
2,875	73,03	88,9	95,9	92,1	99	43	43	85,3	93,3	11,3	15,9	54,3	59,9				
3,000	76,20	92,1	97,5	95,3	100	43	43	88,4	98,4	11,3	15,9	54,3	59,9				
3,125	79,38	95,3	100,7	98,4	104	43	43	91,6	101,6	14,3	19,8	57,3	62,8				
3,250	82,55	98,4	105,4	101,6	108	43	43	94,8	104,8	14,3	19,8	57,3	62,8				
3,375	85,73	101,6	108,6	104,8	111	43	43	98	108	14,3	19,8	57,3	62,8				
3,500	88,90	104,8	111,8	108	115	43	43	101,1	111,1	14,3	19,8	57,3	62,8				
3,625	92,08	108	115	111,1	118	43	43	104,3	114,3	14,3	19,8	57,3	62,8				
3,750	95,25	111,1	118,1	114,3	121	43	43	107,5	117,5	14,3	19,8	57,3	62,8				
3,875	98,43	114,3	121,3	117,5	124	43	43	110,7	120,7	14,3	19,8	57,3	62,8				
4,000	101,60	117,5	124,5	120,7	127	43	43	113,8	123,8	14,3	19,8	57,3	62,8				

LMS20B / LMS20BT



COMPONENTS:

- 1 Rotating contact surface
- 2 Stationary contact surface
- 3 O-rings
- 3T PTFE wedge
- 3a O-rings
- 3Ta PTFE gasket
- 4 Springs
- 5 Metal frame
- 5a Set screws
- 5b Ring

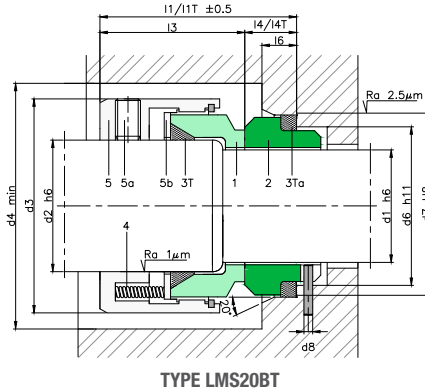
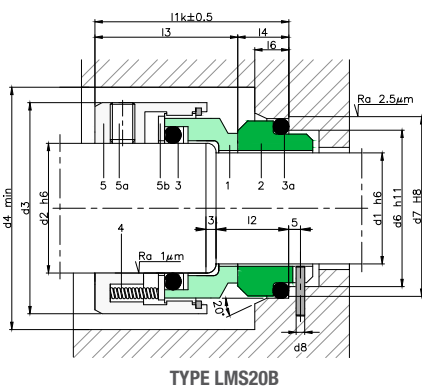

SECTORS:



CHARACTERISTICS:

- **Balanced.**
- System attached to the shaft by allen screws.
- **Not dependent on the rotation direction.**

OPERATING LIMITS:

$d_1 = 14 \div 100 \text{ mm}$ $p = 60 \text{ kg/cm}^2$

$v = 25 \text{ m/s}$

$t = -15 \div +200^\circ\text{C}$ (*)

(*) The temperature resistance depends on the material of the secondary seals used.

The operating limits are defined by the PV factor which is determined for the sealing system characteristics and those of the application.

DESCRIPTION:

The balanced contact surface design allows the mechanical seal to be used in applications with high pressures without suffering premature wear. The set of springs placed around the contact surface of the rotating part generates a more uniform load than in models with a single spring. It can be supplied with PTFE wedge for highly aggressive chemicals with high temperatures. Seal compliant with standard EN 12756 (KB).

DIMENSIONS CHART

Dimensions in mm

Shaft	Rotary part					Stationary part							Total length	
	d ₂	d ₃	d ₄	l ₃	d ₆	d ₇	d ₈	l ₂	l ₄ /l _{4T}	l ₆	l ₇	l ₁ /l _{1T}		
14	18	32	34	30,5	21	25	3	18	12	5,5	8,5		42,5	
16	20	34	36	30,5	23	27	3	18	12	5,5	8,5		42,5	
18	22	36	38	31,5	27	33	3	20	13,5	7	9		45	
20	24	38	40	31,5	29	35	3	20	13,5	7	9		45	
22	26	40	42	31,5	31	37	3	20	13,5	7	9		45	
24	28	42	44	34,2	33	39	3	20	13,3	7	9		47,5	
25	30	44	46	34,5	34	40	3	20	13	7	9		47,5	
28	33	47	49	37,5	37	43	3	20	12,5	7	9		50	
30	35	49	51	38	39	45	3	20	12	7	9		50	
32	38	54	58	38	42	48	3	20	12	7	9		50	
33	38	54	58	38	42	48	3	23	12	7	9		50	
35	40	56	60	38	44	50	3	23	12	7	9		50	
38	43	59	63	39,5	49	56	4	23	13	8	9		52,5	
40	45	61	65	39,5	51	58	4	23	13	8	9		52,5	
43	48	64	68	39,5	54	61	4	23	13	8	9		52,5	
45	50	66	70	39,5	56	63	4	23	13	8	9		52,5	
48	53	69	73	39,5	59	66	4	23	13	8	9		52,5	
50	55	71	75	44	62	70	4	25	13,5	8,5	9		57,5	
53	58	78	83	44	65	73	4	25	13,5	8,5	9		57,5	
55	60	80	85	44	67	75	4	25	13,5	8,5	9		57,5	
58	63	83	88	49	70	78	4	25	13,5	8,5	9		62,5	
60	65	85	90	49	72	80	4	25	13,5	8,5	9		62,5	
65	70	90	95	49	77	85	4	25	13,5	8,5	9		62,5	
70	75	95	104	55,5	83	92	4	28	14,5	9,5	9		70	
75	80	104	109	55,5	88	97	4	28	14,5	9,5	9		70	
80	85	109	114	55	95	105	4	28	15	10	9		70	
85	90	114	119	60	100	110	4	28	15	10	9		75	
90	95	119	124	60	105	115	4	28	15	10	9		75	
95	100	124	129	60	110	120	4	28	15	10	9		75	
100	105	129	134	60	115	125	4	28	15	10	9		75	

Dimensions subject to changes or modifications.

Dimensions in inches

Shaft	Rotary part					Stationary part							Total length	
	(")	mm	d ₂ (")	d ₂ mm	d ₃	d ₄	l ₃	d ₆	d ₇	l ₄	l _{4T}	l ₁	l _{1T}	
0,875	22,23	1,000	25,40	39,67	41,67	33,32	36,3	41,3	6,6	11,1	39,92	44,42		
1,000	25,40	1,125	28,58	42,85	44,85	34,93	39,5	44,5	6,6	11,1	41,53	46,03		
1,125	28,58	1,250	31,75	47,63	35,75	34,93	42,6	47,6	6,6	11,1	41,53	46,03		
1,125	28,58	1,375	34,93	50,8	38,93	36,5	45,8	50,8	6,6	11,1	43,1	47,6		
1,250	31,75	1,500	38,10	53,98	42,10	36,5	47,6	54	7,5	11,1	44	47,6		
1,375	34,93	1,625	41,28	60,33	45,28	44,45	53,9	60,3	8,2	12,7	52,65	57,15		
1,500	38,10	1,750	44,45	63,5	48,45	44,45	57,1	63,5	8,2	12,7	52,65	57,15		
1,625	41,28	1,875	47,63	66,68	51,63	44,45	60,3	66,7	8,2	12,7	52,65	57,15		
1,750	44,45	2,000	50,80	69,85	54,80	44,45	63,5	69,9	8,2	12,7	52,65	57,15		
1,875	47,63	2,125	53,98	76,2	58,98	52,37	69,8	76,2	9,5	14,3	61,87	66,67		
2,000	50,80	2,250	57,15	79,38	62,15	52,37	73	79,4	9,5	14,3	61,87	66,67		
2,125	53,98	2,375	60,33	82,55	65,33	52,37	76,2	82,6	9,5	14,3	61,87	66,67		
2,250	57,15	2,500	63,50	85,73	68,50	52,37	79,3	85,7	9,5	14,3	61,87	66,67		
2,375	60,33	2,625	66,68	88,9	71,68	52,37	79,3	85,7	9,5	15,9	61,87	68,27		
2,500	63,50	2,750	69,85	92,08	74,85	52,37	82,5	88,9	9,5	15,9	61,87	68,27		
2,625	66,68	2,875	73,03	95,25	78,03	52,37	85,3	95,3	11,3	15,9	63,67	68,27		
2,750	69,85	3,000	76,20	96,82	81,20	52,37	88,4	98,4	11,3	15,9	63,67	68,27		
2,875	73,03	3,125	79,38	100	84,38	52,37	91,6	101,6	14,3	19,8	66,67	72,17		
3,000	76,20	3,250	82,55	104,78	87,55	52,37	94,8	104,8	14,3	19,8	66,67	72,17		
3,125	79,38	3,375	85,73	107,95	90,73	52,37	98	108	14,3	19,8	66,67	72,17		
3,250	82,55	3,500	88,90	111,13	93,90	52,37	101,1	111,1	14,3	19,8	66,67	72,17		
3,375	85,73	3,625	92,08	114,3	97,08	52,37	104,3	114,3	14,3	19,8	66,67	72,17		
3,500	88,90	3,750	95,25	117,48	100,25	52,37	107,5	117,5	14,3	19,8	66,67	72,17		
3,625	92,08	3,875	98,43	120,65	103,43	52,37	110,7	120,7	14,3	19,8	66,67	72,17		
3,750	95,25	4,000	101,60	123,83	106,60	52,37	113,8	123,8	14,3	19,8	66,67	72,17		

LMS22



COMPONENTS:

- 1 Rotating contact surface
- 3a O-rings
- 4 Springs
- 5 Metal frame
- 5a Set screws

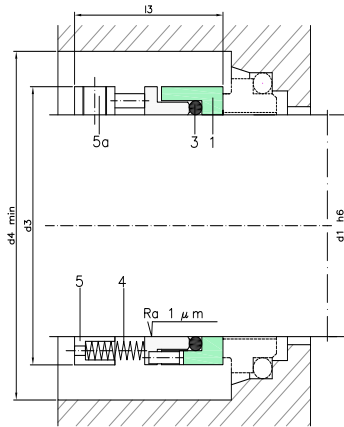

SECTORS:



CHARACTERISTICS:

- Unbalanced.
- System attached to the shaft by allen screws.
- Not dependent on the rotation direction

OPERATING LIMITS:

$d_1 = 20 \div 100 \text{ mm}$ $p = 12 \text{ kg/cm}^2$

$v = 20 \text{ m/s}$ $t = -40 \div +200^\circ\text{C} (*)$

(*) The temperature resistance depends on the material of the secondary seals used.

The operating limits are defined by the PV factor which is determined for the sealing system characteristics and those of the application.

DESCRIPTION:

The contact surface of the rotating part can be detached, which makes this model extremely versatile as it is easy to exchange contact surfaces made of different materials.

DIMENSIONS CHART

Dimensions in mm

Shaft mm	Rotary part		
	d ₃	d ₄	l ₃
20	34	39	35
22	36	41	35
24	38	43	35
25	39	44	35
28	42	47	35
30	44	49	35
32	46	51	35
33	47	52	35
35	49	54	35
38	54	59	38
40	56	61	38
43	59	64	38
45	61	66	38
48	64	69	38
50	66	71	39
53	69	74	40
55	71	76	40
58	76	81	41
60	78	83	41
63	81	86	41
65	83	88	41
68	86	91	41
70	90	95	42
75	95	100	42
80	100	105	42
85	105	110	43
90	110	115	45
95	115	120	45
100	120	125	45

Dimensions in inches

Shaft (")	Rotary part			
	mm	d ₃	d ₄	l ₃
1,00	25,40	39,70	44,70	41,28
1,13	28,58	42,85	47,85	41,28
1,19	30,15	44,45	49,45	41,28
1,25	31,75	46,02	51,02	41,28
1,38	34,93	49,20	54,20	41,28
1,44	36,50	50,80	55,80	41,28
1,50	38,10	52,37	57,37	41,28
1,63	41,28	58,72	63,72	44,45
1,75	44,45	60,33	65,33	44,45
1,88	47,63	65,07	70,07	44,45
2,00	50,80	68,25	73,25	44,45
2,13	53,98	71,42	76,42	44,45
2,25	57,15	74,60	79,60	44,45
2,38	60,33	77,77	82,77	44,45
2,50	63,50	80,95	85,95	44,45
2,63	66,68	84,12	89,12	44,45
2,75	69,85	87,30	92,30	44,45
2,88	73,03	90,47	95,47	44,45
3,00	76,20	93,65	98,65	44,45
3,13	79,38	101,60	106,60	44,45
3,25	82,55	104,78	109,78	44,45
3,38	85,73	107,95	112,95	44,45
3,50	88,90	111,13	116,13	44,45
3,63	92,08	114,30	119,30	44,45
3,75	95,25	117,48	122,48	46,02
3,88	98,43	120,65	125,65	46,02
4,00	101,60	123,83	128,83	46,02
4,25	107,95	130,18	135,18	52,37
4,50	114,30	136,53	141,53	52,37

Dimensions subject to changes or modifications.

LMS26



COMPONENTS:

- 1 Rotating contact surface
- 2 Stationary contact surface
- 3a O-ring
- 4 Spring
- 5 Metal frame
- 6 Ring
- 7 Metal frame
- 8 Setting clips

SECTORS:



CHARACTERISTICS:

- Equilibrado.
- Sistema rotación independiente
- Multimuelle
- External mounting.

OPERATING LIMITS:

$p = 50 \text{ kg/cm}^2$ $v = 50 \text{ m/s}$

$t = -20 \div +140^\circ\text{C}$ (*)

(*) The temperature resistance depends on the material of the secondary seals used.

The operating limits are defined by the PV factor which is determined for the sealing system characteristics and those of the application.

DESCRIPTION:

Balanced mechanical seal with protected springs to prevent them from blocking when in contact with sticky or viscous fluids. The O-ring on the shaft is static, thereby preventing "fretting" of the shaft.

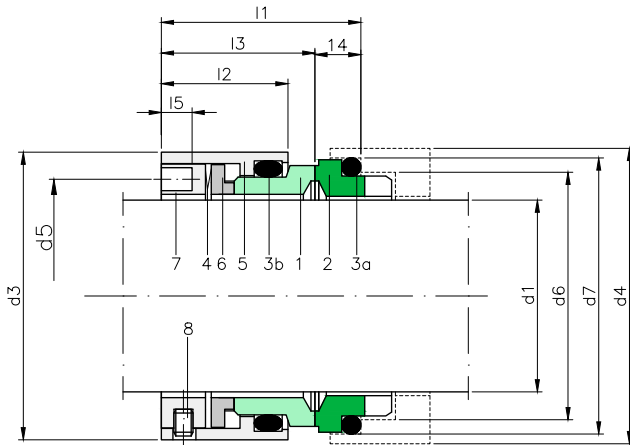

DIMENSIONS CHART

Dimensions in mm

Shaft mm	Rotary part									
	d ₃	d ₄	d ₅	d ₆	d ₇	l ₁	l ₂	l ₃	l ₄	l ₅
40	65	64	52	53.5	59	48.5	30	39	9.5	5
50	75	77	61	63.5	72	54.5	33	42.2	12.3	5
53	80	80	64	66.5	75	55	33.5	42.7	12.3	5
55	85	85	68	71.5	80	60	36.5	47.2	12.8	5
60	90	90	74	76.5	85	61.5	38	48.7	12.8	5
65	95	95	78	81.5	90	62	38	49.2	12.8	5
80	115	119	98	102	110.5	63.5	38	50	13.5	5

Dimensions subject to changes or modifications.

LMS27



COMPONENTS:

- 1 Rotating contact surface
- 2 Stationary contact surface
- 3 O-rings
- 4 Springs
- 5 Metal frame
- 6 Drive ring
- 7 Flange

SECTORS:



CHARACTERISTICS:

- **Balanced.**
- System attached to the shaft by allen screws.
- **Not dependent on the rotation direction.**
- External mounting.

OPERATING LIMITS:

$d_1 = 25 \div 160 \text{ mm}$ $p = \text{empty... } 6 \text{ kg/cm}^2$

$v = 2 \text{ m/s}$ $t = -20 \div +150^\circ\text{C}$ (*)

(*) The temperature resistance depends on the material of the secondary seals used.

The operating limits are defined by the PV factor which is determined for the sealing system characteristics and those of the application.

DESCRIPTION:

A multi-spring mechanical seal recommended for vertical stirrers with moderate speeds. The fixed part may have cooling/lubrication systems: flush and/or cooled flange connection.

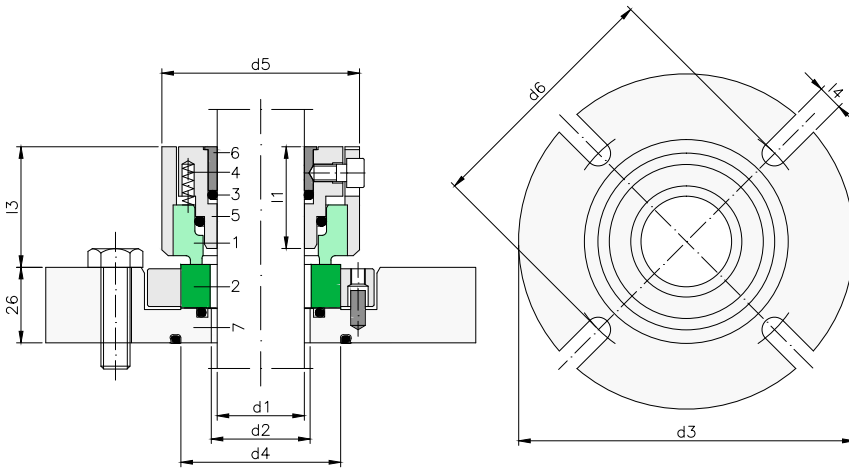

DIMENSIONS CHART

Dimensions in mm

Shaft (") mm	Rotary part			Stationary part						
	l_1	l_3	d_5	d_2	d_3	d_4	$d_{6\text{min}}$	$d_{6\text{max}}$	l_4	
1,00	25	40,5	41,5	68	34	148	-	100	132	11
1,125	28	40,5	41,5	68	34	148	55	100	132	11
-	30	40,5	41,5	68	34	148	55	100	132	11
1,250	32	40,5	41,5	73	39	153	60	105	137	11
1,375	35	40,5	41,5	73	39	153	60	105	137	11
1,500	38	40,5	41,5	78	44	158	65	110	142	11
-	40	40,5	41,5	78	44	158	65	110	142	11
1,625	45	40,5	41,5	83	49	163	68	115	152	11
1,750	-	40,5	41,5	83	49	163	68	115	152	11
1,875	48	40,5	41,5	88	54	178	73	125	160	14
1,125	50	40,5	41,5	88	54	178	75	125	160	14
2,000	55	40,5	41,5	93	59	183	78	130	165	14
2,125	-	40,5	41,5	93	59	183	78	130	165	14
2,250	60	40,5	41,5	98	64	188	85	135	170	14
2,375	65	40,5	44,5	103	69	193	90	140	175	14
2,500	-	40,5	44,5	103	69	193	90	140	175	14
6,625	70	43,5	44,5	108	74	198	95	145	180	14
2,750	-	43,5	44,5	108	74	198	95	145	180	14
2,875	75	43,5	44,5	113	79	203	100	150	185	14

Shaft (") mm	Rotary part			Stationary part						
	l_1	l_3	d_5	d_2	d_3	d_4	$d_{6\text{min}}$	$d_{6\text{max}}$	l_4	
3,000	80	43,5	44,5	118	84	208	105	155	190	14
3,250	85	43,5	44,5	123	89	213	110	160	195	14
3,500	90	43,5	44,5	128	94	218	115	165	200	14
3,750	95	43,5	44,5	133	99	223	120	170	205	14
-	100	43,5	44,5	138	104	228	125	175	210	14
4,000	105	43,5	44,5	143	109	233	130	180	215	14
4,250	110	43,5	44,5	148	114	238	135	185	220	14
4,500	115	43,5	44,5	153	119	267	140	196	243	18
4,750	125	43,5	44,5	163	129	277	150	206	253	18
5,000	140	43,5	44,5	178	144	297	165	221	273	18
5,250	-	43,5	44,5	178	144	297	165	221	273	18
5,500	-	43,5	44,5	178	144	297	165	221	273	18
5,750	150	43,5	44,5	188	154	307	175	231	283	18
6,000	160	43,5	44,5	198	164	317	185	241	283	18
6,250	-	43,5	44,5	198	164	317	185	241	283	18

Dimensions subject to changes or modifications.

LMS28



COMPONENTS:

- 1 Rotating contact surface
- 2 Stationary contact surface
- 3 O-rings
- 3a O-rings
- 4 Springs
- 5 Metal frame
- 5a Set screws

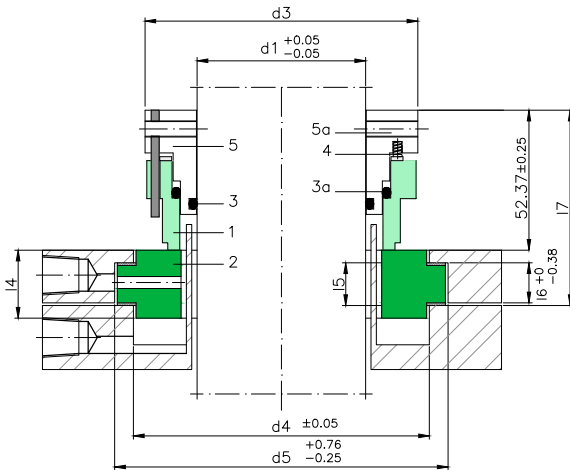

SECTORS:



CHARACTERISTICS:

- **Balanced.**
- System attached to the shaft by allen screws.
- **Not dependent on the rotation direction.**
- External mounting.

OPERATING LIMITS:

$d_1 = 25 \div 175 \text{ mm}$ $p = 15 \text{ kg/cm}^2$
 $v = 2 \text{ m/s}$ $t = -20 \div +200^\circ\text{C} (*)$

(*) The temperature resistance depends on the material of the secondary seals used.

The operating limits are defined by the PV factor which is determined for the sealing system characteristics and those of the application.

DESCRIPTION:

It can be used in vertical agitators with moderate speeds without the need to apply auxiliary lubrication systems. Adapted to DEBRIS cleaning systems.

DIMENSIONS CHART

Dimensions in mm

Shaft mm	Rotary part d_3	Stationary part						
		d_4	d_5	l_4	l_5	l_6	l_7	
25	63,5	47,6	57,9	20,6	12,7	11,9	69,0	
28	66,6	50,8	61,1	20,6	12,7	11,9	69,0	
30	69,8	53,9	67,5	22,2	12,7	11,9	69,0	
32	69,8	53,9	67,5	22,2	12,7	11,9	69,0	
33	73,0	57,1	70,6	22,2	12,7	11,9	69,0	
35	73,0	57,1	70,6	22,2	12,7	11,9	69,0	
38	76,2	63,5	77,0	22,2	12,7	11,9	69,0	
40	79,3	66,6	80,2	22,2	12,7	11,9	69,0	
43	82,5	69,8	83,3	22,2	12,7	11,9	69,0	
45	85,7	73,0	89,7	25,4	15,9	15,1	73,0	
50	88,9	79,3	96,0	25,4	15,9	15,1	73,0	
53	92,0	79,3	99,2	25,4	15,9	15,1	73,0	
55	95,2	85,7	102,4	25,4	15,9	15,1	73,0	
58	98,4	88,9	105,6	25,4	15,9	15,1	73,0	
60	98,4	88,9	105,6	25,4	15,9	15,1	73,0	
63	101,6	92,0	108,7	25,4	15,9	15,1	73,0	
65	104,7	95,2	111,9	25,4	15,9	15,1	73,0	
68	107,9	98,4	115,1	25,4	15,9	15,1	73,0	
70	107,9	98,4	115,1	25,4	15,9	15,1	73,0	
75	114,3	103,3	119,8	25,4	15,9	15,1	73,0	
80	120,6	111,1	127,8	25,4	15,9	15,1	73,0	
85	123,9	114,3	131,1	25,4	15,9	15,1	73,0	
90	130,2	120,7	137,3	25,4	15,9	15,1	73,0	
95	133,3	123,8	140,5	25,4	15,9	15,1	73,0	
100	139,7	133,3	150,0	25,4	15,9	15,1	73,0	
105	142,9	136,5	153,2	25,4	15,9	15,1	73,0	
110	149,2	142,8	159,5	25,4	15,9	15,1	73,0	
115	155,5	149,2	165,9	25,4	15,9	15,1	73,0	

Dimensions in inches

Shaft (")	Rotary part mm	d_3	Stationary part						
			d_4	d_5	l_4	l_5	l_6	l_7	
1.00	25.40	63.50	47.63	57.94	20.62	12.70	11.89	69.04	
1.13	28.58	66.68	50.80	61.11	20.62	12.70	11.89	69.04	
1.25	31.75	69.85	53.98	67.46	20.62	12.70	11.89	69.85	
1.38	34.93	73.03	57.15	70.64	20.62	12.70	11.89	69.85	
1.50	38.10	76.20	63.50	76.99	20.62	12.70	11.89	69.85	
1.63	41.28	79.38	66.68	80.16	20.62	12.70	11.89	69.85	
1.75	44.45	82.55	69.85	83.34	20.62	12.70	11.89	73.03	
1.88	47.63	85.73	73.03	89.69	25.40	15.88	11.89	73.03	
2.00	50.80	88.90	79.38	98.32	25.40	15.88	11.89	73.03	
2.13	53.98	92.08	79.38	99.21	25.40	15.88	15.06	73.03	
2.25	57.15	95.25	85.73	102.39	25.40	15.88	15.06	73.03	
2.38	60.33	98.43	88.90	105.56	25.40	15.88	15.06	73.03	
2.50	63.50	101.60	92.08	108.74	25.40	15.88	15.06	73.03	
2.63	66.68	104.78	95.25	111.91	25.40	15.88	15.06	73.03	
2.75	69.85	107.95	98.43	115.09	25.40	15.88	15.06	73.03	
2.88	73.03	111.13	101.60	118.26	25.40	15.88	15.06	73.03	
3.00	76.20	114.30	104.78	119.84	25.40	15.88	15.06	73.03	
3.13	79.38	117.48	107.95	124.61	25.40	15.88	15.06	73.03	
3.25	82.55	120.65	111.13	127.79	25.40	15.88	15.06	73.03	
3.38	85.73	123.83	114.30	130.96	25.40	15.88	15.06	73.03	
3.50	88.90	127.00	117.48	134.14	25.40	15.88	15.06	73.03	
3.63	92.08	130.18	120.65	137.31	25.40	15.88	15.06	73.03	
3.75	95.25	133.35	123.83	140.49	25.40	15.88	15.06	73.03	
3.88	98.43	136.53	127.00	143.66	25.40	15.88	15.06	73.03	
4.00	101.60	139.70	130.18	150.01	25.40	15.88	15.06	73.03	
4.13	104.78	142.88	133.35	153.19	25.40	15.88	15.06	73.03	
4.25	107.95	146.05	136.53	156.36	25.40	15.88	15.06	73.03	
4.38	111.13	149.23	139.70	159.54	25.40	15.88	15.06	73.03	
4.50	114.30	152.40	142.88	162.71	25.40	15.88	15.06	73.03	

Dimensions subject to changes or modifications.

LMS29



COMPONENTS:

- 1 Rotating contact surface
- 2 Stationary contact surface
- 3a O-rings
- 3b O-rings
- 3c O-rings
- 3d O-rings
- 4 Springs
- 5 Metal frame
- 5a Set screws

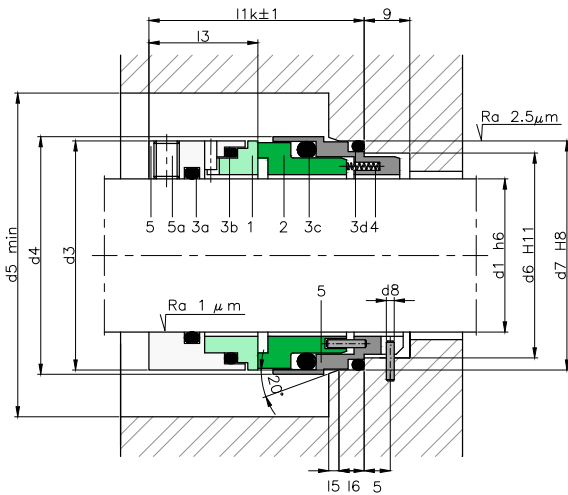

SECTORS:



CHARACTERISTICS:

- **Balanced.**
- System attached to the shaft by allen screws
- **Not dependent on the rotation direction.**

OPERATING LIMITS:

$d_1 = 18 \div 100 \text{ mm}$ $p = 25 \text{ kg/cm}^2$
 $v = 20 \text{ m/s}$ $t = -15 \div +200^\circ\text{C} (*)$

(*) The temperature resistance depends on the material of the secondary seals used.

The operating limits are defined by the PV factor which is determined for the sealing system characteristics and those of the application.

DESCRIPTION:

The fact that the springs are not in contact with the fluid makes this mechanical seal perfect for working with particle-laden fluids, as it prevents them from becoming blocked or obstructed.

Its structure and design makes it ideal for vacuum operations without having to use a retaining ring. It can be used with a single, tandem-mounted (API52) or back-to back (API53) mounting system. The O-ring resting on the shaft is not affected by any axial movement (changes in pressure) and therefore produces no wear on the surface of the shaft. Seal compliant with standard EN 12756 (KU).

DIMENSIONS CHART

Dimensions in mm

Shaft mm	Rotary part				Stationary part					Total length
	d ₃	d ₄	l ₃	d ₅	d ₆	d ₇	d ₈	l ₅	l ₆	
18	33	34.7	19.5	39.7	27	33	3	2.0	5	37.5
20	35	36.7	19.5	41.7	29	35	3	2.0	5	37.5
22	37	38.7	19.5	43.7	31	37	3	2.0	5	37.5
24	39	40.7	20.5	45.7	33	39	3	2.0	5	40.0
25	40	41.7	20.5	46.7	34	40	3	2.0	5	40.0
28	43	44.7	21.5	49.7	37	43	3	2.0	5	42.5
30	45	46.7	21.5	51.7	39	45	3	2.0	5	42.5
32	48	49.7	21.5	54.7	42	48	3	2.0	5	42.5
33	48	49.7	21.5	54.7	42	48	3	2.0	5	42.5
35	50	51.7	21.5	56.7	44	50	3	2.0	5	42.5
38	56	57.7	24.0	62.7	49	56	4	2.0	5	45.0
40	58	59.7	24.0	64.7	51	58	4	2.0	5	45.0
43	61	62.7	24.0	67.7	54	61	4	2.0	5	45.0
45	63	64.7	24.0	69.7	56	63	4	2.0	5	45.0
48	66	67.7	24.0	72.7	59	66	4	2.0	5	45.0
50	70	71.7	25.0	76.7	62	70	4	2.5	6	47.5
53	73	74.7	25.0	79.7	65	73	4	2.5	6	47.5
55	75	76.7	25.0	81.7	67	75	4	2.5	6	47.5
58	78	80.5	28.0	85.5	70	78	4	2.5	6	52.5
60	80	82.5	28.0	87.5	72	80	4	2.5	6	52.5
63	83	85.5	28.0	90.5	75	83	4	2.5	6	52.5
65	85	87.5	28.0	92.5	77	85	4	2.5	6	52.5
68	90	92.5	28.0	97.5	81	90	4	2.5	7	52.5
70	92	94.5	34.0	99.5	83	92	4	2.5	7	60.0
75	97	100.5	34.0	105.5	88	97	4	2.5	7	60.0
80	105	108.5	34.0	113.5	95	105	4	3.0	7	60.0
85	110	113.5	34.0	118.5	100	110	4	3.0	7	60.0
90	115	118.5	39.0	123.5	105	115	4	3.0	7	65.0
95	120	123.5	39.0	128.5	110	120	4	3.0	7	65.0
100	125	128.5	39.0	133.5	115	125	4	3.0	7	65.0

Dimensions subject to changes or modifications.

LWS10



COMPONENTS:

- 1 Rotating contact surface
- 2 Stationary contact surface
- 3 O-rings
- 3a O-rings
- 4 Spring
- 5 Metal frame
- 5a Set screws
- 5b Ring

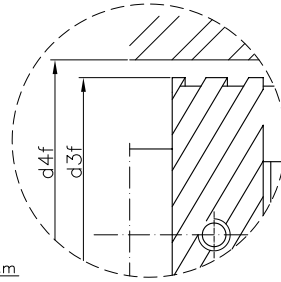
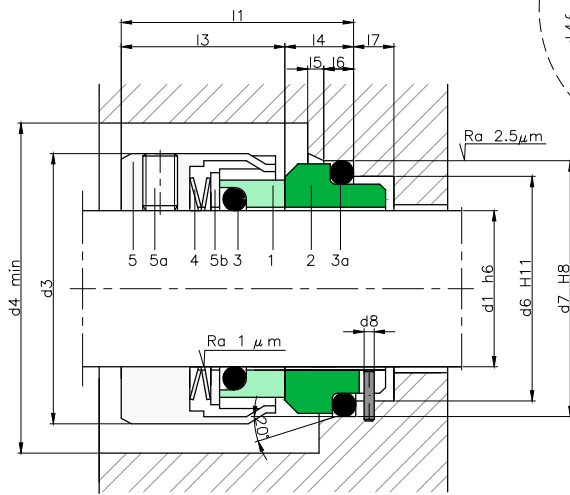

Tolerance: l₁, d₃ 14...25 mm ± 1.0; 28...63 mm ± 1.5; > 65 mm ± 2.0

SECTORS:



CHARACTERISTICS:

- Unbalanced.
- System attached to the shaft by allen screws.
- Not dependent on the rotation direction.

OPERATING LIMITS:

$d_i = 14 \div 150 \text{ mm}$ $p = 10 \text{ kg/cm}^2$
 $v = 20 \text{ m/s}$ $t = -15 \div +200^\circ\text{C} (*)$

(*) The temperature resistance depends on the material of the secondary seals used.

The operating limits are defined by the PV factor which is determined for the sealing system characteristics and those of the application.

DESCRIPTION:

Recommended for working with sticky fluids and fluids laden with particles and fibres. Unlike the multispring models, the wave spring model cannot be blocked or obstructed and its open leaf design produces a self-cleaning effect. Standard L9 type stationary part. Seal compliant with standard EN 12756 (KU). Available with a pumping ring on the casing to reduce the temperature between the contact surfaces and facilitate the barrier fluid movement in the case of double mounting (reference LWS10-F). Contact surface kits supplied available.

DIMENSIONS CHART

Dimensions in mm

Shaft mm	Rotary part					Stationary part							Total length l ₁
	d ₃	d _{3f}	d _{4f}	d ₄	l ₃	d ₆	d ₇	d ₈	l ₄	l ₅	l ₆	l ₇	
14	25	34	39	30	25.0	21	25	3	10.0	1.5	4	8.5	35.0
16	27	36	41	32	25.0	23	27	3	10.0	1.5	4	8.5	35.0
18	33	38	43	38	26.0	27	33	3	11.5	2.0	4	9.0	37.5
20	35	40	45	40	26.0	29	35	3	11.5	2.0	5	9.0	37.5
22	37	42	47	42	26.0	31	37	3	11.5	2.0	5	9.0	37.5
24	39	44	49	44	28.5	33	39	3	11.5	2.0	5	9.0	40.0
25	40	45	50	45	28.5	34	40	3	11.5	2.0	5	9.0	40.0
28	43	47	52	48	31.0	37	43	3	11.5	2.0	5	9.0	42.5
30	45	49	54	50	31.0	39	45	3	11.5	2.0	5	9.0	42.5
32	47	51	56	52	31.0	42	48	3	11.5	2.0	5	9.0	42.5
33	48	51	56	53	31.0	42	48	3	11.5	2.0	5	9.0	42.5
35	50	54	59	55	31.0	44	50	3	11.5	2.0	5	9.0	42.5
38	55	59	64	60	31.0	49	56	4	14.0	2.0	6	9.0	45.0
40	57	61	66	62	31.0	51	58	4	14.0	2.0	6	9.0	45.0
43	60	65	70	65	31.0	54	61	4	14.0	2.0	6	9.0	45.0
45	62	66	71	67	31.0	56	63	4	14.0	2.0	6	9.0	45.0
48	65	69	74	70	31.0	59	66	4	14.0	2.0	6	9.0	45.0
50	67	71	76	72	32.5	62	70	4	15.0	2.5	6	9.0	47.5
53	70	75	80	75	32.5	65	73	4	15.0	2.5	6	9.0	47.5
55	72	76	81	77	32.5	67	75	4	15.0	2.5	6	9.0	47.5
58	79	83	88	84	37.5	70	78	4	15.0	2.5	6	9.0	52.5
60	81	85	90	86	37.5	72	80	4	15.0	2.5	6	9.0	52.5
63	84	88	93	89	37.5	75	83	4	15.0	2.5	6	9.0	52.5
65	86	95	100	91	37.5	77	85	4	15.0	2.5	6	9.0	52.5
68	89	93	98	94	34.5	81	90	4	18.0	2.5	7	9.0	52.5
70	91	95	100	96	42.0	83	92	4	18.0	2.5	7	9.0	60.0
75	99	105	110	104	42.0	88	97	4	18.0	2.5	7	9.0	60.0
80	104	109	114	109	41.8	95	105	4	18.2	3.0	7	9.0	60.0
85	109	114	119	114	41.8	100	110	4	18.2	3.0	7	9.0	60.0
90	114	119	124	119	46.8	105	115	4	18.2	3.0	7	9.0	65.0
95	119	124	129	124	47.8	110	120	4	17.2	3.0	7	9.0	65.0
100	124	129	134	129	47.8	115	125	4	17.2	3.0	7	9.0	65.0

Shaft mm	Rotary part			Stationary part							Total length l ₁
	d ₃	d ₄	l ₃	d ₆	d ₇	d ₈	l ₄	l ₅	l ₆	l ₇	
105	138	143	47	122.2	134.3	5	20	2	10	--	67
110	143	148	47	128.2	140.3	5	20	2	10	--	67
115	148	153	47	136.2	148.3	5	20	2	10	--	67
120	153	158	47	138.2	150.3	5	20	2	10	--	67
125	158	163	47	142.2	154.3	5	20	2	10	--	67
130	163	168	47	146.2	158.3	5	20	2	10	--	67
135	168	173	47	152.2	164.3	5	20	2	10	--	67
140	173	178	47	156.2	168.3	5	20	2	10	--	67
145	178	183	47	161.2	173.3	5	20	2	10	--	67
150	183	189	47	168.2	180.3	5	22	2	10	--	69

* Multispring design manufacture for d₁>100 mm.

Dimensions subject to changes or modifications.

LWS10B



COMPONENTS:

- 1 Rotating contact surface
- 2 Stationary contact surface
- 3 O-rings
- 3a O-rings
- 4 Spring
- 5 Metal frame
- 5a Set screws
- 5b Ring

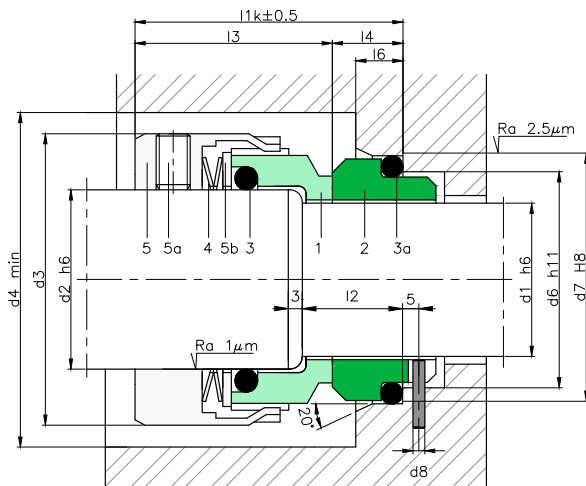

SECTORS:



CHARACTERISTICS:

- **Balanced.**
- System attached to the shaft by allen screws.
- **Not dependent on the rotation direction.**

OPERATING LIMITS:

$d_i = 14 \div 100 \text{ mm}$ $p = 25 \text{ kg/cm}^2$
 $v = 20 \text{ m/s}$ $t = -50 \div +220^\circ\text{C} (*)$

(*) The temperature resistance depends on the material of the secondary seals used.

The operating limits are defined by the PV factor which is determined for the sealing system characteristics and those of the application.

DESCRIPTION:

The balanced contact surface design allows the mechanical seal to be used in applications with high pressures without suffering premature wear. Recommended for working with sticky fluids and fluids laden with particles and fibres. Unlike the multispring models, the wave spring model cannot be blocked or obstructed and its open leaf design produces a self-cleaning effect. Standard L9 type fixed stationary part, standardised seal, compliant with EN 12756 (KB).

The casing can incorporate a pumping ring to reduce the temperature between the contact surfaces and facilitate the barrier fluid movement in the case of double mounting (reference LWS10B-F).

DIMENSIONS CHART

Dimensions in mm

Shaft		Rotary part			Stationary part						Total length
d ₁	d ₂	d ₃	d ₄	l ₃	d ₆	d ₇	d ₈	l ₂	l ₄	l ₆	l _{1k}
14	18	33	37	32.5	21	25	3	18	10.0	9	42.5
16	20	35	39	32.5	23	27	3	18	10.0	9	42.5
18	22	37	41	33.5	27	33	3	20	11.5	9	45.0
20	24	39	43	33.5	29	35	3	20	11.5	9	45.0
22	26	41	45	33.5	31	37	3	20	11.5	9	45.0
24	28	43	47	36.0	33	39	3	20	11.5	9	47.5
25	30	45	49	36.0	34	40	3	20	11.5	9	47.5
28	33	48	52	38.5	37	43	3	20	11.5	9	50.0
30	35	50	54	38.5	39	45	3	20	11.5	9	50.0
32	38	55	59	38.5	42	48	3	20	11.5	9	50.0
33	38	55	59	38.5	42	48	3	20	11.5	9	50.0
35	40	57	61	38.5	44	50	3	20	11.5	9	50.0
38	43	60	64	38.5	49	56	4	23	14.0	10	52.5
40	45	62	66	38.5	51	58	4	23	14.0	10	52.5
43	48	65	69	38.5	54	61	4	23	14.0	10	52.5
45	50	67	71	38.5	56	63	4	23	14.0	10	52.5
48	53	70	74	38.5	59	66	4	23	14.0	10	52.5
50	55	72	76	42.5	62	70	4	25	15.0	11	57.5
53	58	79	83	42.5	65	73	4	25	15.0	11	57.5
55	60	81	85	42.5	67	75	4	25	15.0	11	57.5
58	63	84	88	47.5	70	78	4	25	15.0	11	62.5
60	65	86	90	47.5	72	80	4	25	15.0	11	62.5
63	68	89	93	47.5	77	83	4	25	15.0	11	62.5
65	70	91	95	47.5	75	85	4	25	15.0	11	62.5
70	75	99	103	52.0	83	92	4	28	18.0	12	70.0
75	80	104	108	52.0	88	97	4	28	18.0	12	70.0
80	85	109	113	51.8	95	105	4	28	18.2	13	70.0
85	90	114	118	56.8	100	110	4	28	18.2	13	75.0
90	95	119	123	56.8	105	115	4	28	18.2	13	75.0
95	100	124	128	57.8	110	120	4	28	17.2	13	75.0
100	105	129	133	57.8	115	125	4	28	17.2	13	75.0

Dimensions subject to changes or modifications.

LWS12



COMPONENTS:

- 1 Rotating contact surface
- 2 Stationary contact surface
- 3 O-rings
- 3a O-rings
- 4 Spring
- 5 Set screws
- 5a Metal frame

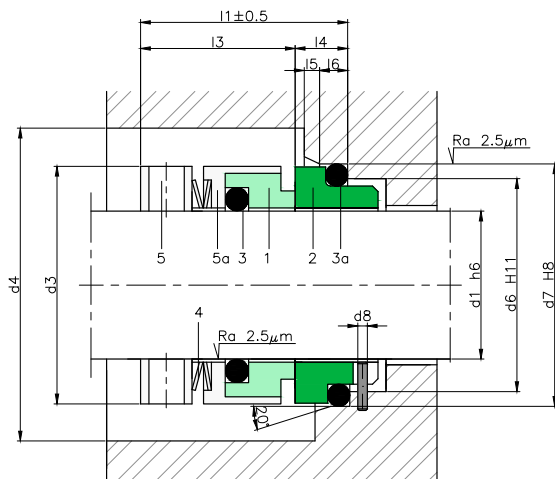

SECTORS:



CHARACTERISTICS:

- Unbalanced.
- System attached to the shaft by allen screws.
- Not dependent on the rotation direction.

OPERATING LIMITS:

$d_i = 20 \div 100 \text{ mm}$ $p = 10 \text{ kg/cm}^2$
 $v = 20 \text{ m/s}$ $t = -15 \div +200^\circ\text{C}$ (*)

(*) The temperature resistance depends on the material of the secondary seals used.

The operating limits are defined by the PV factor which is determined for the sealing system characteristics and those of the application.

DESCRIPTION:

Its mounting dimensions make it a perfect seal for installing in small spaces. The wave spring is not blocked or obstructed when working with fluids laden with particles and fibres, or viscous fluids. Standard L1 DIN stationary part.

DIMENSIONS CHART

Dimensions in mm

Shaft mm	Rotary part			Stationary part						Total length l_1
	d_3	d_4	l_3	d_6	d_7	d_8	l_4	l_5	l_6	
20	31	36	20.5	29	35	3	10.0	2.0	5	30.5
22	33	38	20.5	31	37	3	10.0	2.0	5	30.5
24	36	41	22.5	33	39	3	10.0	2.0	5	32.5
25	39	44	23.5	34	40	3	10.0	2.0	5	33.5
28	42	47	23.5	37	43	3	10.0	2.0	5	33.5
30	44	49	24.5	39	45	3	10.0	2.0	5	34.5
32	46	51	24.5	42	48	3	10.0	2.0	5	34.5
33	47	52	24.5	42	48	3	10.0	2.0	5	34.5
35	49	54	24.5	44	50	3	10.0	2.0	5	34.5
38	53	58	27.0	49	56	4	11.0	2.0	6	38.0
40	55	60	28.0	51	58	4	11.0	2.0	6	39.0
43	58	63	28.0	54	61	4	11.0	2.0	6	39.0
45	60	65	28.0	56	63	4	11.0	2.0	6	39.0
48	63	68	28.0	59	66	4	11.0	2.0	6	39.0
50	66	71	27.0	62	70	4	13.0	2.5	6	39.0
53	69	74	27.0	65	73	4	13.0	2.5	6	39.0
55	71	76	27.0	67	75	4	13.0	2.5	6	39.0
58	77	82	29.0	70	78	4	13.0	2.5	6	42.0
60	79	84	29.0	72	80	4	13.0	2.5	6	42.0
63	82	87	32.0	75	83	4	13.0	2.5	6	45.0
65	84	89	32.0	77	85	4	13.0	2.5	6	45.0
68	87	92	33.5	81	90	4	15.0	2.5	7	48.5
70	89	94	32.0	83	92	4	15.0	2.5	7	47.0
75	94	99	32.0	88	97	4	15.0	2.5	7	47.0
80	100	105	32.5	95	105	4	15.5	3.0	7	48.0
85	105	110	32.5	100	110	4	15.5	3.0	7	48.0
90	112	117	38.5	105	115	4	15.5	3.0	7	54.0
95	117	122	38.5	110	120	4	15.5	3.0	7	54.0
100	122	127	38.5	115	125	4	15.5	3.0	7	54.0

Dimensions subject to changes or modifications.

LWS30 / LWS30A



COMPONENTS:

- 1 Rotating contact surface
- 2 Stationary contact surface
- 3a O-rings
- 3b O-rings
- 3c O-rings
- 4 Spring
- 5 Metal frame
- 5a Set screws

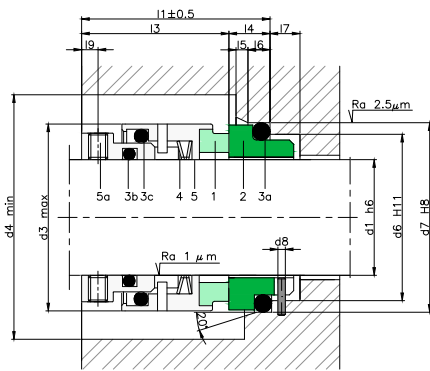

TYPE LWS30

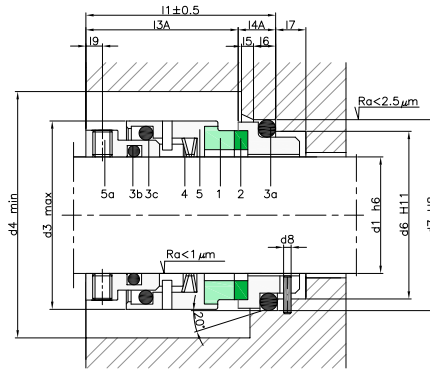

TYPE LWS30A

SECTORS:



CHARACTERISTICS:

- **Balanced.**
- System attached to the shaft by allen screws.
- **Not dependent on the rotation direction.**

OPERATING LIMITS:

$d_1 = 18 \div 100 \text{ mm}$ $p = 35 \text{ kg/cm}^2$
 $v = 20 \text{ m/s}$ $t = -15 \div +200^\circ\text{C}$ (*)

(*) The temperature resistance depends on the material of the secondary seals used.

The operating limits are defined by the PV factor which is determined for the sealing system characteristics and those of the application.

DESCRIPTION:

The wave spring is protected from the fluid. Ideal for using in cleaning processes since the possibility of particles adhering to the seal is considerably reduced.

Internally balanced, with no need for a stepped shaft (LWS10B). Suitable for working in applications with high pressures. The O-ring resting on the shaft does not cause wear as there is no axial movement (changes in pressure).

Seal compliant with standard EN 12756 (KU). Standard L16 type stationary part (LWS30).

DIMENSIONS CHART

Dimensions in mm

Shaft mm	Rotary part					Stationary part							Total length	
	d ₃	d ₄	l ₃	l _{3A}	l ₉	d ₆	d ₇	d ₈	l ₄	l _{4A}	l ₅	l ₆		l ₇
18	32	34	30.5	28.5	3.0	27	33	3	7.0	9.0	2.0	4	8.5	37.5
20	34	36	30.5	28.5	3.0	29	35	3	7.0	9.0	2.0	5	8.5	37.5
22	36	38	30.5	28.5	3.0	31	37	3	7.0	9.0	2.0	5	9.0	37.5
24	38	40	33.0	31.0	3.5	33	39	3	7.0	9.0	2.0	5	9.0	40.0
25	39	41	33.0	31.0	3.5	34	40	3	7.0	9.0	2.0	5	9.0	40.0
28	42	44	35.5	33.0	3.5	37	43	3	7.0	9.5	2.0	5	9.0	42.5
30	44	46	35.5	33.0	3.5	39	45	3	7.0	9.5	2.0	5	9.0	42.5
32	47	48	35.5	33.0	3.5	42	48	3	7.0	9.5	2.0	5	9.0	42.5
33	47	49	35.5	33.0	3.5	42	48	3	7.0	9.5	2.0	5	9.0	42.5
35	49	51	35.5	33.0	3.5	44	50	3	7.0	9.5	2.0	5	9.0	42.5
38	54	58	37.0	34.5	4.0	49	56	4	8.0	10.5	2.0	6	9.0	45.0
40	56	60	37.0	34.5	4.0	51	58	4	8.0	10.5	2.0	6	9.0	45.0
43	59	63	37.0	34.5	4.0	54	61	4	8.0	10.5	2.0	6	9.0	45.0
45	61	65	37.0	34.5	4.0	56	63	4	8.0	10.5	2.0	6	9.0	45.0
48	64	68	37.0	34.5	4.0	59	66	4	8.0	10.5	2.0	6	9.0	45.0
50	66	70	38.0	35.5	4.5	62	70	4	9.5	12.0	2.5	6	9.0	47.5
53	69	73	38.0	35.5	4.5	65	73	4	9.5	12.0	2.5	6	9.0	47.5
55	71	75	38.0	35.5	4.5	67	75	4	9.5	12.0	2.5	6	9.0	47.5
58	78	83	42.0	39.5	4.5	70	78	4	10.5	13.0	2.5	6	9.0	52.5
60	80	85	42.0	39.5	4.5	72	80	4	10.5	13.0	2.5	6	9.0	52.5
63	83	88	42.0	39.5	4.5	75	83	4	10.5	13.0	2.5	6	9.0	52.5
65	85	90	42.0	39.5	4.5	77	85	4	10.5	13.0	2.5	6	9.0	52.5
68	88	93	41.5	39.0	4.5	81	90	4	11.0	13.5	2.5	7	9.0	52.5
70	90	95	48.5	46.0	5.0	83	92	4	11.5	14.0	2.5	7	9.0	60.0
75	99	104	48.5	46.0	5.5	88	97	4	11.5	14.0	2.5	7	9.0	60.0
80	104	109	48.5	46.0	5.5	95	105	4	11.5	14.0	3.0	7	9.0	60.0
85	109	114	48.5	46.0	5.5	100	110	4	11.5	14.0	3.0	7	9.0	60.0
90	114	119	52.0	49.5	5.5	105	115	4	13.0	15.5	3.0	7	9.0	65.0
95	119	124	52.0	49.5	5.5	110	120	4	13.0	15.5	3.0	7	9.0	65.0
100	124	129	52.0	49.5	5.5	115	125	4	13.0	15.5	3.0	7	9.0	65.0

Dimensions subject to changes or modifications.

LWS31



COMPONENTS:

- 1 Rotating contact surface
- 2 Stationary contact surface
- 3a O-rings
- 3b O-rings
- 3c Elastomeric cup
- 3d Elastomeric cup
- 4 Springs
- 5 Metal frame

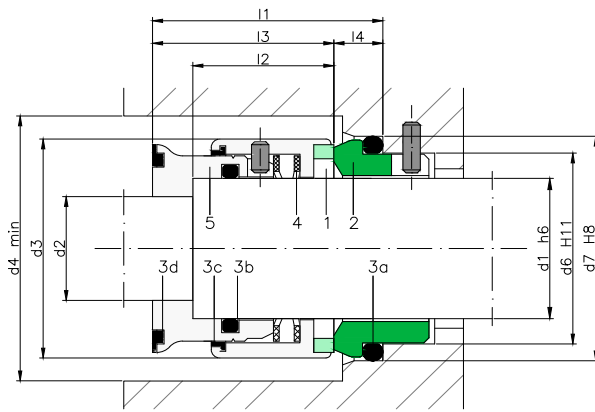

SECTORS:



CHARACTERISTICS:

- **Balanced.**
- Shaft fixing system **WITHOUT** screws.
- **Sentido rotación independiente.**

OPERATING LIMITS:

$d_1 = 20 \div 35 \text{ mm}$ $p = 35 \text{ kg/cm}^2$

$v = 20 \text{ m/s}$ $t = -40 \div +150^\circ\text{C} (*)$

(*) The temperature resistance depends on the material of the secondary seals used.

The operating limits are defined by the PV factor which is determined for the sealing system characteristics and those of the application.

DESCRIPTION:

A wave spring mechanical seal in which the spring is isolated and protected from the product. Its hygienic design reduces the likelihood of traces of product being deposited on its surface, thereby eliminating the risk of contamination.

DIMENSIONS CHART

Dimension in mm

Shaft mm	Rotary part					Stationary part			Total length l ₁
	d ₂	d ₃	l ₄	l ₂	l ₃	d ₆	d ₇	l ₄	
20	13.5	34	39	23	29	29	35	8.5	37.5
25	18.5	39	44	24.5	31.5	34	40	8.5	40
35	22.5	49	54	26	34	44	50	8.5	42.5
40	26	56	61	27.5	34.5	51	58	10.5	45

Dimensions subject to changes or modifications.

LWS70 / LWS71



COMPONENTS:

- 1 Rotating contact surface
- 2 Stationary contact surface
- 3 O-rings
- 3a O-rings
- 4 Spring
- 5 Metal frame
- 5a Set screws
- 5b Coupling pin

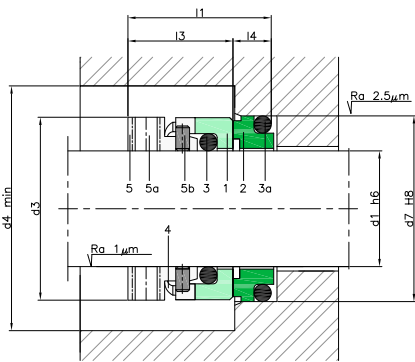

TYPE LWS70

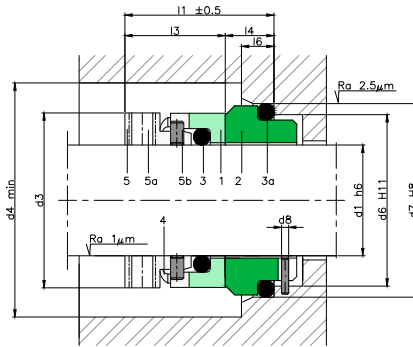

TYPE LWS71

SECTORS:



CHARACTERISTICS:

- Unbalanced.
- System attached to the shaft by Allen screws.
- Not dependent on the rotation direction.

OPERATING LIMITS:

$d_1 = 15.8 \div 100 \text{ mm}$ $p = 10 \text{ kg/cm}^2$
 $v = 15 \text{ m/s}$ $t = -15 \div +200^\circ\text{C}$ (*)

(*) The temperature resistance depends on the material of the secondary seals used.

The operating limits are defined by the PV factor which is determined for the sealing system characteristics and those of the application.

DESCRIPTION:

This mechanical seal is designed for internal and external mounting. Its small mounting size makes it ideal for using in lobe pumps. The wave spring cannot be blocked or obstructed when working with fluids laden with particles, sticky or viscous fluids. The fact that the rotating part of the mechanical seal is made of stainless steel (the most habitual combination) makes it a resistant, robust seal.

DIMENSIONS CHART

Dimensions in mm

(mm)	d ₃	d ₄	l ₃	LWS70			LWS71							
				d ₇	l ₄	l ₁	d ₆	d ₇	d ₈	l ₄	l ₆	l ₁		
15,8	27	30	19,1	28,5	6,3	25,4	-	-	-	-	-	-	-	-
16	27	31	19,1	28,5	6,3	25,4	21	27	3	8,6	7	27,7	-	-
18	29	33	19,1	-	-	-	27	33	3	10	9	29,1	-	-
19,1	30	33	19,1	31,7	6,3	25,4	-	-	-	-	-	-	-	-
20	32	36	19,1	-	-	-	29	35	3	10	9	29,1	-	-
22	34	38	19,1	-	-	-	31	37	3	10	9	29,1	-	-
24	34	38	19,1	35,4	7,6	26,7	33	39	3	10	9	29,1	-	-
25	35	39	19,1	-	-	-	34	40	3	10	9	29,1	-	-
28	40	44	19,1	42	7,6	26,7	37	43	3	10	9	29,1	-	-
28,6	39,5	42,5	19,1	41,2	7,6	26,7	-	-	-	-	-	-	-	-
30	41	45	19,1	42,7	7,6	26,7	39	45	3	10	9	29,1	-	-
31,7	42,4	45,4	19,1	44,2	7,6	26,7	-	-	-	-	-	-	-	-
32	43	47	19,1	44,4	7,6	26,7	42	48	3	10	9	29,1	-	-
33	44	48	19,1	-	-	-	42	48	3	10	9	29,1	-	-
35	46	50	19,1	47,6	7,6	26,7	44	50	3	10	9	29,1	-	-
38	52	56	21,1	53,9	8,1	29,2	49	56	4	11	10	32,1	-	-
40	55	59	21,1	-	-	-	51	58	4	11	10	32,1	-	-
43	58	62	21,1	-	-	-	54	61	4	11	10	32,1	-	-
44,4	58,2	61,2	21,1	60,3	8,1	29,2	-	-	-	-	-	-	-	-
45	60	64	21,1	-	-	-	56	63	4	11	10	32,1	-	-
47,6	61,4	64,4	21,1	63,5	8,1	29,2	-	-	-	-	-	-	-	-
48	62	66	21,1	-	-	-	59	66	4	11	10	32,1	-	-
50	62	66	21,1	63,9	8,1	29,2	62	70	4	13	11	34,1	-	-
50,8	64,6	67,6	22,1	66,6	9,6	31,7	-	-	-	-	-	-	-	-
53	71	75	22,1	-	-	-	65	73	4	13	11	35,1	-	-
53,9	71	74	22,1	73	9,6	31,7	-	-	-	-	-	-	-	-
54	71	74	22,1	73,9	9,6	31,7	-	-	-	-	-	-	-	-
54,6	72	75	22,1	75	9,6	31,7	-	-	-	-	-	-	-	-
55	72	76	22,1	75	9,6	31,7	67	75	4	13	11	35,1	-	-
58	78	82	25,8	-	-	-	70	78	4	13	11	38,8	-	-
60	79	83	25,8	-	-	-	72	80	4	13	11	38,8	-	-
63	79,3	82,3	25,8	83	9,1	34,9	75	83	4	13	11	38,8	-	-
63,5	79,3	82,3	25,8	88,9	9,1	34,9	-	-	-	-	-	-	-	-
65	87	91	25,8	-	-	-	77	85	4	13	11	38,8	-	-
68	89	93	25,8	-	-	-	81	90	4	15,3	12	41,1	-	-
69,8	88,9	91,9	25,8	95,2	9,1	34,9	-	-	-	-	-	-	-	-
70	89	93	25,8	-	-	-	83	92	4	15,3	12	41,1	-	-
73	94	97	25,8	98,4	9,1	34,9	-	-	-	-	-	-	-	-
75	96	100	25,8	100,4	9,1	34,9	88	97	4	15,3	12	41,1	-	-
76,2	96,9	99,9	25,8	101,6	9,1	34,9	-	-	-	-	-	-	-	-
80	101	105	25,8	104	9,1	34,9	95	105	4	15,7	13	41,5	-	-
85	108	112	25,8	-	-	-	100	110	4	15,7	13	41,5	-	-
90	113	117	25,8	-	-	-	105	115	4	15,7	13	41,5	-	-
95	116	120	25,8	125	9,1	34,9	110	120	4	15,7	13	41,5	-	-
100	121	125	25,8	130	9,1	34,9	115	125	4	15,7	13	41,5	-	-

Dimensions subject to changes or modifications.

FH / FHC



COMPONENTS:

- 1 Rotating contact surface
- 2 Stationary contact surface
- 3 O-rings
- 3a O-rings
- 3b O-rings
- 3T PTFE wedge
- 3Ta PTFE gasket
- 4 Spring
- 5 Metal frame

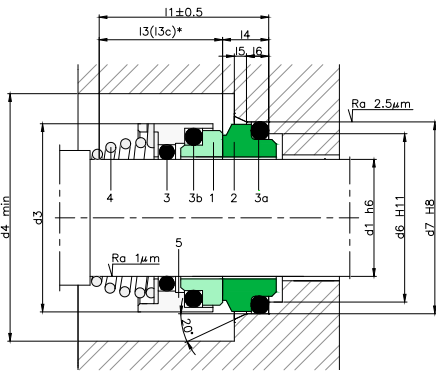

TYPE FH

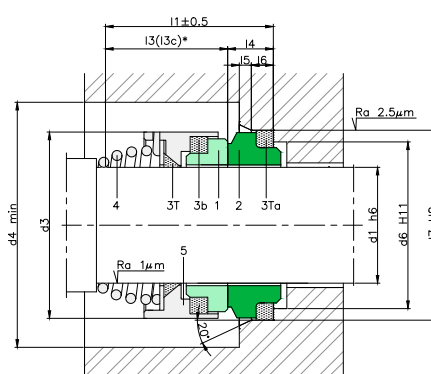

TYPE FH PTFE

SECTORS:



CHARACTERISTICS:

- Unbalanced.
- Single conical spring.
- Dependent on the rotation direction.
- Exchangeable contact surfaces.

OPERATING LIMITS:

$d_1 = 10 \div 100 \text{ mm}$ $p = 10 \text{ kg/cm}^2$
 $v = 20 \text{ m/s}$ $t = -20 \div +200^\circ\text{C}$ (*)

(*) The temperature resistance depends on the material of the secondary seals used.

The operating limits are defined by the PV factor which is determined for the sealing system characteristics and those of the application.

DESCRIPTION:

A general-purpose single, robust seal in which the contact surfaces can be exchanged with each other. It can be used in industrial applications for clean fluids with low viscosities or with a low content of suspended solids that tend to produced sediments or adhere to the seal.

Types:

FH6: secondary seals made of PTFE.

FHC: same structure as FH but the length is I3C.

DIMENSIONS CHART

Dimensions in mm

Shaft mm	Rotary part				Stationary part						Total length l ₁
	d ₃	d ₄	l ₃	l _{3c*}	d ₆	d ₇	l ₄	l ₅	l ₆		
10	20	22	20	15	14.0	18.1	5.5	1.2	3	25.5	
12	22	25	22	18	16.5	20.6	5.5	1.2	3	27.5	
14	25	28	27	22	19.0	23.1	6.0	1.2	3	33.0	
15	29	32	27	22	21.0	26.9	7.0	1.5	4	34.0	
16	29	32	28	23	21.0	26.9	7.0	1.5	4	35.0	
18	33	36	30	24	25.0	30.9	8.0	1.5	4	38.0	
20	33	36	30	25	25.0	30.9	8.0	1.5	4	38.0	
22	38	41	30	25	30.0	35.4	8.0	2.0	4	38.0	
24	38	41	32	27	30.0	35.4	8.0	2.0	4	40.0	
25	40	45	33	27	33.0	38.2	8.5	2.0	4	41.5	
26	40	45	33	27	33.0	38.2	8.5	2.0	4	41.5	
28	46	50	36	29	38.0	43.3	9.0	2.0	4	45.0	
30	46	50	37	30	38.0	43.3	9.0	2.0	4	46.0	
32	46	50	37	30	38.0	43.3	9.0	2.0	4	46.0	
34	56	62	48	39	45.0	53.5	11.5	2.0	6	59.5	
35	56	62	48	39	45.0	53.5	11.5	2.0	6	59.5	
36	56	62	48	39	45.0	53.5	11.5	2.0	6	59.5	
38	63	70	48	39	52.0	60.5	11.5	2.0	6	59.5	
40	63	70	48	39	52.0	60.5	11.5	2.0	6	59.5	
42	63	70	48	39	52.0	60.5	11.5	2.0	6	59.5	
43	63	70	48	41	52.0	60.5	11.5	2.0	6	59.5	
45	69	75	51	41	57.0	65.5	11.5	2.0	6	62.5	
48	69	75	51	41	57.0	65.5	11.5	2.0	6	62.5	
50	76	83	55	45	64.0	72.5	11.5	2.0	6	66.5	
55	76	83	57	47	64.0	72.5	11.5	2.0	6	68.5	
60	84	90	61	49	72.0	79.3	11.5	2.0	6	72.5	
65	89	96	63	51	77.0	84.5	11.5	2.0	6	74.5	
70	94	101	63	51	82.0	89.5	11.5	2.0	6	74.5	
75	100	106	68	57	87.0	94.5	11.5	2.0	6	79.5	
80	105	111	70	59	92.0	99.5	11.5	2.0	6	81.5	
85	115	125	72	59	98.0	105.5	13.5	2.5	6	85.5	
90	120	132	75	62	105	111.5	13.5	2.5	6	88.5	
95	126	137	75	62	110	116.5	13.5	2.5	6	88.5	
100	130	143	85	75	114	119.5	13.5	2.5	6	98.5	

Dimensions subject to changes or modifications.

FN / LS15 and FN.NU / LS15DIN



COMPONENTS:

- 1 Rotating contact surface
- 2 Stationary contact surface
- 3 O-rings
- 3a O-rings
- 3b O-rings
- 4 Spring
- 5 Metal frame
- A Spacer not provided with the seal

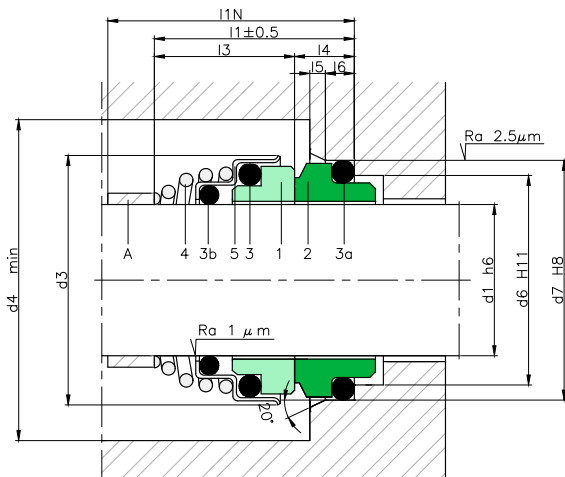

SECTORS:



CHARACTERISTICS:

- Unbalanced.
- Single conical spring.
- Dependent on the rotation direction.

OPERATING LIMITS:

$d_1 = 10 \div 40 \text{ mm}$ $p = 10 \text{ kg/cm}^2$
 $v = 20 \text{ m/s}$ $t = -20 \div +180^\circ\text{C} (*)$

(*) The temperature resistance depends on the material of the secondary seals used.

The operating limits are defined by the PV factor which is determined for the sealing system characteristics and those of the application.

DESCRIPTION:

An all-purpose mechanical seal.
 A single seal with a versatile design that can be used in applications with low demands: for pumping industrial wastewater and for household use.
 Seal compliant with standard EN 12756 (NU).

DIMENSIONS CHART FN / LS15

Dimensions in mm

Shaft mm	Rotary part			Stationary part					Total length	
	d_3	d_4	l_3	d_6	d_7	l_4	l_5	l_6	l_{1N}	l_1
10	19.5	22	15	14.0	18.1	5.5	1.2	3	20.5	
11	22.0	25	18	16.5	20.6	5.5	1.2	3	23.5	
12	22.8	25	18	16.5	20.6	5.5	1.2	3	23.5	
13	25.0	28	22	19.0	23.1	6.0	1.2	3	28.0	
14	25.0	28	22	19.0	23.1	6.0	1.2	3	28.0	
15	28.6	32	22	21.0	26.9	7.0	1.5	4	29.0	
16	28.6	32	23	21.0	26.9	7.0	1.5	4	30.0	
17	28.6	32	23	21.0	26.9	7.0	1.5	4	30.0	
18	32.7	36	24	25.0	30.9	8.0	1.5	4	32.0	
19	32.7	36	25	25.0	30.9	8.0	1.5	4	33.0	
20	32.7	36	25	25.0	30.9	8.0	1.5	4	33.0	
21	37.4	42	25	30.0	35.4	8.0	1.5	4	33.0	
22	37.4	42	25	30.0	35.4	8.0	2.0	4	33.0	
24	37.4	42	27	30.0	35.4	8.0	2.0	4	35.0	
25	40.0	45	27	33.0	38.2	8.5	2.0	4	35.5	
28	45.5	51	29	38.0	43.3	9.0	2.0	4	38.0	
30	45.5	51	30	38.0	43.3	9.0	2.0	4	39.0	
32	45.5	51	30	38.0	43.3	9.0	2.0	4	39.0	
35	50.0	55	39	45.0	53.5	11.5	2.0	6	50.5	
38	56.0	68	39	52.0	60.5	11.5	2.0	6	50.5	
40	58.0	68	39	52.0	60.5	11.5	2.0	6	50.5	

Dimensions subject to changes or modifications.

DIMENSIONS CHART FN.NU / LS15DIN

Dimensions in mm

Shaft mm	Rotary part			Stationary part					Total length	
	d_3	d_4	l_3	d_6	d_7	l_4	l_5	l_6	l_{1N}	l_1
10	20.0	22	15	17	21	7	1.5	4	40	22
12	22.0	25	18	19	23	7	1.5	4	40	25
14	24.0	28	22	21	25	7	1.5	4	40	29
16	26.0	32	23	23	27	7	1.5	4	40	30
18	32.0	36	24	27	33	10	2.0	4	45	34
20	33.0	36	25	29	35	10	2.0	5	45	35
22	36.0	42	25	31	37	10	2.0	5	45	35
24	37.4	42	27	33	39	10	2.0	5	50	37
25	38.0	45	27	34	40	10	2.0	5	50	37
28	42.0	51	29	37	43	10	2.0	5	50	39
30	44.0	51	30	39	45	10	2.0	5	50	40
32	45.5	51	30	42	48	10	2.0	5	55	40
33	46.5	51	39	42	48	10	2.0	5	55	49
35	49.0	55	39	44	50	10	2.0	5	55	49
38	56.0	68	42	49	56	13	2.0	6	55	55
40	58.0	68	42	51	58	13	2.0	6	55	55

LS18 / LS19



COMPONENTS:

- 1 Rotating contact surface
- 3 O-rings
- 4 Spring
- 5 Metal frame
- 5a Ring

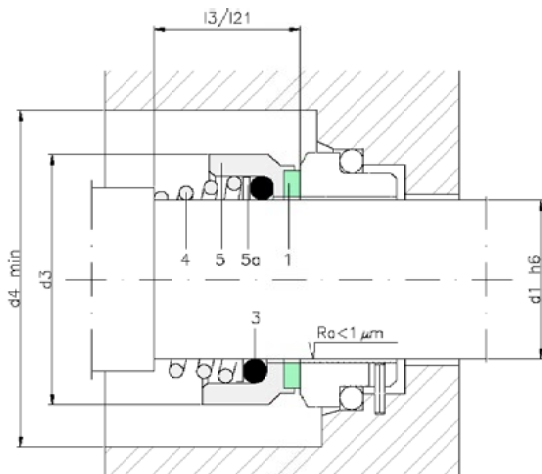

Type LS18: Working length of rotating part l_3
 Type LS19: Working length of rotating part l_{21} .

SECTORS:



CHARACTERISTICS:

- Unbalanced.
- Single conical spring.
- Dependent on the rotation direction.

OPERATING LIMITS:

$d_1 = 10 \div 80 \text{ mm}$ $p = 10 \text{ kg/cm}^2$
 $v = 20 \text{ m/s}$ $t = -20 \div +200^\circ\text{C}$ (*)

(*) The temperature resistance depends on the material of the secondary seals used.

The operating limits are defined by the PV factor which is determined for the sealing system characteristics and those of the application.

DESCRIPTION:

Single mechanical seal with an extremely versatile and functional design. The rotating part of the seal can be combined with a large variety of stationary parts, which offers a wide range of combinations. Its structure allows secondary seals made of different materials to be used: FKM, Aflas®, FFKM, FEP, NBR, HNBR and materials complying with special standards such as FDA, USP, EC, etc.

This seal may be supplied with any of the stationary parts shown in pages 56 and 58.

DIMENSIONS CHART

Dimensions in mm

Shaft mm	Rotary part			
	d_3	d_4	l_3	l_{21}
10	19	24	15,5	15,5
12	21	26	16	15,5
14	23	28	16,5	15,5
15	24	29	-	15,5
16	26	31	18	17,5
18	29	34	19,5	18,5
20	31	36	22	20
22	33	38	21,5	21,5
24	35	40	23,5	23
25	36	41	26,5	24,5
26	37	42	-	24,5
28	40	45	26,5	24,5
30	43	48	26,5	24,5
32	46	51	28,5	28
33	47	52	28,5	-
35	49	54	28,5	28
38	53	58	33,5	31
40	56	61	36	34
42	59	64	-	35
43	59	64	38,5	-
45	61	66	39,5	36,5
48	64	69	46	42
50	66	71	45	43
53	69	74	47	-
55	71	76	49	47
58	76	81	55	50
60	78	83	55	51
63	83	88	55	-
65	84	89	55	52
68	88	93	55	53
70	90	95	57	54
75	98	103	62	55
80	100	105	61,8	58

Dimensions subject to changes or modifications.

LS18B



COMPONENTS:

- 1 Rotating contact surface
- 2 Stationary contact surface
- 3 O-rings
- 3a O-rings
- 4 Spring
- 5 Metal frame

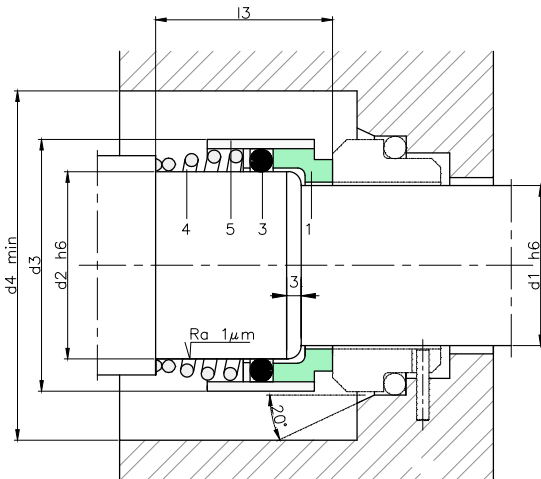

SECTORS:



CHARACTERISTICS:

- **Balanced.**
- **Single conical spring.**
- **Dependent on the rotation direction.**

OPERATING LIMITS:

$d_1 = 10 \div 80 \text{ mm}$ $p = 25 \text{ kg/cm}^2$
 $v = 15 \text{ m/s}$ $t = -20 \div +200^\circ\text{C} (*)$

(*) The temperature resistance depends on the material of the secondary seals used.

The operating limits are defined by the PV factor which is determined for the sealing system characteristics and those of the application.

DESCRIPTION:

This mechanical seal has an extremely versatile and functional design and is suitable for working at pressures of up to 25 kg/cm². The rotating part of the seal can be combined with a large variety of stationary parts, which offers a wide range of combinations. Its structure allows secondary seals made of different materials to be used: FKM, Aflas®, FFKM, FEP, NBR, HNBR and materials complying with special standards such as FDA, USP, EC 1935/2004, etc.

This seal may be supplied with any of the stationary parts shown in pages 56 and 58.

DIMENSIONS CHART

Dimensions in mm

Shaft mm	Rotary part			
	d ₂	d ₃	d ₄	l ₃
10	14	24	29	25.5
12	16	26	31	26.5
14	18	31	36	29.5
16	20	34	39	31.0
18	22	36	41	32.5
20	24	38	43	32.5
22	26	40	45	32.5
24	28	42	47	32.5
25	30	44	49	33.5
28	33	47	52	35.5
30	35	49	54	35.5
32	38	54	59	39.5
33	38	54	59	39.5
35	40	56	61	43.5
38	43	59	64	46.0
40	45	61	66	48.0
43	48	64	69	51.0
45	50	66	71	55.0
48	53	69	74	55.0
50	55	71	76	58.0
53	58	78	83	60.0
55	60	79	84	60.0
58	63	83	88	60.0
60	65	85	90	60.0
63	68	88	93	60.0
65	70	90	95	61.0
70	75	98	103	63.0
75	80	103	108	68.0
80	85	109	114	68.0

Dimensions subject to changes or modifications.

LS60IL / LS60IN



COMPONENTS:

- 1 Rotating contact surface
- 2 Stationary contact surface
- 3 O-rings
- 3a O-rings
- 4 Spring
- 5 Metal frame

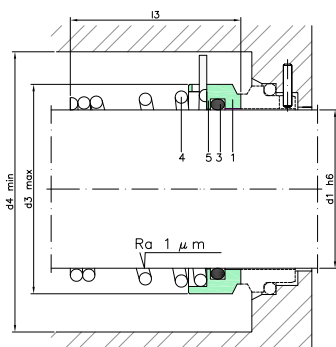

TYPE LS60 IL

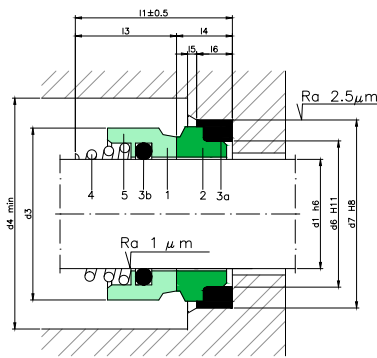

TYPE LS60 IN

SECTORS:



CHARACTERISTICS:

- Unbalanced.
- Single conical spring.
- Dependent on the rotation direction.

OPERATING LIMITS:

$d_1 = 20 \div 100 \text{ mm}$ $p = 10 \text{ kg/cm}^2$

$v = 20 \text{ m/s}$ $t = -40 \div +180^\circ\text{C}$ (*)

(*) The temperature resistance depends on the material of the secondary seals used.

The operating limits are defined by the PV factor which is determined for the sealing system characteristics and those of the application.

DESCRIPTION:

A versatile, robust single seal that is widely used in many different industrial and household applications.

DIMENSIONS CHART LS60IL

Dimensions in mm

Shaft mm	Rotary part		
	d ₃	d ₄	l ₃
18	29	32	19,5
25	36	42,6	25
30	43	52	27
35	49	58,4	30
40	56	64,6	34
48	64	72,5	34
50	68	84,5	35,5
65	86	97	40
70	89,6	92	56
80	100	116	50

DIMENSIONS CHART LS60IN

Dimensions in mm

Shaft (") mm	Rotary part			Stationary part			Total length	
	d ₃	d ₄	l ₃	d ₆	d ₇	l ₄	l ₁	
0,875	22,22	34,00	46,00	25,50	29,00	37,30	10,00	35,50
1,00	25,24	37,00	50,00	24,90	32,00	40,50	10,60	35,50
1,25	31,75	45,00	62,00	33,50	39,00	50,80	11,50	45,00

Dimensions subject to changes or modifications.

RN / LS60 and RN.NU / LS60DIN



COMPONENTS:

- 1 Rotating contact surface
- 2 Stationary contact surface
- 3 O-rings
- 3a O-rings
- 4 Spring
- 5 Metal frame
- A Spacer not provided with the seal

SECTORS:



CHARACTERISTICS:

- Unbalanced.
- Single conical spring.
- Dependent on the rotation direction.

OPERATING LIMITS:

$d_1 = 10 \div 140 \text{ mm}$ $p = 10 \text{ kg/cm}^2$
 $v = 20 \text{ m/s}$ $t = -20 \div +200^\circ\text{C} (*)$

(*) The temperature resistance depends on the material of the secondary seals used.

The operating limits are defined by the PV factor which is determined for the sealing system characteristics and those of the application.

DESCRIPTION:

A versatile, robust single seal that is widely used in many different industrial and household applications. The rotating part, with a compact design, only permits the use of secondary seals made of elastic materials. If it should be necessary to use secondary seals made of PTFE for reasons related to temperature, the RN6 model is recommended.

Types:

RN6 and RN6 DIN: Secondary seals made of PTFE and contact surfaces in GB.

RN.NU / LS60DIN: standardised models in accordance with EN 12756 NU.

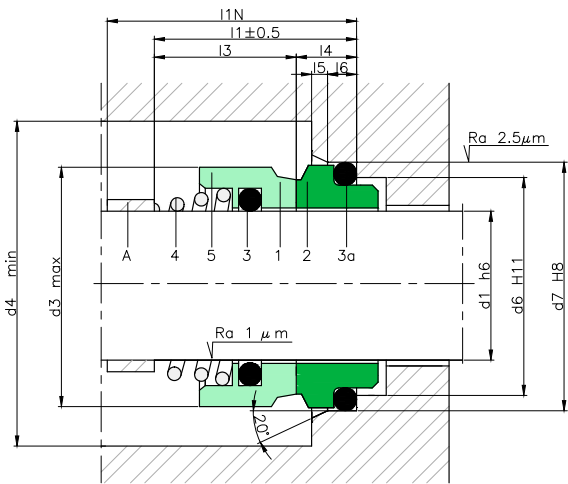

DIMENSIONS CHART RN / LS60

Dimensions in mm

Shaft mm	Rotary part			Stationary part						Total length
	d_3	d_4	l_3	d_6	d_7	l_4	l_5	l_6	l_1	
10	19.0	23.0	15	14.0	18.1	5.5	1.2	3	20.5	
11	21.0	25.0	18	16.5	20.6	5.5	1.2	3	23.5	
12	21.0	25.0	18	16.5	20.6	5.5	1.2	3	23.5	
13	23.0	27.0	22	19.0	23.1	6.0	1.2	3	28.0	
14	23.0	27.0	22	19.0	23.1	6.0	1.2	3	28.0	
15	24.0	28.0	22	21.0	26.9	7.0	1.5	4	29.0	
16	26.0	30.0	23	21.0	26.9	7.0	1.5	4	30.0	
17	26.0	30.0	23	22.0	26.9	7.0	1.5	4	30.0	
18	29.0	33.0	24	25.0	30.9	8.0	1.5	4	32.0	
19	31.0	35.0	25	25.0	30.9	8.0	1.5	4	33.0	
20	31.0	35.0	25	25.0	30.9	8.0	1.5	4	33.0	
21	33.0	37.0	25	30.0	35.4	8.0	2.0	4	33.0	
22	33.0	37.0	25	30.0	35.4	8.0	2.0	4	33.0	
23	35.0	39.0	27	30.0	35.4	8.0	2.0	4	35.0	
24	35.0	39.0	27	30.0	35.4	8.0	2.0	4	35.0	
25	36.0	40.0	27	33.0	38.2	8.5	2.0	4	35.5	
26	36.0	40.0	27	33.0	38.2	8.5	2.0	4	35.5	
27	36.0	40.0	27	33.0	38.2	8.5	2.0	4	35.5	
28	40.0	44.0	29	38.0	43.3	9.0	2.0	4	38.0	
29	43.0	47.0	30	38.0	43.3	9.0	2.0	4	39.0	
30	43.0	47.0	30	38.0	43.3	9.0	2.0	4	39.0	
31	46.0	50.0	30	38.0	43.3	9.0	2.0	4	39.0	
32	46.0	50.0	30	38.0	43.3	9.0	2.0	4	39.0	
33	46.0	50.0	39	45.0	53.5	11.5	2.0	6	50.5	
34	49.0	53.0	39	45.0	53.5	11.5	2.0	6	50.5	
35	49.0	53.0	39	45.0	53.5	11.5	2.0	6	50.5	
36	49.0	53.0	39	45.0	53.5	11.5	2.0	6	50.5	
37	49.0	53.0	39	45.0	53.5	11.5	2.0	6	50.5	
38	53.0	57.0	39	52.0	60.5	11.5	2.0	6	50.5	
39	56.0	60.0	39	52.0	60.5	11.5	2.0	6	50.5	
40	56.0	60.0	39	52.0	60.5	11.5	2.0	6	50.5	
41	56.0	60.0	39	52.0	60.5	11.5	2.0	6	50.5	
42	59.0	63.0	39	52.0	60.5	11.5	2.0	6	50.5	
43	59.0	63.0	41	57.0	60.5	11.5	2.0	6	52.5	
44	60.0	64.0	41	57.0	65.5	11.5	2.0	6	52.5	
45	61.0	65.0	41	57.0	65.5	11.5	2.0	6	52.5	
46	61.0	65.0	41	57.0	65.5	11.5	2.0	6	52.5	
47	64.0	68.0	41	57.0	65.5	11.5	2.0	6	52.5	
48	64.0	68.0	41	57.0	65.5	11.5	2.0	6	52.5	
49	64.0	68.0	41	57.0	65.5	11.5	2.0	6	52.5	
50	66.0	70.0	45	64.0	72.5	11.5	2.0	6	56.5	
55	71.0	75.0	47	64.0	72.5	11.5	2.0	6	58.5	
60	78.0	82.0	49	72.0	79.3	11.5	2.0	6	60.5	
65	84.0	88.0	51	77.0	84.5	11.5	2.0	6	62.5	
70	89.6	93.6	51	82.0	89.5	11.5	2.0	6	62.5	
75	98.0	102.0	57	87.0	94.5	11.5	2.0	6	68.5	
80	100.0	104.0	59	92.0	99.5	11.5	2.0	6	70.5	
85	107.5	111.5	59	98.0	105.5	13.5	2.5	6	72.5	
90	111.0	115.0	62	105.0	111.5	13.5	2.5	6	75.5	
95	119.0	123.0	62	110.0	116.5	13.5	2.5	6	75.5	
100	123.8	127.8	75	114.0	119.5	13.5	2.5	6	88.5	
110	136.0	140.0	75	124.0	132.2	17.5	4.0	7	92.5	
120	148.0	152.0	85	134.0	142.2	17.5	4.0	7	102.5	
130	160.0	164.0	95	145.0	153.2	17.5	4.0	7	112.5	
135	166.0	170.0	95	152.0	161.2	18.5	4.0	7	113.5	
140	171.0	175.0	100	157.0	164.3	18.5	4.0	7	118.5	

Dimensions subject to changes or modifications.

DIMENSIONS CHART RN.NU / LS60DIN

Dimensions in mm

Shaft mm	Rotary part			Stationary part						Total length
	d_3	d_4	l_3	d_6	d_7	l_4	l_5	l_6	l_{1N}	
10	19.0	22	15	17	21	7	1.5	4	40	22
12	21.0	24	18	19	23	7	1.5	4	40	25
14	23.0	26	22	21	25	7	1.5	4	40	29
16	26.0	28	23	23	27	7	1.5	4	40	30
18	29.0	34	24	27	33	10	2.0	4	45	34
20	31.0	36	25	29	35	10	2.0	5	45	35
22	33.0	38	25	31	37	10	2.0	5	45	35
24	35.0	40	27	33	39	10	2.0	5	50	37
25	36.0	41	27	34	40	10	2.0	5	50	37
28	40.0	44	29	37	43	10	2.0	5	50	39
30	43.0	46	30	39	45	10	2.0	5	50	40
32	46.0	48	30	42	48	10	2.0	5	55	40
33	46.0	49	39	42	48	10	2.0	5	55	49
35	49.0	51	39	44	50	10	2.0	5	55	49
38	53.0	58	42	49	56	13	2.0	6	55	55
40	56.0	60	42	51	58	13	2.0	6	55	55
43	59.0	63	47	54	61	13	2.0	6	60	60
45	61.0	65	47	56	63	13	2.0	6	60	60
48	64.0	68	47	59	66	13	2.0	6	60	60
50	66.0	70	46	62	70	14	2.5	6	60	60
53	69.0	73	56	65	73	14	2.5	6	70	70
55	71.0	75	56	67	75	14	2.5	6	70	70
58	76.0	83	56	70	78	14	2.5	6	70	70
60	78.0	85	56	72	80	14	2.5	6	70	70
63	81.0	88	56	75	83	14	2.5	6	70	70
65	84.0	90	66	77	85	14	2.5	6	80	80
68	88.0	93	64	81	90	16	2.5	7	80	80
70	89.6	95	64	83	92	16	2.5	7	80	80
75	98.0	104	64	88	97	16	2.5	7	80	80
80	100.0	109	72	95	105	18	3.0	7	90	90
85	107.5	114	72	100	110	18	3.0	7	90	90
90	111.0	119	72	105	115	18	3.0	7	90	90
95	119.0	124	72	110	120	18	3.0	7	90	90
100	123.8	129	72	115	125	18	3.0	7	90	90

RNB / LS60B and RN.NB / LS60BDIN



COMPONENTS:

- 1 Rotating contact surface
- 2 Stationary contact surface
- 3 O-rings
- 3a O-rings
- 4 Spring
- 5 Metal frame

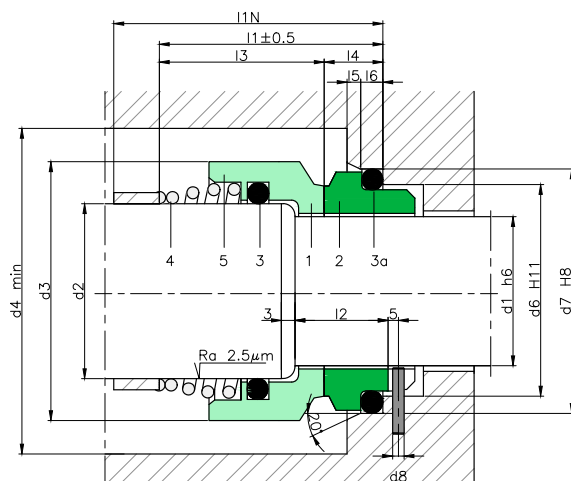

SECTORS:



CHARACTERISTICS:

- Balanced.
- Single conical spring.
- Dependent on the rotation direction.

OPERATING LIMITS:

$d_1 = 10 \div 100 \text{ mm}$ $p = 50 \text{ kg/cm}^2$
 $v = 20 \text{ m/s}$ $t = -20 \div +200^\circ\text{C (*)}$

(*) The temperature resistance depends on the material of the secondary seals used.

The operating limits are defined by the PV factor which is determined for the sealing system characteristics and those of the application.

DESCRIPTION:

A versatile, robust single seal that is widely used in many different industrial and household applications. Suitable for working at high pressures.

The rotating part, with a compact design, only permits the use of secondary seals made of elastic materials.

Types:

RN.NB/LS60BDIN: standardised models in accordance with EN 12756 NB.

DIMENSIONS CHART RNB / LS60B

Dimensions in mm

Shaft mm	Rotary part				Stationary part							Total length mm
	d ₂	d ₃	d ₄	l ₃	d ₆	d ₇	l ₂	l ₄	l ₅	l ₆	l ₇	
10	13	22	27	30	14.0	18.1	12.0	5.5	1.2	3	1.5	35.5
12	15	24	30	30	16.5	20.6	12.0	5.5	1.2	3	1.5	35.5
14	17	26	31	31	19.0	23.1	12.5	6.0	1.2	3	1.5	37.0
15	18	32	36	32	21.0	26.9	13.5	7.0	1.5	4	1.5	39.0
16	19	32	36	34	21.0	26.9	14.5	7.0	1.5	4	1.5	41.0
18	21	35	41	34	25.0	30.9	15.5	8.0	1.5	4	1.5	42.0
20	23	36	41	36	25.0	30.9	15.5	8.0	1.5	4	1.5	44.0
22	26	39	45	37	30.0	35.4	16.0	8.0	2.0	4	2.0	45.0
24	28	42	50	39	30.0	35.4	16.0	8.0	2.0	4	2.0	47.0
25	29	43	50	40	33.0	38.2	16.5	8.5	2.0	4	2.0	48.5
28	32	46	50	40	38.0	43.3	17.0	9.0	2.0	4	2.0	49.0
30	34	48	60	49	38.0	43.3	17.0	9.0	2.0	4	2.0	58.0
32	36	50	60	49	38.0	43.3	17.0	9.0	2.0	4	2.0	58.0
35	39	55	68	51	45.0	53.5	21.5	11.5	2.0	6	2.0	62.5
38	42	57	68	51	52.0	60.5	21.5	11.5	2.0	6	2.0	62.5
40	44	60	72	53	52.0	60.5	21.5	11.5	2.0	6	2.0	64.5
42	46	62	72	53	52.0	60.5	21.5	11.5	2.0	6	2.0	64.5
43	47	63	72	53	52.0	60.5	21.5	11.5	2.0	6	2.0	64.5
45	49	65	72	54	57.0	65.5	22.4	11.5	2.0	6	2.0	65.5
50	54	70	80	59	64.0	72.5	23.5	11.5	2.0	6	2.0	70.5
52	57	75	87	62	64.0	72.5	24.0	11.5	2.0	6	2.5	73.5
55	60	80	87	64	64.0	72.5	24.0	11.5	2.0	6	2.5	75.5
60	65	85	92	66	72.0	79.3	24.0	11.5	2.0	6	2.5	77.5
65	70	90	97	66	77.0	84.5	24.0	11.5	2.0	6	2.5	77.5
70	75	99	102	72	82.0	89.5	24.0	11.5	2.0	6	2.5	83.5
75	80	104	107	75	87.0	94.5	25.0	11.5	2.0	6	2.5	86.5
80	85	109	113	75	92.0	99.5	25.0	11.5	2.0	6	2.5	86.5
85	90	114	120	78	98.0	105.5	27.0	13.5	2.5	6	2.5	91.5
90	95	119	130	78	105.0	111.5	27.0	13.5	2.5	6	2.5	91.5
95	100	124	136	91	110.0	116.5	27.0	13.5	2.5	6	2.5	104.5
100	106	130	150	93	114.0	119.5	28.5	13.5	2.5	6	3.0	106.5

Dimensions subject to changes or modifications.

DIMENSIONS CHART RN.NB / LS60BDIN

Dimensions in mm

Shaft mm	Rotary part				Stationary part							Total length mm	
	d ₂	d ₃	d ₄	l ₃	d ₆	d ₇	d ₈	l ₂	l ₄	l ₅	l ₆		
10	14	24	26	43	17	21	3	18	7	1.5	4	50	50
12	16	26	28	43	19	23	3	18	7	1.5	4	50	50
14	18	32	34	39	21	25	3	18	7	1.5	4	55	46
16	20	34	36	40	23	27	3	18	7	1.5	4	55	47
18	22	36	38	41	27	33	3	20	10	2.0	5	55	51
20	24	38	40	43	29	35	3	20	10	2.0	5	60	53
22	26	40	42	43	31	37	3	20	10	2.0	5	60	53
24	28	42	44	50	33	39	3	20	10	2.0	5	60	60
25	30	44	46	50	34	40	3	20	10	2.0	5	60	60
28	33	47	49	55	37	43	3	20	10	2.0	5	65	65
30	35	49	51	55	39	45	3	20	10	2.0	5	65	65
32	38	54	58	55	42	48	3	20	10	2.0	5	65	65
33	38	54	58	55	42	48	3	20	10	2.0	5	65	65
35	40	56	60	55	44	50	3	20	10	2.0	5	65	65
38	43	59	63	62	49	56	4	23	13	2.0	6	75	75
40	45	61	65	62	51	58	4	23	13	2.0	6	75	75
43	48	64	68	62	54	61	4	23	13	2.0	6	75	75
45	50	66	70	62	56	63	4	23	13	2.0	6	75	75
48	53	69	73	72	59	66	4	23	13	2.0	6	85	85
50	55	71	75	71	62	70	4	25	14	2.5	6	85	85
53	58	78	83	71	65	73	4	25	14	2.5	6	85	85
55	60	80	85	71	67	75	4	25	14	2.5	6	85	85
58	63	83	88	71	70	78	4	25	14	2.5	6	85	85
60	65	85	90	81	72	80	4	25	14	2.5	6	95	95
63	68	88	93	81	75	83	4	25	14	2.5	6	95	95
65	70	90	95	81	77	85	4	25	14	2.5	6	95	95
70	75	99	104	79	83	92	4	28	16	2.5	7	95	95
75	80	104	109	89	88	97	4	28	16	2.5	7	105	105
80	85	109	114	87	95	105	4	28	18	3.0	7	105	105
85	90	114	119	87	100	110	4	28	18	3.0	7	105	105
90	95	119	124	87	105	115	4	28	18	3.0	7	105	105
95	100	124	129	87	110	120	4	28	18	3.0	7	105	105
100	105	129	134	87	115	125	4	28	18	3.0	7	105	105

LS40A



COMPONENTS:

- 1 Rotating contact surface
- 2 Stationary contact surface
- 3 O-rings
- 3a O-rings
- 4 Spring
- 5 Metal frame
- 5a Set screws

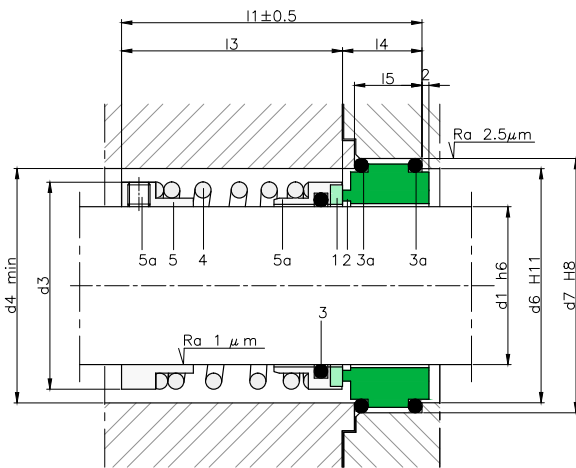

SECTORS:



CHARACTERISTICS:

- Unbalanced.
- Single cylindrical spring.
- Dependent on the rotation direction.
- System attached to the shaft by allen screws.

OPERATING LIMITS:

$d_1 = 20 \div 100 \text{ mm}$ $p = 12 \text{ kg/cm}^2$

$v = 15 \text{ m/s}$ $t = -20 \div +200^\circ\text{C} (*)$

(*) The temperature resistance depends on the material of the secondary seals used.

The operating limits are defined by the PV factor which is determined for the sealing system characteristics and those of the application.

DESCRIPTION:

Single mechanical seal with an extremely versatile and functional design.

The fact that it is attached to the shaft with screws allows this seal to be installed in a large variety of applications with differing mounting dimensions.

Its structure allows secondary seals made of different materials to be used: FKM, Atlas®, FFKM, FEP, NBR, HNBR and materials complying with special standards such as FDA, USP, EC, etc.

DIMENSIONS CHART

Dimensions in mm

Shaft mm	Rotary part			Stationary part				Total length l ₁
	d ₃	d ₄	l ₃	d ₆	d ₇	l ₄	l ₅	
20	34	36	46	36	42	23	18	69
22	36	38	46	38	44	23	18	69
24	38	40	46	40	46	23	18	69
25	39	41	47	41	47	23	18	70
28	42	44	49	44	50	23	20	72
30	44	46	49	46	52	23	20	72
32	46	48	52	48	54	23	18	75
33	47	49	52	49	55	23	18	75
35	49	51	55	51	57	23	18	78
38	54	58	57	58	64	25	20	82
40	56	60	57	60	66	25	20	82
43	59	63	57	63	69	25	20	82
45	61	65	57	65	71	25	20	82
48	64	68	64	68	74	25	20	89
50	66	70	68	70	76	25	20	93
53	69	73	69	73	79	25	20	94
55	71	75	71	75	81	25	20	96
58	76	83	71	83	89	28	20	99
60	78	85	74	85	91	28	22	102
63	81	88	74	88	94	28	22	102
65	83	90	78	90	96	28	22	106
68	86	93	78	93	99	30	22	106
70	90	95	79	95	101	30	24	109
75	95	104	84	104	110	30	24	114
80	100	109	84	109	115	31	24	115
85	105	114	84	114	120	31	25	115
90	110	119	90	119	125	31	24	121
95	115	124	90	124	130	31	25	121
100	121	129	90	129	135	31	25	121

Dimensions subject to changes or modifications.

LS40C



COMPONENTS:

- 1 Rotating contact surface
- 2 Stationary contact surface
- 3 O-rings
- 3a O-rings
- 4 Spring
- 5 Metal frame
- 5a Set screws

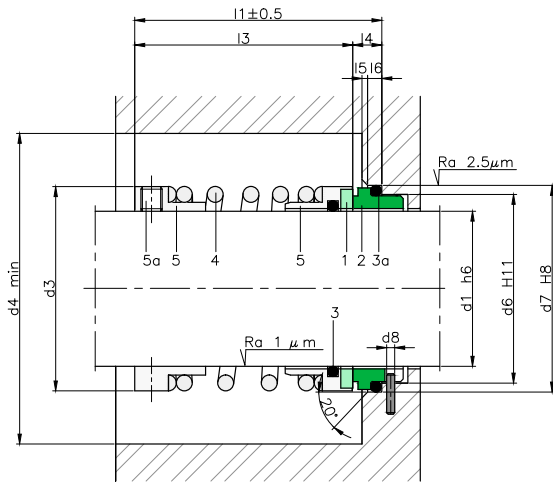

SECTORS:



CHARACTERISTICS:

- Unbalanced.
- Single cylindrical spring.
- Dependent on the rotation direction.
- System attached to the shaft by allen screws.

OPERATING LIMITS:

$d_1 = 20 \div 100 \text{ mm}$ $p = 12 \text{ kg/cm}^2$
 $v = 15 \text{ m/s}$ $t = -20 \div +200^\circ\text{C}$ (*)

(*) The temperature resistance depends on the material of the secondary seals used.

The operating limits are defined by the PV factor which is determined for the sealing system characteristics and those of the application.

DESCRIPTION:

Single mechanical seal with an extremely versatile and functional design. The fact that it is attached to the shaft with screws allows this seal to be installed in a large variety of applications with differing mounting dimensions. Its structure allows secondary seals made of different materials to be used: FKM, Aflas®, FFKM, FEP, NBR, HNBR and materials complying with special standards such as FDA, USP, EC, etc.

DIMENSIONS CHART

Dimensions in mm

Shaft mm	Rotary part			Stationary part				Total length l_1
	d_3	d_4	l_3	d_6	d_7	d_8	l_4	
20	34.50	39.05	35.50	29.06	33.32	3.50	9.0	44.50
22	34.93	39.93	35.50	30.66	34.93	3.50	9.0	44.50
25	38.10	43.10	39.00	33.84	39.85	3.50	10.0	49.00
28	42.86	47.86	41.00	37.01	43.05	3.50	10.0	51.00
30	45.50	50.50	41.00	38.61	44.63	3.50	10.0	51.00
32	47.00	52.00	44.00	40.28	46.32	3.50	10.0	54.00
35	50.00	55.00	47.00	43.46	49.48	3.50	10.0	57.00
38	53.00	58.00	47.00	46.63	52.56	3.50	10.0	57.00
40	55.00	60.00	47.00	48.13	54.25	3.50	10.0	57.00
45	60.00	65.00	47.00	52.98	59.02	3.50	10.0	57.00
48	61.91	66.91	55.00	57.66	63.68	4.50	10.0	65.00
50	66.00	71.00	58.50	59.33	65.37	4.50	10.0	68.50
55	71.00	76.00	60.00	64.01	70.03	4.50	10.0	70.00
60	77.00	82.00	63.00	70.36	76.38	4.50	10.0	73.00
65	82.00	87.00	66.00	75.21	81.23	4.50	10.0	76.00
70	87.00	92.00	66.00	79.88	85.90	4.50	10.0	76.00
75	91.50	96.50	71.00	84.73	90.77	4.50	10.0	81.00
80	99.50	104.50	77.50	94.26	100.29	4.50	10.0	87.50
85	105.50	110.50	77.50	98.93	104.77	4.50	10.0	87.50
90	110.50	115.50	82.00	113.78	109.82	4.50	10.0	92.00
95	115.50	120.50	82.00	108.46	114.33	4.50	10.0	92.00
100	120.00	125.50	82.00	113.31	119.33	4.50	10.0	92.00

Dimensions subject to changes or modifications.

LMB84



COMPONENTS:

- 1 Rotating contact surface
- 3 O-rings
- 4 Metal bellows.
- 5 Set screws
- 6 Metal frame

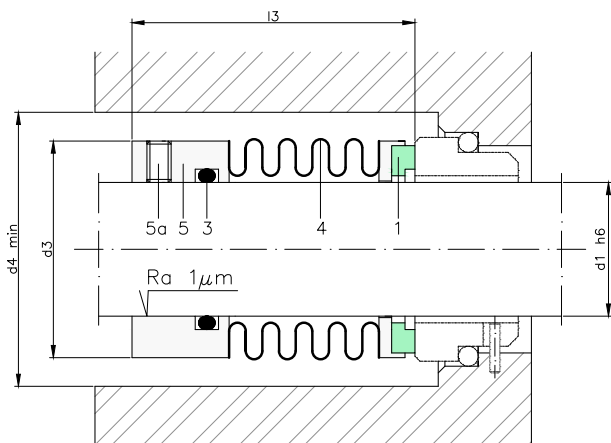

SECTORS:



CHARACTERISTICS:

- **Balanced.**
- Spiral-wound metal bellows.
- **Not dependent on the rotation direction.**

OPERATING LIMITS:

$d_1 = 18 \div 100 \text{ mm}$ $p = 20 \text{ kg/cm}^2$
 $v = 25 \text{ m/s}$ $t = -40 \div +200^\circ\text{C} (*)$

(*) The temperature resistance depends on the material of the secondary seals used.

The operating limits are defined by the PV factor which is determined for the sealing system characteristics and those of the application.

DESCRIPTION:

Balanced by the bellows, without the need for a stepped shaft (models LWS10B, LMS20B). Suitable for working in applications with high pressures. The O-ring resting on the shaft does not cause wear as there is no axial movement (changes in pressure). Recommended for working with sticky or viscous fluids that require cleaning processes (CIP) or sterilisation processes (SIP) in situ due to the geometry of the spiral-wound bellows.

This seal may be supplied with any of the stationary parts shown in pages 56 and 57. for measurements in mm, and 58 for the measurements in inches.

DIMENSIONS CHART

Dimensions in mm

Shaft mm	Rotary part		
	d ₃	d ₄	l ₃
18	31	34	31,5
20	31	36	31,5
22	31	38	31,5
24	36	40	36,7
25	36	41	37
28	39	44	37,5
30	42	46	38
32	46	48	43
33	46	49	43
35	48,5	51	43
38	51,5	58	42
40	54	60	42
43	58,4	63	47
45	58,4	65	47
48	63,7	68	47
50	63,7	70	46,5
53	69	73	56,5
55	71	75	56,5
58	73,3	83	56,5
60	76,7	85	56,5
63	79,4	88	56,5
65	83	90	66,5
68	87,8	93	66,5
70	87,8	95	65,5
75	94	104	65,5
80	100,6	109	75
85	106	114	75
90	110,3	119	75
95	114,9	124	75
100	121,3	129	75

Dimensions in mm

Shaft (")	Rotary part			
	mm	d ₃	d ₄	l ₃
0,750	19,05	31	34,9	31,5
0,875	22,23	36	38,1	37
1,000	25,40	39	41,3	37,5
1,125	28,58	42	44,5	38
1,250	31,75	46	47,6	43
1,375	34,93	48,5	50,8	43
1,500	38,10	51,5	57,2	42
1,625	41,28	58,4	60,3	47
1,750	44,45	58,4	63,5	47
1,875	47,63	63,7	66,7	46,5
2,000	50,80	63,7	69,9	46,5
2,125	53,98	69	73	56,5
2,250	57,15	73,3	76,2	56,5
2,375	60,33	76,7	79,4	56,5
2,500	63,50	79,4	82,6	56,5
2,625	66,68	83	85,7	66,5
2,750	69,85	87,8	96	65,5
2,875	73,03	94	99	65,5
3,000	76,20	94	100	65,5
3,125	79,38	100,6	104	75
3,250	82,55	100,6	108	75
3,375	85,73	106	111	75
3,500	88,90	110,3	115	75
3,625	92,08	114,9	118	75
3,750	95,25	114,9	121	75
3,875	98,43	121,3	124	75
4,000	101,60	121,3	127	75

Dimensions subject to changes or modifications.

LMB85



COMPONENTS:

- 1 Rotating contact surface
- 2 Stationary contact surface
- 3 O-rings
- 3a O-rings
- 4 Metal bellows
- 5 Metal frame
- 5a Set screws

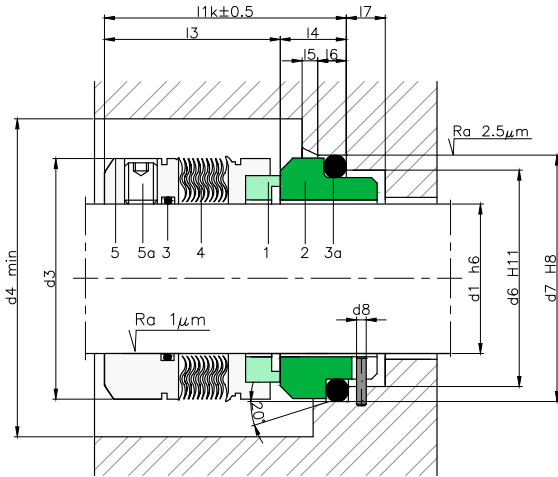

SECTORS:



CHARACTERISTICS:

- **Balanced.**
- **Welded metal bellows.**
- **Not dependent on the rotation direction.**

OPERATING LIMITS:

$d_1 = 16 \div 100 \text{ mm}$ $p = 20 \text{ kg/cm}^2$
 $v = 25 \text{ m/s}$ $t = -40 \div +200^\circ\text{C}$
 -40 ÷ +200 °C (up to 400° C with a special design) (*)

(*) The temperature resistance depends on the material of the secondary seals used.

The operating limits are defined by the PV factor which is determined for the sealing system characteristics and those of the application.

DESCRIPTION:

Internally balanced, with no need for a stepped shaft (models LWS10B, LMS20B). The O-ring resting on the shaft does not cause wear as there is no axial movement. Appropriate for applications with sticky or high viscosity fluids as its open leaf design generates a self-cleaning effect. In addition it is suitable for application at moderate pressures and high temperatures (for up to 400° C please enquire) and very aggressive fluids in chemical and mechanical terms. Very often used in compressors.

DIMENSIONS CHART

Dimensions in mm

Shaft mm	Rotary part		
	d ₃	d ₄	l ₃
20	33,5	37,5	30,5
22	36,5	40,5	30,5
24	39,6	43	28,5
25	39,6	43	28,5
28	42,8	46,8	31
30	45	49	31
32	46	50	31
33	48	52	31
35	49,2	63,2	31
38	52,3	56,3	31
40	55,5	59,5	31
43	57,5	61,5	31
45	58,7	62,7	31
48	63	67	31
50	65	69	32,5
53	68,2	72,2	32,5
55	70	74	32,5
58	71,7	75,7	37,5
60	74,6	78,6	37,5
63	79	83	37,5
65	84,1	88,1	37,5
68	87,3	91,3	34,5
70	87,3	91,3	42
75	95	99	42
80	98,4	102,4	41,8
85	104,7	108,7	41,8
90	111	115	46,8
95	114	118	47,8
100	120	125	47,8

Dimensions in inches

Shaft (")	mm	Rotary part			Stationary part			Total length l ₁
		d ₃	d ₄	l ₃	d ₆	d ₇	l ₄	
0,750	19,05	34	38	30,5	29,5	35	11,5	42
0,875	22,23	39	43	28,5	33,5	39	11,5	40
1,000	25,40	39,6	43,6	28,5	34,5	40	11,5	40
1,125	28,58	42,8	46,8	31	37,5	43	11,5	42,5
1,250	31,75	46	50	31	42,5	48	11,5	42,5
1,375	34,93	49,2	53,2	31	44,5	50	11,5	42,5
1,500	38,10	52,5	56,5	31	49,5	56	14	45
1,625	41,28	55,5	59,5	31	54,5	61	14	45
1,750	44,45	59,5	63,5	31	56,5	63	14	45
1,875	47,63	62,5	66,5	31	59,5	66	14	45
2,000	50,80	65	69	32,5	62,5	70	15	47,5
2,125	53,98	68,2	72,2	32,5	67,5	75	15	47,5
2,250	57,15	71,7	75,7	37,5	70,5	78	15	52,5
2,375	60,33	75	79	37,5	72,5	80	15	52,5
2,500	63,50	79	83	37,5	75,5	83	15	52,5
2,625	66,68	84,1	88,1	34,5	81,5	90	18	52,5
2,750	69,85	87,3	91,3	42	83,5	92	18	60
2,875	73,03	92	96	42	88,5	97	18	60
3,000	76,20	95	99	42	88,5	97	18	60
3,125	79,38	98,4	102,4	41,8	95,5	105	18,2	60
3,250	82,55	101,6	105,6	41,8	100,5	110	18,2	60
3,375	85,73	104,7	108,7	41,8	100,5	110	18,2	60
3,500	88,90	108	112	46,8	105,5	115	18,2	65
3,625	92,08	111	115	46,8	105,5	115	18,2	65
3,750	95,25	114	118	47,8	110,5	120	17,2	65
3,875	98,43	117,5	121,5	47,8	115,5	125	17,2	65
4,000	101,60	120	125	47,8	115,5	125	17,2	65

Dimensions subject to changes or modifications.

LMB86



COMPONENTS:

- 1 Rotating contact surface
- 3 Graphite wedge
- 4 Metal bellows
- 5 Metal frame
- 5a Set screws
- 5b Tightening screw

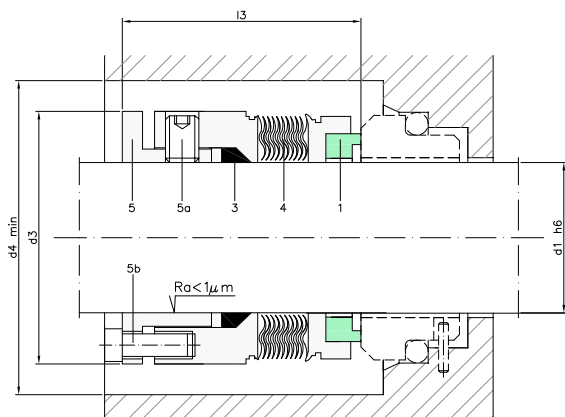

SECTORS :



CHARACTERISTICS:

- **Balanced.**
- Graphite wedge
- **Welded metal bellows.**
- Not dependent on the rotation direction.

OPERATING LIMITS:

$d_1 = 25 \div 100 \text{ mm}$ $p = 20 \text{ kg/cm}^2$
 $v = 25 \text{ m/s}$ $t = -75 \div -425^\circ\text{C} (*)$

(*) The temperature resistance depends on the material of the secondary seals used.

The operating limits are defined by the PV factor which is determined for the sealing system characteristics and those of the application.

DESCRIPTION :

Internally balanced, with no need for a stepped shaft (models LWS10B, LMS20B). The graphite wedge allows applications at very high temperatures.

Appropriate for applications with sticky or high viscosity fluids as its open leaf design generates a self-cleaning effect.

In addition it is suitable for application at moderate pressures as well as with very aggressive fluids, both chemically and mechanically terms. Very often used in compressors.

This seal may be supplied with any of the stationary parts shown in pages 56 and 57. for measurements in mm, and 58 for the measurements in inches.

DIMENSIONS CHART

Dimensions in mm

Shaft mm	Rotary part		
	d ₃	d ₄	l ₃
25	41,28	46,28	38,89
28	44,45	49,45	39,67
32	47,63	52,63	40,46
35	50,80	55,80	40,46
38	53,98	58,98	40,46
40	57,15	62,15	40,46
45	60,33	65,33	41,28
48	63,50	68,50	41,28
50	66,68	71,68	42,06
55	69,85	74,85	42,06
60	76,20	81,20	43,66
65	82,55	87,55	44,45
70	88,90	93,90	45,24
75	96,82	101,82	47,63
80	101,60	106,60	47,63
85	107,95	112,95	47,63
90	111,13	116,13	47,63
95	117,48	122,48	47,63
100	123,83	128,83	47,63

Dimensions subject to changes or modifications.

Dimensions in inches

Shaft (")	Rotary part			
	mm	d ₃	d ₄	l ₃
1,000	25,40	41,28	46,28	38,89
1,125	28,58	44,45	49,45	39,67
1,250	31,75	47,63	52,63	40,46
1,375	34,93	50,80	55,80	40,46
1,500	38,10	53,98	58,98	40,46
1,625	41,28	57,15	62,15	40,46
1,750	44,45	60,33	65,33	41,28
1,875	47,63	63,50	68,50	41,28
2,000	50,80	66,68	71,68	42,06
2,125	53,98	69,85	74,85	42,06
2,250	57,15	73,03	78,03	43,66
2,375	60,33	76,20	81,20	43,66
2,500	63,50	82,55	87,55	44,45
2,625	66,68	85,73	90,73	45,24
2,750	69,85	88,90	93,90	45,24
2,875	73,03	93,65	98,65	47,63
3,000	76,20	96,82	101,82	47,63
3,125	79,38	101,60	106,60	47,63
3,250	82,55	104,78	109,78	47,63
3,375	85,73	107,95	112,95	47,63
3,500	88,90	111,13	116,13	47,63
3,625	92,08	114,30	119,30	47,63
3,750	95,25	117,48	122,48	47,63
3,875	98,43	120,65	125,65	47,63
4,000	101,60	123,83	128,83	47,63

LRB00



COMPONENTS:

- 1 Rotating contact surface
- 2 Stationary contact surface
- 3 Bellows
- 3a Elastomeric cup
- 4 Spring
- 5 Ring
- 5a Drive ring
- 5b Metal frame

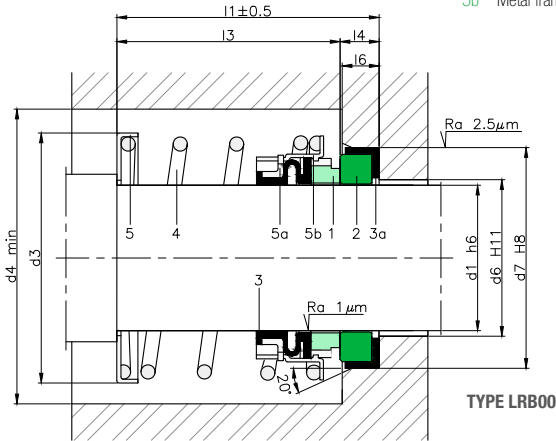

SECTORS:



CHARACTERISTICS:

- **Balanced.**
- **Not dependent on the rotation direction.**
- **Single cylindrical spring.**

OPERATING LIMITS:

$d_1 = 9.52 \div 101.60 \text{ mm}$ $p = 14 \text{ kg/cm}^2$
 $v = 13 \text{ m/s}$ $t = -20 \div +200^\circ\text{C} (*)$

(*) The temperature resistance depends on the material of the secondary seals used.

The operating limits are defined by the PV factor which is determined for the sealing system characteristics and those of the application.

DESCRIPTION:

Mechanical seal with a simple, compact design for all-purpose use and in particular in applications with moderate pressures (up to 14 kg/cm²) such as pumps and compressors.

DIMENSIONS CHART LRB00

Dimensions in inches

Shaft (")	Rotary part			Stationary part				Total length l ₁	
	d ₃	d ₄	l ₃	d ₆	d ₇	l ₄	l ₅		
3/8	9.52	28	32	25	11.0	24.6	8.7	7.1	33.7
1/2	12.70	32	36	25	13.5	27.8	8.7	7.1	33.7
5/8	15.88	35	39	25	17.0	30.9	10.5	8.7	35.5
3/4	19.05	40	44	25	20.0	34.1	10.5	8.7	35.5
13/16	20.63	41	45	25	22.0	35.7	10.5	8.7	35.5
7/8	22.22	43	47	25	23.0	37.3	10.5	8.7	35.5
1	25.40	47	51	25	26.5	40.5	10.5	8.7	35.5
1 1/8	28.57	56	60	33	29.5	47.6	12.0	10.3	45.0
1 1/4	31.75	59	63	33	32.5	50.8	12.0	10.3	45.0
1 3/8	34.92	63	67	33	36.5	54.0	12.0	10.3	45.0
1 1/2	38.10	67	71	33	39.5	57.1	12.0	10.3	45.0
1 5/8	41.27	71	75	33	42.5	60.3	12.0	10.3	45.0
1 3/4	44.45	74	78	41	46.0	63.5	12.0	10.3	53.0
1 7/8	47.62	77	81	41	49.0	66.7	12.0	10.3	53.0
2	50.80	81	85	41	52.0	69.8	13.5	12.0	54.5
2 1/8	53.97	84	88	41	55.5	73.1	13.5	12.0	54.5
2 1/4	57.15	88	92	41	58.5	76.2	13.5	12.0	54.5
2 3/8	60.32	91	95	41	61.5	79.4	13.5	12.0	54.5
2 1/2	63.50	94	98	41	65.0	82.5	13.5	12.0	54.5
2 5/8	66.67	100	104	49	68.0	92.1	16.0	14.3	65.0
2 3/4	69.85	103	107	49	71.0	95.2	16.0	14.3	65.0
2 7/8	73.02	108	112	52	74.5	98.4	16.0	14.3	68.0
3	76.20	111	115	52	77.5	101.6	16.0	14.3	68.0
3 1/8	79.37	118	122	56	80.5	111.1	20.0	18.3	76.0
3 1/4	82.55	121	125	56	84.0	114.3	20.0	18.3	76.0
3 3/8	85.72	125	129	56	87.0	117.5	20.0	18.3	76.0
3 1/2	88.90	128	132	56	90.5	120.6	20.0	18.3	76.0
3 5/8	92.07	131	135	59	93.5	123.8	20.0	18.3	79.0
3 3/4	95.25	134	138	59	96.5	127.0	20.0	18.3	79.0
3 7/8	98.42	139	143	62	100.0	130.2	20.0	18.3	82.0
4	101.60	142	146	62	103.0	133.3	20.0	18.3	82.0

Dimensions subject to changes or modifications.

LRBOOU and LRBOOL



COMPONENTS:

- 1 Rotating contact surface
- 2 Stationary contact surface
- 3 Bellows
- 3a Elastomeric cup
- 4 Spring
- 5 Ring
- 5a Drive ring
- 5b Metal frame

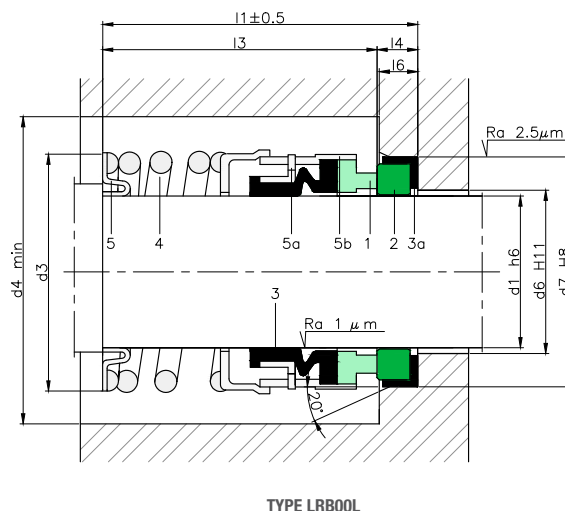
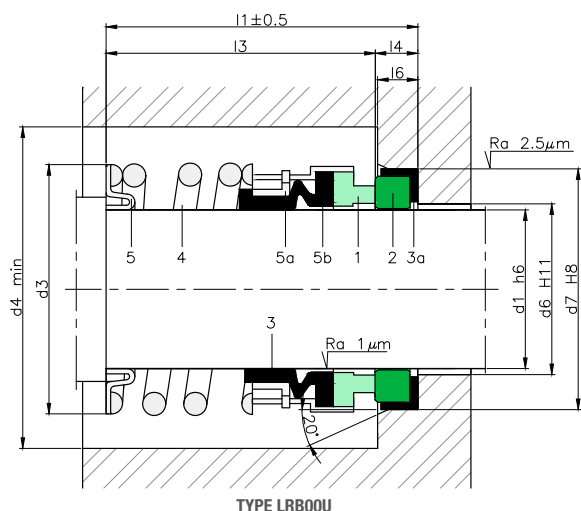

DIMENSIONS CHART LRBOOU

Dimensions in inches

Shaft		Rotary part			Stationary part				Total length
(")	mm	d ₃	d ₄	l ₃	d ₆	d ₇	l ₄	l ₆	l ₁
5/8	15.88	27.8	31.8	33.3	23.80	31.75	10.3	8.7	43.6
3/4	19.05	30.9	34.9	33.3	26.98	34.93	10.3	8.7	43.6
7/8	22.23	34.1	38.1	33.3	30.15	38.10	10.3	8.7	43.6
1	25.40	38.1	42.1	39.7	33.32	41.28	11.1	9.5	50.8
1 1/8	28.58	41.3	45.3	41.3	36.50	44.44	11.1	9.5	52.4
1 1/4	31.75	46.0	50.0	41.3	39.70	47.63	11.1	9.5	52.4
1 3/8	34.93	47.6	51.6	42.9	42.84	50.80	11.1	9.5	54.0
1 1/2	38.10	50.8	54.8	42.9	46.05	53.98	11.1	9.5	54.0
1 5/8	41.28	57.2	61.2	50.8	50.80	60.33	12.7	11.1	63.5
1 3/4	44.45	60.4	64.4	50.8	53.97	63.50	12.7	11.1	63.5
1 7/8	47.63	63.5	67.5	54.0	57.15	66.68	12.7	11.1	66.7
2	50.80	66.7	70.7	54.0	60.32	69.85	12.7	11.1	66.7
2 1/8	53.98	71.4	75.4	60.3	60.32	76.20	14.2	12.7	74.5
2 1/4	57.15	74.6	78.6	60.3	61.90	79.38	14.2	12.7	74.5
2 3/8	60.33	78.3	82.3	63.5	67.39	82.55	14.2	12.7	77.7
2 1/2	63.50	81.0	85.0	63.5	68.25	85.73	14.2	12.7	77.7
2 5/8	66.68	85.7	89.7	69.9	71.42	85.73	15.8	14.5	85.7
2 3/4	69.85	88.9	92.9	69.9	74.60	88.90	15.8	14.5	85.7
2 7/8	73.03	92.1	96.1	73.0	77.77	95.25	15.8	14.5	88.8
3	76.20	95.3	99.3	73.0	80.95	98.43	15.8	14.5	88.8
3 1/8	79.38	101.6	105.6	79.4	84.12	101.60	19.8	16.6	99.2
3 1/4	82.55	104.8	108.8	79.4	87.30	104.78	19.8	16.6	99.2
3 3/8	85.73	108.0	112.0	79.4	90.47	107.95	19.8	16.6	99.2
3 1/2	88.90	111.1	115.1	79.4	93.65	111.13	19.8	16.6	99.2
3 5/8	92.08	114.3	118.3	82.6	96.82	114.30	19.8	16.6	102.4
3 3/4	95.25	117.7	121.7	82.6	100.00	117.48	19.8	16.6	102.4
3 7/8	98.43	120.7	124.7	85.7	103.17	120.65	19.8	16.6	105.5
4	101.60	123.8	127.8	85.7	106.35	123.85	19.8	16.6	105.5

Dimensions subject to changes or modifications.

DIMENSIONS CHART LRBOOL

Dimensions in inches

Shaft		Rotary part			Stationary part				Total length
(")	mm	d ₃	d ₄	l ₃	d ₆	d ₇	l ₄	l ₆	l ₁
5/8	15.88	27.8	31.8	44	17.0	30.9	10.5	8.7	54.5
3/4	19.05	30.9	34.9	44	20.0	34.1	10.5	8.7	54.5
7/8	22.23	34.1	38.1	44	23.0	37.3	10.5	8.7	54.5
1	25.40	38.1	42.1	44	26.5	40.5	10.5	8.7	54.5
1 1/8	28.58	41.3	45.3	60	29.5	47.6	12.0	10.3	72.0
1 1/4	31.75	46.0	50.0	60	32.5	50.8	12.0	10.3	72.0
1 3/8	34.93	47.6	51.6	60	36.5	54.0	12.0	10.3	72.0
1 1/2	38.10	50.8	54.8	60	39.5	57.1	12.0	10.3	72.0
1 5/8	41.28	57.2	61.2	60	42.5	60.3	12.0	10.3	72.0
1 3/4	44.45	60.4	64.4	71	46.0	63.5	12.0	10.3	83.0
1 7/8	47.63	63.5	67.5	71	49.0	66.7	12.0	10.3	83.0
2	50.80	66.7	70.7	71	52.0	69.8	13.5	12.0	84.5
2 1/8	53.98	71.4	75.4	71	55.5	73.1	13.5	12.0	84.5
2 1/4	57.15	74.6	78.6	71	58.5	76.2	13.5	12.0	84.5
2 3/8	60.33	78.3	82.3	71	61.5	79.4	13.5	12.0	84.5
2 1/2	63.50	81.0	85.0	71	65.0	82.5	13.5	12.0	84.5
2 5/8	66.68	85.7	89.7	70	68.0	92.1	16.0	14.3	86.0
2 3/4	69.85	88.9	92.9	70	71.0	95.2	16.0	14.3	86.0
2 7/8	73.03	92.1	96.1	73	74.5	98.4	16.0	14.3	89.0
3	76.20	95.3	99.3	73	77.5	101.6	16.0	14.3	89.0
3 1/8	79.38	101.6	105.6	79	80.5	111.1	20.0	18.3	99.0
3 1/4	82.55	104.8	108.8	79	84.0	114.3	20.0	18.3	99.0
3 3/8	85.73	108.0	112.0	79	87.0	117.5	20.0	18.3	99.0
3 1/2	88.90	111.1	115.1	79	90.5	120.6	20.0	18.3	99.0
3 5/8	92.08	114.3	118.3	83	93.5	123.8	20.0	18.3	103.0
3 3/4	95.25	117.7	121.7	83	96.5	127.0	20.0	18.3	103.0
3 7/8	98.43	120.7	124.7	86	100.0	130.2	20.0	18.3	106.0
4	101.60	123.8	127.8	86	103.0	133.3	20.0	18.3	106.0

Dimensions subject to changes or modifications.

LRB01-LRB01S -LRB04 - LRB04A and LRB06



COMPONENTS:

- 1 Rotating contact surface
- 2 Stationary contact surface
- 3 Bellows
- 3a Elastomeric cup
- 4 Spring
- 5 Ring
- 5a Drive ring
- 5b Metal frame

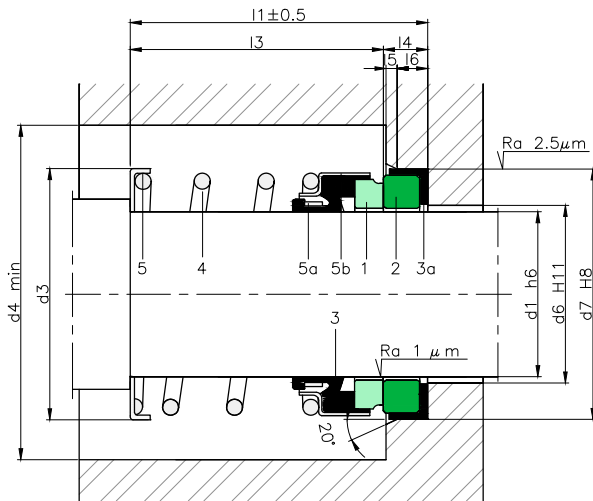

SECTORS:



CHARACTERISTICS:

- Unbalanced.
- Not dependent on the rotation direction.
- Single cylindrical spring.

OPERATING LIMITS:

$d_i = 9.52 \div 101.60 \text{ mm}$ $p = 10 \text{ kg/cm}^2$

$v = 10 \text{ m/s}$

$t = -15 \div +200^\circ \text{C} (*)$

(*) The temperature resistance depends on the material of the secondary seals used.

The operating limits are defined by the PV factor which is determined for the sealing system characteristics and those of the application.

DESCRIPTION:

Mechanical seal with a simple design for general use. Type LRB04/ LRB04A are standardised models in accordance with EN 12756 (KU).

DIMENSIONS CHART LRB01

Dimensions in inches

Shaft		Rotary part			Stationary part					Total length
(")	mm	d ₃	d ₄	l ₃	d ₆	d ₇	l ₄	l ₅	l ₆	l ₁
3/8	9.52	23.80	28.80	22.20	15.90	22.22	6.3	1.3	5.1	28.50
1/2	12.70	23.80	28.80	20.60	19.05	25.40	8.0	1.3	5.1	28.60
5/8	15.88	26.50	31.50	22.20	22.20	31.75	10.3	1.3	7.5	32.50
3/4	19.05	30.50	35.50	22.20	25.40	34.93	10.3	1.3	7.5	32.50
7/8	22.20	34.00	39.50	24.00	28.60	38.10	10.3	1.3	7.5	34.30
1	25.40	40.00	45.00	25.40	31.80	41.28	11.0	1.3	8.3	36.40
1 1/8	28.60	44.50	49.50	27.00	35.70	44.45	11.0	1.3	8.3	38.00
1 1/4	31.75	46.50	52.00	27.00	38.90	47.66	11.0	1.3	8.3	38.00
1 3/8	34.92	51.50	56.50	28.50	42.10	50.80	11.0	1.3	8.3	39.50
1 1/2	38.10	54.00	60.00	28.50	45.20	54.00	11.0	1.3	8.3	39.50
1 5/8	41.27	58.00	63.00	35.00	48.80	60.30	12.7	1.3	9.8	47.70
1 3/4	44.45	61.50	66.50	35.00	51.60	63.50	12.7	1.3	9.8	47.70
1 7/8	47.62	65.50	70.50	38.00	54.80	66.65	12.7	1.3	9.8	50.70
2	50.80	70.50	75.50	38.00	58.00	69.85	12.7	1.3	9.8	50.70
2 1/8	53.97	75.00	80.00	43.00	62.00	76.20	14.3	1.3	11.4	57.30
2 1/4	57.15	79.00	84.00	43.00	65.00	79.40	14.3	1.3	11.4	57.30
2 3/8	60.32	82.00	87.00	46.00	68.00	82.55	14.3	1.3	11.4	60.30
2 1/2	63.50	87.00	92.00	46.00	71.20	85.70	14.3	1.3	11.4	60.30
2 5/8	66.68	88.00	96.50	49.20	71.00	85.70	15.9	1.3	13.2	65.10
2 3/4	69.85	90.00	98.00	49.20	74.60	88.90	15.9	1.3	13.2	65.10
2 7/8	73.03	95.00	104.00	52.40	77.80	95.25	15.9	1.3	13.2	68.30
3	76.20	99.00	104.00	52.40	81.00	98.43	15.9	1.3	13.2	68.30
3 1/8	79.38	104.00	109.00	55.50	80.10	101.60	19.8	1.3	15.4	74.90
3 1/4	82.55	109.00	114.00	55.50	87.30	104.78	19.8	1.3	15.4	74.90
3 3/8	85.73	109.00	114.00	55.50	90.50	107.95	19.8	1.3	15.4	74.90
3 1/2	88.90	114.00	119.00	55.50	93.60	111.13	19.8	1.3	15.4	74.90
3 5/8	92.08	119.00	124.00	58.70	96.80	114.30	19.8	1.3	15.4	78.50
3 3/4	95.25	119.00	124.00	58.70	100.00	117.48	19.8	1.3	15.4	78.50
3 7/4	98.43	124.00	129.00	61.90	103.10	120.65	19.8	1.3	15.4	81.70
4	101.60	124.00	129.00	61.90	106.30	123.83	19.8	1.3	15.4	81.70

Dimensions subject to changes or modifications.

DIMENSIONS CHART LRB01S

Dimensions in inches

Shaft		Rotary part			Stationary part					Total length
(")	mm	d ₃	d ₄	l ₃	d ₆	d ₇	l ₄	l ₅	l ₆	l ₁
3/8	9.52	22	27	25.4	16	24.6	8.7	1.3	6.2	34.1
1/2	12.70	26	31	25.4	19	27.8	8.7	1.3	6.2	34.1
5/8	15.88	32	37	25.4	22	30.9	10.3	1.3	9.0	35.7
3/4	19.05	36	41	25.4	25	34.1	10.3	1.3	9.0	35.7
7/8	22.20	39	44	25.4	28	37.3	10.3	1.3	9.0	35.7
1	25.40	42	47	25.4	32	40.5	10.3	1.3	9.0	35.7
1 1/8	28.60	46	51	33.3	36	47.6	12.0	1.3	9.2	45.5
1 1/4	31.75	49	54	33.3	39	50.8	12.0	1.3	9.2	45.5
1 3/8	34.92	54	59	33.3	42	53.9	12.0	1.3	9.2	45.5
1 1/2	38.10	59	64	33.3	45	57.1	12.0	1.3	9.2	45.5
1 5/8	41.27	61	66	33.3	48	60.3	12.0	1.3	9.2	45.5
1 3/4	44.45	64	69	40.5	52	63.5	12.0	1.3	9.2	52.5
1 7/8	47.62	66	71	40.5	55	66.7	12.0	1.3	9.2	52.5
2	50.80	69	74	40.5	58	69.8	13.5	1.3	10.7	54.0
2 1/8	53.97	78	83	41.0	62	73.1	13.5	1.3	10.7	54.5
2 1/4	57.15	80	85	41.0	65	76.2	13.5	1.3	10.7	54.5
2 3/8	60.32	83	88	41.0	68	79.4	13.5	1.3	10.7	54.5
2 1/2	63.50	85	90	41.0	71	82.5	13.5	1.3	10.7	54.5
2 5/8	66.68	90	95	49.0	78	92.1	15.9	1.3	13.2	64.9
2 3/4	69.85	95	100	49.0	81	95.2	15.9	1.3	13.2	64.9
2 7/8	73.03	99	104	49.0	84	98.4	15.9	1.3	13.2	64.9
3	76.20	99	104	49.0	88	101.6	15.9	1.3	13.2	64.9
3 1/8	79.38	104	109	56.0	94	111.1	20.0	1.3	17.2	76.0
3 1/4	82.55	109	114	56.0	97	114.3	20.0	1.3	17.2	76.0
3 3/8	85.73	109	114	56.0	100	117.5	20.0	1.3	17.2	76.0
3 1/2	88.90	114	119	56.0	103	120.6	20.0	1.3	17.2	76.0
3 5/8	92.08	119	124	59.0	106	123.8	20.0	1.3	17.2	79.0
3 3/4	95.25	119	124	59.0	109	127.0	20.0	1.3	17.2	79.0
3 7/4	98.43	124	129	62.0	113	130.2	20.0	1.3	17.2	82.0
4	101.60	124	129	62.0	116	133.3	20.0	1.3	17.2	82.0

Dimensions subject to changes or modifications.

DIMENSIONS CHART LRB04 / LRB04A

Dimensions in mm

Shaft mm	Rotary part				Stationary part						Total length
	d ₃	d ₄	l ₃	l _{3A}	d ₆	d ₇	l ₄	l _{4A}	l ₅	l ₆	
10	20	25	23.9	--	17	21	8.6	--	1.5	4	32.5
12	22	27	23.9	26	19	23	8.6	6.5	1.5	4	32.5
14	24	29	26.4	--	21	25	8.6	--	1.5	4	35.0
16	26	31.5	26.4	24.7	23	27	8.6	10.3	1.5	4	35.0
18	32	37	27.5	--	27	33	10.0	--	2.0	4	37.5
20	34	39.5	27.5	--	29	35	10.0	--	2.0	5	37.5
22	36	41	27.5	26.5	31	37	10.0	11	2.0	5	37.5
24	38	45	30.0	29.0	33	39	10.0	11	2.0	5	40.0
25	39	45	30.0	29.0	34	40	10.0	11	2.0	5	40.0
28	42	49.5	32.5	31.5	37	43	10.0	11	2.0	5	42.5
30	44	52	32.5	31.5	39	45	10.0	11	2.0	5	42.5
32	46	52	32.5	31.5	42	48	10.0	11	2.0	5	42.5
33	47	55.5	32.5	31.5	42	48	10.0	11	2.0	5	42.5
35	49	56.5	32.5	31.5	44	50	10.0	11	2.0	5	42.5
38	54	60	34.0	--	49	56	11.0	--	2.0	6	45.0
40	56	63	34.0	32.3	51	58	11.0	12.7	2.0	6	45.0
43	59	66.5	34.0	32.3	54	61	11.0	12.7	2.0	6	45.0
45	61	66.5	34.0	32.3	56	63	11.0	12.7	2.0	6	45.0
48	64	70.5	34.0	32.3	59	66	11.0	12.7	2.0	6	45.0
50	66	75	34.5	34.8	62	70	13.0	12.7	2.5	6	47.5
53	69	79	34.5	33.2	65	73	13.0	14.3	2.5	6	47.5
55	71	81	34.5	33.2	67	75	13.0	14.3	2.5	6	47.5
58	78	84	39.5	38.2	70	78	13.0	14.3	2.5	6	52.5
60	80	87	39.5	38.2	72	80	13.0	14.3	2.5	6	52.5
63	83	91	39.5	38.2	75	83	13.0	14.3	2.5	6	52.5
65	85	92	39.5	36.5	77	85	13.0	16	2.5	6	52.5
68	88	96.5	37.2	36.5	81	90	15.3	16	2.5	7	52.5
70	90	98	44.7	44.0	83	92	15.3	16	2.5	7	60.0
75	99	104	44.7	--	88	97	15.3	--	2.5	7	60.0
80	104	109	44.3	--	95	105	15.7	--	3.0	7	60.0
85	109	114	44.3	--	100	110	15.7	--	3.0	7	60.0
90	114	119	49.3	--	105	115	15.7	--	3.0	7	65.0
95	119	124	49.3	--	110	120	15.7	--	3.0	7	65.0
100	124	129	49.3	--	115	125	15.7	--	3.0	7	65.0

Dimensions subject to changes or modifications.

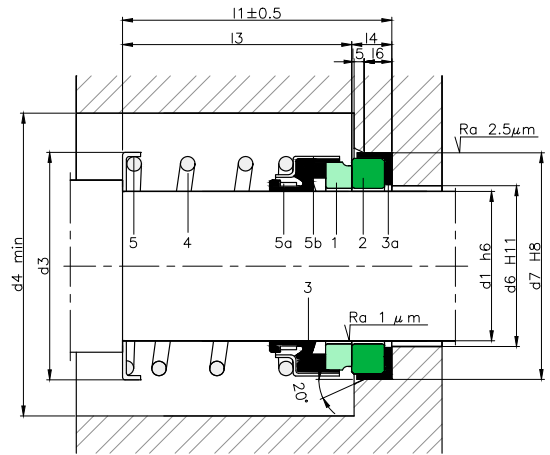

DIMENSIONS CHART LRB06

Dimensions in mm

Shaft mm	Rotary part			Stationary part					Total length
	d ₃	d ₄	l ₃	d ₆	d ₇	l ₄	l ₅	l ₆	
10	20	25	25.4	16.0	24.6	8.7	1.5	7.5	34.1
12	22	27	25.4	19.0	27.8	8.7	1.5	7.5	34.1
13	24	29	25.4	19.0	27.8	8.7	1.5	7.5	34.1
14	24	29	25.4	22.2	30.9	10.3	1.5	7.5	35.7
15	26	31	25.4	22.2	30.9	10.3	1.5	7.5	35.7
16	26	31	25.4	22.2	30.9	10.3	1.5	7.5	35.7
18	32	37	25.4	25.4	34.1	10.3	1.5	7.5	35.7
19	34	39	25.4	25.4	34.1	10.3	1.5	7.5	35.7
20	34	39	25.4	27.0	35.7	10.3	1.5	7.5	35.7
22	36	41	25.4	28.6	37.3	10.3	1.5	7.5	35.7
24	38	43	25.4	31.7	40.5	10.3	1.5	7.5	35.7
25	39	44	25.4	31.7	40.5	10.3	1.5	7.5	35.7
28	42	47	33.3	35.7	47.6	12.0	2.0	8.5	45.3
30	44	49	33.3	38.9	50.8	12.0	2.0	8.5	45.3
32	46	51	33.3	38.9	50.8	12.0	2.0	8.5	45.3
33	47	52	33.3	42.1	54.0	12.0	2.0	8.5	45.3
34	49	54	33.3	42.1	54.0	12.0	2.0	8.5	45.3
35	49	54	33.3	42.1	54.0	12.0	2.0	8.5	45.3
38	54	59	33.3	45.2	57.2	12.0	2.0	8.5	45.3
40	56	61	33.3	48.8	60.3	12.0	2.0	8.5	45.3
42	59	64	40.5	51.6	63.5	12.0	2.0	8.5	52.5
43	59	64	40.5	51.6	63.5	12.0	2.0	8.5	52.5
44	61	66	40.5	51.6	63.5	12.0	2.0	8.5	52.5
45	61	66	40.5	51.6	63.5	12.0	2.0	8.5	52.5
48	64	69	40.5	54.8	66.7	12.0	2.0	8.5	52.5
50	66	71	40.5	58.0	69.8	12.0	2.0	8.5	52.5
53	69	74	41.0	62.0	73.0	13.5	2.0	10.0	54.5
55	71	76	41.0	65.0	76.2	13.5	2.0	10.0	54.5
58	78	83	41.0	68.0	79.4	13.5	2.0	10.0	54.5
60	80	85	41.0	68.0	79.4	13.5	2.0	10.0	54.5
63	83	88	41.0	71.2	82.5	13.5	2.0	10.0	54.5
65	85	90	49.0	78.3	92.1	15.9	2.0	12.0	64.9
70	90	95	49.0	81.1	95.5	15.9	2.0	12.0	64.9
75	99	104	49.0	88.1	101.6	15.9	2.0	12.0	64.9
80	104	109	56.0	97.0	114.3	20.0	2.0	16.5	76.0
85	109	114	56.0	100.0	117.5	20.0	2.0	16.5	76.0
90	114	119	59.0	107.0	123.8	20.0	2.0	16.5	79.0
95	119	124	59.0	110.0	127.0	20.0	2.0	16.5	79.0
100	124	129	62.0	116.0	133.3	20.0	2.0	16.5	82.0

Dimensions subject to changes or modifications.

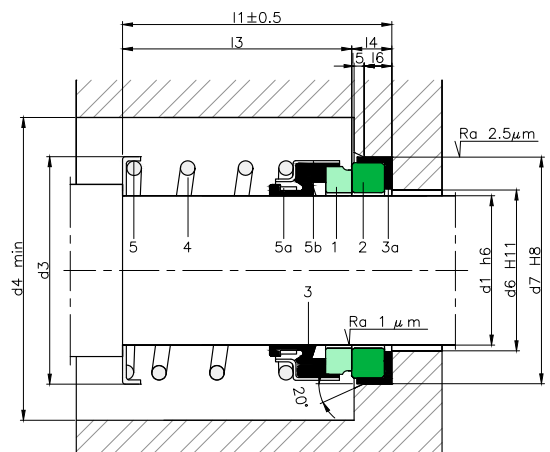

LRB02



COMPONENTS:

- 1 Rotating contact surface
- 2 Stationary contact surface
- 3 Bellows
- 3a Elastomeric cup
- 4 Spring
- 5 Metal frame

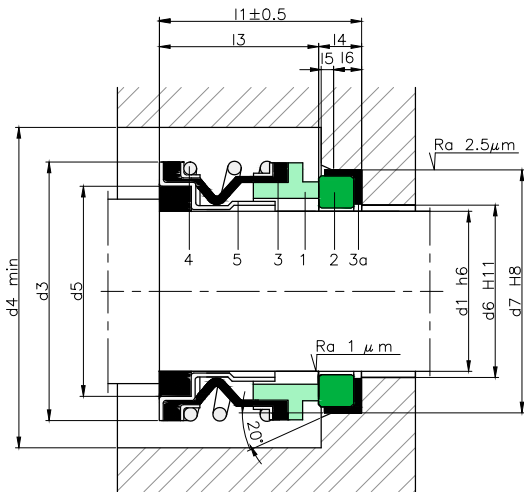

SECTORS:



CHARACTERISTICS:

- Unbalanced.
- Not dependent on the rotation direction.
- Single cylindrical spring.

OPERATING LIMITS:

$d_1 = 9.52 \div 25.40 \text{ mm}$ $p = 7 \text{ kg/cm}^2$

$v = 10 \text{ m/s}$ $t = -15 \div +200^\circ\text{C} (*)$

(*) The temperature resistance depends on the material of the secondary seals used.

The operating limits are defined by the PV factor which is determined for the sealing system characteristics and those of the application.

DESCRIPTION:

Seal with a compact design for applications with low demands that require small diameters and often used for water pumps.

DIMENSIONS CHART

Dimensions in inches

Shaft (")	mm	Rotary part				Stationary part					Total length l_1
		d_3	d_4	d_5	l_3	d_6	d_7	l_4	l_5	l_6	
3/8	9.52	23.80	28.80	17.46	16.00	14.3	22.22	6.2	1.3	5.1	22.2
1/2	12.70	26.97	31.97	20.63	18.30	17.5	25.40	8.0	1.3	5.1	26.3
5/8	15.88	30.94	35.94	23.81	18.70	20.6	31.75	10.3	1.3	7.5	29.0
3/4	19.05	34.11	39.11	26.98	18.70	23.8	34.93	10.3	1.3	7.5	29.0
1	25.40	42.85	47.85	33.33	20.60	30.2	41.28	11.0	1.3	7.5	31.6

Dimensions subject to changes or modifications.

LRB03 - LRB03A - LRB03B



TYPE LRB03

COMPONENTS:

- 1 Rotating contact surface
- 2 Stationary contact surface
- 3 Bellows
- 3a Elastomeric cup
- 4 Spring
- 5 Metal frame

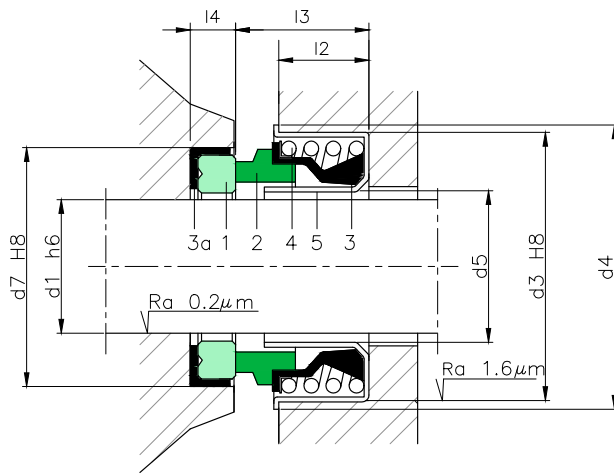

SECTORS:



CHARACTERISTICS:

- Unbalanced.
- Not dependent on the rotation direction.
- Single cylindrical spring.

OPERATING LIMITS:

$d_1 = 10 \div 30 \text{ mm}$ $p = 6 \text{ kg/cm}^2$
 $v = 10 \text{ m/s}$ $t = -20 \div +100^\circ\text{C} (*)$

(*) The temperature resistance depends on the material of the secondary seals used.

The operating limits are defined by the PV factor which is determined for the sealing system characteristics and those of the application.

DESCRIPTION:

Mechanical seal with a compact design and small dimensions which is ideal for simple hydromassage or drinking water pumps. The rotating part is attached to the pump impeller, rotates together with it. The stationary part is secured to the housing on its external diameter.

DIMENSIONS CHART LRB03

Dimensions in mm

Shaft		Rotary part		Stationary part				
(")	mm	d ₇	l ₄	d ₃	d ₄	d ₅	l ₂	l ₃
1/2	13	25.0	7.5	28.5	32.0	14.5	8.0	13.2
1/2 B	13	25.0	5.0	28.5	32.0	14.5	8.0	13.2
1/2 C	13	25.0	5.0	30.0	34.5	14.0	7.5	13.2
5/8	16	31.7	10.0	36.5	41.0	17.5	8.5	16.3
5/8 B	16	31.0	5.0	36.5	41.0	17.5	8.5	16.3
3/4	19	35.0	10.0	40.0	43.0	21.5	9.5	16.0
3/4 B	19	35.0	5.0	40.0	43.0	21.5	9.5	16.0
1	25	41.0	11.0	47.0	51.0	26.5	11.0	18.0
1 1/8	29	48.0	8.5	52.0	57.0	31.0	11.0	18.5

Dimensions subject to changes or modifications.

LRB03A



TYPE LRB03A

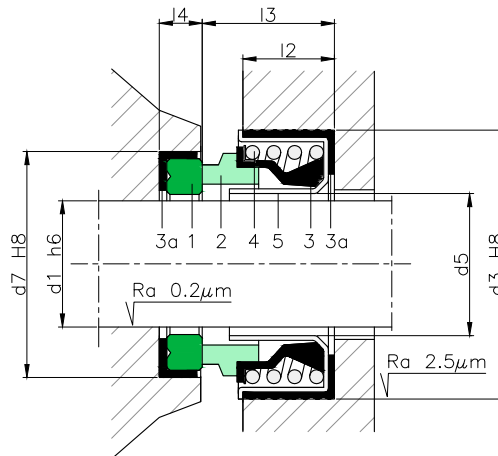

DIMENSIONS CHART LRB03A

Dimensions in mm

Shaft mm	Rotary part		Stationary part			
	d_7	l_4	d_3	d_5	l_2	l_3
10	23.0	4	27	11.0	7.5	14.0
12	25.0	5	32	14.2	8.5	14.2
16	31.0	5	41	18.2	10.0	16.8
20	35.0	5	45	21.4	10.0	17.5
25	41.3	11	52	26.4	11.5	20.0
30	48.0	8	58	31.0	12.5	21.0

Dimensions subject to changes or modifications.

LRB03B



TYPE LRB03B

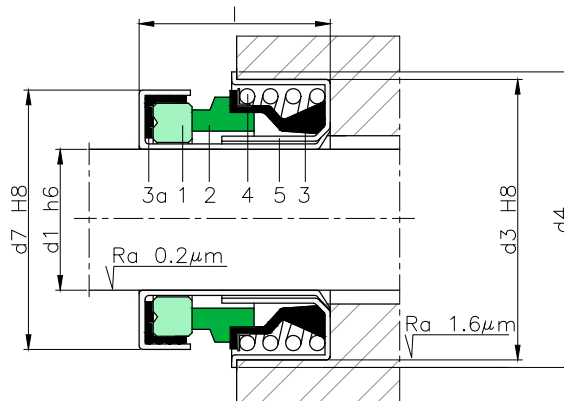

DIMENSIONS CHART LRB03B

Dimensions in mm

Shaft mm	Rotary part		Stationary part		
	d_3	d_4	d_7	l	
12	12.0	30.00	35.0	25.0	17.7
12 B	12.0	28.55	32.0	25.0	17.7
12 C	12.0	33.40	38.0	25.0	17.5
13	13.0	30.00	35.0	25.0	17.7
15	15.0	36.50	41.5	30.0	20.0
16	16.0	36.50	41.5	30.0	20.0
16 B	16.0	38.10	41.3	28.5	20.0
20	20.0	40.00	43.7	37.0	22.0
20 B	20.0	38.00	43.7	37.0	22.0

Dimensions subject to changes or modifications.

LRB05



COMPONENTS:

- 1 Rotating contact surface
- 2 Stationary contact surface
- 3 Bellows
- 3a Elastomeric cup
- 4 Spring
- 5 Ring
- 5a Drive ring
- 5b Metal frame

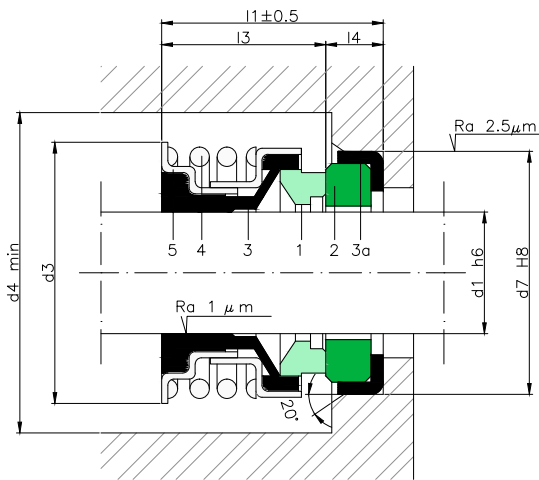

SECTORS:



CHARACTERISTICS:

- Unbalanced.
- Not dependent on the rotation direction.
- Single cylindrical spring.

OPERATING LIMITS:

$d_1 = 12 \div 25.4 \text{ mm}$ $p = 7 \text{ kg/cm}^2$
 $v = 10 \text{ m/s}$ $t = -20 \div +100^\circ\text{C}$ (*)

(*) The temperature resistance depends on the material of the secondary seals used.

The operating limits are defined by the PV factor which is determined for the sealing system characteristics and those of the application.

DESCRIPCIÓN:

Mechanical seal with a simple design for general use.

DIMENSIONS CHART

Dimensions in mm

Shaft (")	mm	Rotary part			Stationary part		Total length l_1
		d_3	d_4	l_3	d_7	l_4	
12.00	23.30	28.30	16.30	24	4.5	20.8	
14.00	30.40	35.40	18.60	30	8.5	27.1	
5/8	15.88	30.40	35.40	18.60	30	27.1	
3/4	19.05	33.00	38.0	17.70	35	28.0	
7/8	22.20	36.30	41.30	20.60	38	30.9	
1	25.40	39.40	44.40	20.70	41.3	31.7	

Dimensions subject to changes or modifications.

LRB17 - LRB17A- LRB17E - LRB17KU - LRB17NU

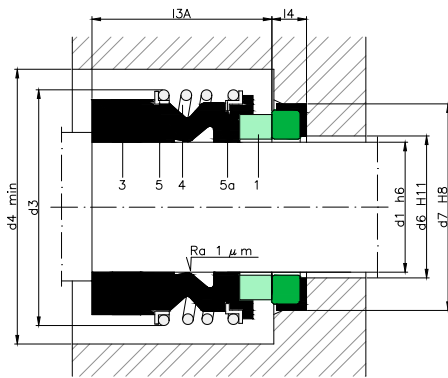

TYPE LRB17A

COMPONENTS:

- 1 Rotating contact surface
- 3 Bellows
- 4 Spring
- 5 Ring
- 5a Ring

SECTORS:



CHARACTERISTICS:

- Unbalanced.
- Not dependent on the rotation direction.
- Single cylindrical spring.

OPERATING LIMITS:

$d_1 = 10 \div 100 \text{ mm}$ $p = 12 \text{ kg/cm}^2$
 $v = 10 \text{ m/s}$ $t = -15 \div +200^\circ\text{C} (*)$

(*) The temperature resistance depends on the material of the secondary seals used.

The operating limits are defined by the PV factor which is determined for the sealing system characteristics and those of the application.

DESCRIPTION:

A versatile, robust single seal that is widely used in many different industrial and household applications. The different type LRB17 varieties can be combined with a wide range of stationary parts, thereby increasing its versatility due to the combination of different materials and working lengths. Types: LRB17KU-L6 / LRB17KU-L60 : standardised dimensions in accordance with standard EN 12756 (KU). LRB17NU -L6 / LRB17NU-L60 : standardised dimensions in accordance with standard EN 12756 (NU).

DIMENSIONS CHART LRB17A
 Dimensions in mm

Shaft mm	Rotary part				Stationary part		
	d ₁	d ₃	d ₄	l _{3A}	d ₆	d ₇	l ₄
15	15	28	33	17	29	35	4
20	20	37	42	21.5	29	35	7.5
25	25	41	46	23	34	40	7.5
30	30	48	53	24	45	51	9.5
45	45	65	70	30	58	65	12.5
55	55	80	85	43	67	76.5	14

Dimensions subject to changes or modifications.

DIMENSIONS CHART LRB17 - LRB17E - LRB17KU- LRB17NU

Dimensions in mm

Shaft mm	Rotary part						Stationary part																						
	d ₃	d ₄	l ₃	l _{3E}	l _{3KU}	l _{3NU}	d ₆	d ₇	d ₈	d ₁₁	d ₁₂	d ₁₄	d ₁₆	l ₅	l ₆	l ₇	l ₈	l ₉	l ₁₀	l ₁₁	l ₁₂	l ₁₃	l ₁₄	l ₁₅	l ₁₆	l ₁₇	l ₂₈	l ₂₉	
10	22.5	25.0	14.5	25	25.9	33.4	17	21	3	15.5	19.2	11.0	24.60	1.5	4	8.5	17.5	10.0	7.5	--	7.5	--	6.6	1.2	3.8	7.5	6.6	9.0	
12	25.0	27.5	15.0	25	25.9	33.4	19	23	3	17.5	21.6	13.5	27.80	1.5	4	8.5	17.5	10.0	7.5	--	6.5	--	5.6	1.2	3.8	7.5	6.6	9.0	
14	28.5	32.0	17.0	25	28.4	33.4	21	25	3	20.5	24.6	17.0	30.95	1.5	4	8.5	17.5	10.0	7.5	--	6.5	--	5.6	1.2	3.8	9.0	6.6	10.5	
15	28.5	32.0	17.0	25	--	--	--	--	--	20.5	24.6	17.0	30.95	--	--	--	--	--	--	--	--	7.5	--	6.6	1.2	3.8	9.0	--	10.5
16	28.5	32.0	17.0	25	28.4	33.4	23	27	3	22.0	28.0	17.0	30.95	1.5	4	8.5	17.5	10.0	7.5	--	8.5	--	7.5	1.5	5.0	9.0	6.6	10.5	
18	32.0	34.5	19.5	25	30.0	37.5	27	33	3	24.0	30.0	20.0	34.15	2.0	5	9.0	19.5	11.5	8.5	12.5	9.0	10.0	8.0	1.5	5.0	9.0	7.5	10.5	
20	37.0	39.5	21.5	25	30.0	37.5	29	35	3	29.5	35.0	21.5	35.70	2.0	5	9.0	19.5	11.5	8.5	12.5	8.5	9.5	7.5	1.5	5.0	9.0	7.5	10.5	
22	37.0	39.5	21.5	25	30.0	37.5	31	37	3	29.5	35.0	23.0	37.30	2.0	5	9.0	19.5	11.5	8.5	12.5	8.5	9.5	7.5	1.5	5.0	9.0	7.5	10.5	
24	42.5	45.0	22.5	25	32.5	42.5	33	39	3	32.0	38.0	26.5	40.50	2.0	5	9.0	19.5	11.5	8.5	12.5	8.5	9.5	7.5	1.5	5.0	9.0	7.5	10.5	
25	42.5	45.0	23.0	25	32.5	42.5	34	40	3	32.0	38.0	26.5	40.50	2.0	5	9.0	19.5	11.5	8.5	12.5	8.5	9.5	7.5	1.5	5.0	9.0	7.5	10.5	
28	49.0	51.5	26.5	33	35.0	42.5	37	43	3	36.0	42.0	29.5	47.65	2.0	5	9.0	19.5	11.5	8.5	14.0	10.0	11.0	9.0	1.5	5.0	10.5	7.5	12.0	
30	49.0	51.5	26.5	33	35.0	42.5	39	45	3	39.2	45.0	32.5	50.80	2.0	5	9.0	19.5	11.5	8.5	14.0	11.5	11.0	10.5	1.5	5.0	10.5	7.5	12.0	
32	53.5	56.0	27.5	33	35.0	47.5	42	48	3	42.2	48.0	32.5	50.80	2.0	5	9.0	19.5	11.5	8.5	14.0	11.5	11.0	10.5	1.5	5.0	10.5	7.5	12.0	
33	53.5	56.0	27.5	33	35.0	47.5	42	48	3	44.2	50.0	36.5	54.00	2.0	5	9.0	19.5	11.5	8.5	14.5	12.0	11.5	11.0	1.5	5.0	10.5	7.5	12.0	
35	57.0	59.5	28.5	33	35.0	47.5	44	50	3	46.2	52.0	36.5	54.00	2.0	5	9.0	19.5	11.5	8.5	14.5	12.0	11.5	11.0	1.5	5.0	10.5	7.5	12.0	
38	59.0	61.5	30.0	33	36.0	46.0	49	56	4	49.2	55.0	39.5	57.15	2.0	6	9.0	22.0	14.0	10.0	14.5	11.3	11.5	10.3	1.5	5.0	10.5	9.0	12.0	
40	62.0	64.5	30.0	33	36.0	46.0	51	58	4	52.2	58.0	42.5	60.35	2.0	6	9.0	22.0	14.0	10.0	14.5	11.8	11.5	10.8	1.5	5.0	10.5	9.0	12.0	
43	65.5	68.0	30.0	41	36.0	51.0	54	61	4	53.3	62.0	46.0	63.50	2.0	6	9.0	22.0	14.0	10.0	17.0	13.2	14.3	12.0	2.0	6.0	10.5	9.0	12.0	
45	68.0	70.5	30.0	41	36.0	51.0	56	63	4	55.3	64.0	46.0	63.50	2.0	6	9.0	22.0	14.0	10.0	17.0	12.8	14.3	11.6	2.0	6.0	10.5	9.0	12.0	
48	70.5	73.0	30.5	41	36.0	51.0	59	66	4	59.7	68.4	49.0	66.70	2.0	6	9.0	22.0	14.0	10.0	17.0	12.8	14.3	11.6	2.0	6.0	10.5	9.0	12.0	
50	74.0	74.5	30.5	41	38.0	50.5	62	70	4	60.8	69.3	52.0	69.85	2.5	6	9.0	23.0	15.0	10.5	17.0	12.8	14.3	11.6	2.0	6.0	12.0	9.5	13.5	
53	78.5	82.5	33.0	41	36.5	59.0	65	73	4	63.8	72.3	55.5	73.05	2.5	6	9.0	23.0	15.0	12.0	17.0	13.5	14.3	12.3	2.0	6.0	12.0	11.0	13.5	
55	81.0	85.5	35.0	41	36.5	59.0	67	75	4	66.5	75.4	58.5	76.20	2.5	6	9.0	23.0	15.0	12.0	18.0	14.5	15.3	13.3	2.0	6.0	12.0	11.0	13.5	
58	85.5	89.5	37.0	41	41.5	59.0	70	78	4	69.5	78.4	61.5	79.40	2.5	6	9.0	23.0	15.0	12.0	18.0	14.5	15.3	13.3	2.0	6.0	12.0	11.0	13.5	
60	85.5	92.5	38.0	41	41.5	59.0	72	80	4	71.5	80.4	61.5	79.40	2.5	6	9.0	23.0	15.0	12.0	18.0	14.5	15.3	13.3	2.0	6.0	12.0	11.0	13.5	
65	93.5	97.5	40.0	49	41.5	69.0	77	85	4	76.5	85.4	68.0	92.10	2.5	6	9.0	23.0	15.0	12.0	18.0	14.2	15.3	13.0	2.0	6.0	14.5	11.0	16.0	
68	96.5	100.5	40.0	49	41.2	68.7	81	90	4	82.7	91.5	71.0	95.25	2.5	7	9.0	26.2	18.0	12.5	19.0	14.9	16.0	13.7	2.0	6.0	14.5	11.3	16.0	
70	99.5	103.5	40.0	49	48.7	68.7	83	92	4	83.0	92.0	71.0	95.25	2.5	7	9.0	26.2	18.0	12.5	18.0	14.2	15.3	13.0	2.0	6.0	14.5	11.3	16.0	
75	107.0	111.0	40.0	52	48.7	68.7	88	97	4	90.2	99.0	77.5	101.60	2.5	7	9.0	26.2	18.0	12.5	18.0	15.2	15.3	14.0	2.0	6.0	14.5	11.3	16.0	
80	112.0	116.0	40.0	56	48.0	78.0	95	105	4	95.2	104.0	84.0	114.30	3.0	7	9.0	26.2	18.2	13.0	19.0	16.2	16.3	15.0	2.0	6.0	18.5	12.0	20.0	
85	120.0	124.0	41.0	56	46.0	76.0	100	110	4	100.2	109.0	87.0	117.50	3.0	7	9.0	26.2	18.2	15.0	19.0	16.0	16.3	14.8	2.0	6.0	18.5	14.0	20.0	
90	127.0	131.0	45.0	59	51.0	76.0	105	115	4	105.2	114.0	93.5	123.85	3.0	7	9.0	26.2	18.2	15.0	19.0	16.0	16.3	14.8	2.0	6.0	18.5	14.0	20.0	
95	132.0	136.0	46.0	59	51.0	76.0	110	120	4	111.6	120.3	96.5	127.00	3.0	7	9.0	25.2	17.2	15.0	20.0	17.0	17.3	15.8	2.0	6.0	18.5	14.0	20.0	
100	137.0	141.0	47.0	59	51.0	76.0	115	125	4	114.5	123.3	103.0	133.35	3.0	7	9.0	25.2	17.2	15.0	20.0	17.0	17.3	15.8	2.0	6.0	18.5	14.0	20.0	

Dimensions subject to changes or modifications.

The usual stationary part types:

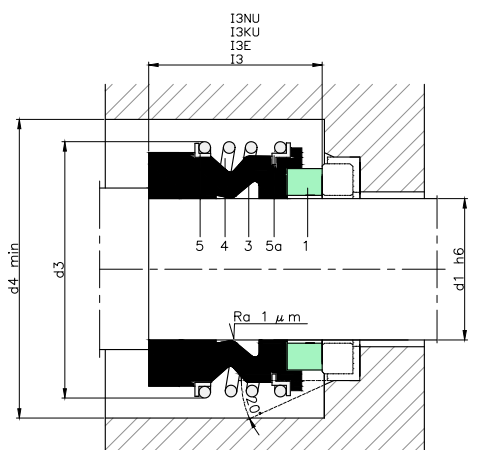

TYPE LRB17 - TYPE LRB17E - TYPE LRB17KU - TYPE LRB17NU

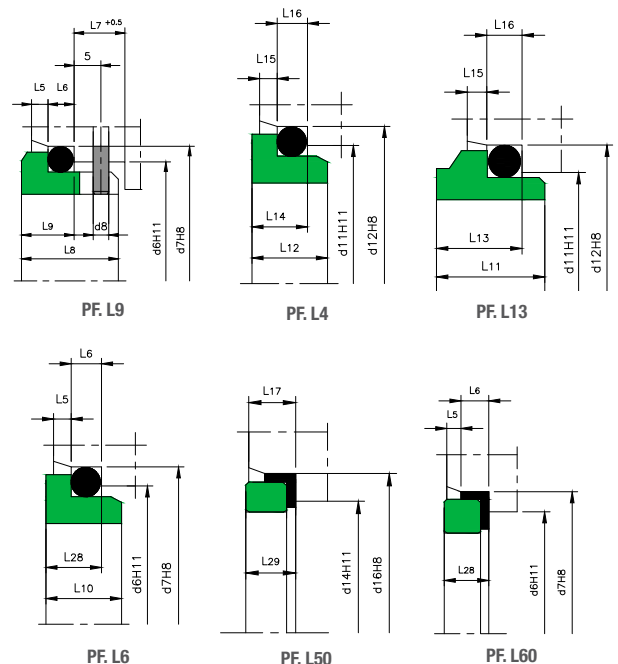

Tolerances l₁, d₁, 10... 12 mm ± 0.5; 14... 18 mm ± 1.0; 20... 25 mm ± 1.5; 28... 100 mm ± 2.0

LRB25-R - LRB25KU-R and LRB25NU-R

SECTORS:



CHARACTERISTICS:

- **Balanced.**
- **Not dependent on the rotation direction.**
- **Single cylindrical spring.**

OPERATING LIMITS:

$$d_1 = 10 \div 100 \text{ mm} \quad p = 20 \text{ kg/cm}^2$$

$$v = 15 \text{ m/s} \quad t = -15 \div +200^\circ\text{C} (*)$$

(*) The temperature resistance depends on the material of the secondary seals used.

The operating limits are defined by the PV factor which is determined for the sealing system characteristics and those of the application.

DESCRIPTION:

An extremely versatile general-use mechanical seal. It has metal tabs that reduce fatigue and tension in the rubber bellows when in the working position. A balanced seal without the need for a stepped shaft. The seal can operate in applications with high pressures without suffering premature wear.

Types:

LRB25KU-R and LRB25NU-R: standardised dimensions in accordance with standard EN 12756 (KU and NU respectively).



COMPONENTS:

- 1 Rotating contact surface
- 2 Stationary contact surface
- 3 Bellows
- 3a Elastomeric cup
- 4 Spring
- 5 Ring
- 5a Metal frame

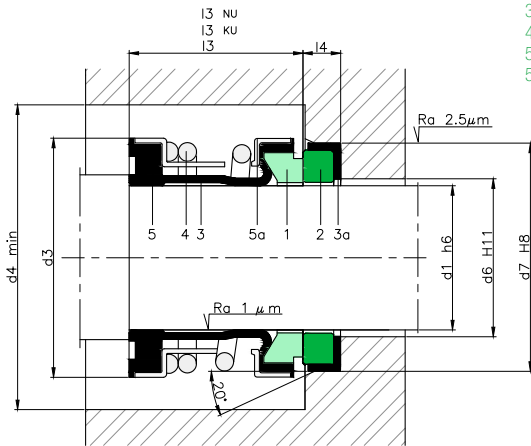

DIMENSIONS CHART

Dimensions in mm

Shaft	Rotary part					Stationary part		
	d ₃	d ₄	l ₃	l _{3KU}	l _{3NU}	d ₆	d ₇	l ₄
10	20	22	15	27.5	35.0	15	21	5.0
12	22	24	15	26.5	34.0	17	23	6.0
14	24	26	15	29.0	34.0	19	25	6.0
15	25	27	15	29.0	34.0	20	26	6.0
16	26	28	15	29.0	34.0	23	27	6.0
18	32	34	20	31.5	39.0	25	33	6.0
20	34	36	20	31.5	39.0	27	35	6.0
22	36	38	20	31.5	39.0	29	37	6.0
24	38	40	20	34.0	44.0	31	39	6.0
25	39	41	20	34.0	44.0	32	40	6.0
28	42	44	26	36.5	44.0	35	43	6.0
30	44	46	26	35.5	43.0	37	45	7.0
32	46	48	26	35.5	48.0	40	48	7.0
33	47	49	26	35.5	48.0	40	48	7.0
35	49	51	26	34.5	47.0	42	50	8.0
38	54	58	30	37.0	47.0	47	56	8.0
40	56	60	30	37.0	47.0	49	58	8.0
43	59	63	30	37.0	52.0	52	61	8.0
45	61	65	30	37.0	52.0	54	63	8.0
48	64	68	30	35.0	50.0	57	66	10.0
50	66	70	30	37.5	50.0	60	70	10.0
53	69	73	30	37.5	50.0	63	73	10.0
55	71	75	30	37.5	50.0	65	75	10.0
58	78	83	33	42.5	60.0	68	78	10.0
60	80	85	33	40.5	58.0	70	80	12.0
63	83	88	33	40.5	58.0	73	83	12.0
65	85	90	33	40.5	68.0	75	85	12.0
68	88	93	33	40.5	68.0	79	90	12.0
70	90	95	33	48.0	68.0	81	92	12.0
75	99	104	40	48.0	68.0	86	97	12.0
80	104	109	40	47.5	77.5	92	105	12.5
85	109	114	40	47.5	77.5	97	110	12.5
90	114	119	40	52.5	77.5	102	115	12.5
95	119	124	40	52.5	77.5	117	120	12.5
100	124	129	40	52.5	77.5	122	125	12.5

Dimensions subject to changes or modifications.

Dimensions in inches

Shaft	Rotary part			Stationary part		
	(")	mm	d ₃	d ₄	l ₃	d ₇
0,375	9,53	20	22	15	22,23	7,9
0,500	12,70	24	26	15	25,40	7,9
0,625	15,88	26	28	15	31,75	10,3
0,750	19,05	32	34	20	34,93	10,3
0,875	22,23	36	38	20	38,10	10,3
1,000	25,40	39	41	20	41,28	11,1
1,125	28,58	42	44	26	44,45	11,1
1,250	31,75	46	48	26	47,63	11,1
1,375	34,93	49	51	26	50,80	11,1
1,500	38,10	54	58	30	53,98	11,1
1,625	41,28	56	60	30	60,33	12,7
1,750	44,45	61	65	30	63,50	12,7
1,875	47,63	64	68	30	66,68	12,7
2,000	50,80	66	70	30	69,85	12,7
2,125	53,98	69	73	30	76,20	14,3
2,250	57,15	78	83	33	79,38	14,3
2,375	60,33	80	85	33	82,55	14,3
2,500	63,50	83	88	33	85,73	14,3
2,625	66,68	88	93	33	85,73	15,9
2,750	69,85	90	95	33	88,90	15,9
2,875	73,03	96	101	33	95,25	15,9
3,000	76,20	99	104	40	98,43	15,9
3,125	79,38	103	108	40	101,60	19,8
3,250	82,55	104	109	40	104,78	19,8
3,375	85,73	108	114	40	107,95	19,8
3,500	88,90	112	117	40	111,13	19,8
3,625	92,08	114	119	40	114,30	19,8
3,750	95,25	118	124	40	117,48	19,8
3,875	98,43	122	127	40	120,65	19,8
4,000	101,60	124	129	40	123,83	19,8

AR / LRB31



COMPONENTS:

- 1 Rotating contact surface
- 2 Stationary contact surface
- 3 Bellows
- 3a Elastomeric cup
- 4 Spring
- 5 Ring
- 5a Blocking ring
- 5b Metal frame

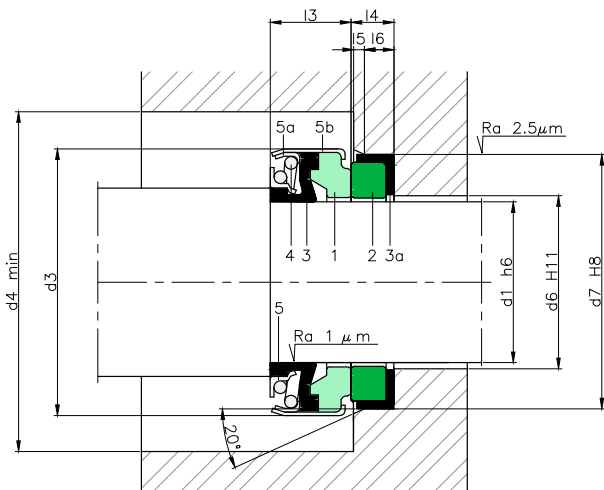

SECTORS:



CHARACTERISTICS:

- Unbalanced.
- Not dependent on the rotation direction.
- Single cylindrical spring.

OPERATING LIMITS:

$d_1 = 6 \div 70 \text{ mm}$ $p = 6 \text{ kg/cm}^2$
 $v = 10 \text{ m/s}$ $t = -20 \div +140^\circ\text{C}$ (*)

(*) The temperature resistance depends on the material of the secondary seals used.

The operating limits are defined by the PV factor which is determined for the sealing system characteristics and those of the application.

DESCRIPTION:

Economic mechanical seal with small dimensions, used in large household pump productions for re-circulating water or for working conditions with low demands.

DIMENSIONS CHART

Dimensions in mm

Shaft mm	Rotary part				Stationary part				
	d ₃	d ₄	l ₃		d ₆	d ₇	l ₄	l ₅	l ₆
6	18	23	8.0	+0.5	8	22.0	4.0	0.5	3.5
6 A	18	23	11.0	+0.5	8	22.0	4.0	0.5	3.5
8	20	23	11.0	+0.5	10	22.0	4.0	0.5	3.5
8 A	20	27	11.0	+0.5	10	26.0	5.5	1.0	5.0
8 B	24	27	11.0	+0.5	10	26.0	8.0	1.0	6.0
10	24	27	11.0	+0.5	12	26.0	8.0	1.0	6.0
11	24	27	11.0	+0.5	13	26.0	8.0	1.0	6.0
11 A	24	27	13.0	+0.5	13	26.0	8.0	1.0	6.0
12 A	24	27	11.0	+0.5	14	26.0	8.0	1.0	6.0
12 B	24	27	12.8	+0.7	14	26.0	8.0	1.0	6.0
12 C	24	27	13.0	+0.7	14	26.0	5.5	1.0	6.0
13	24	27	12.8	+0.7	15	26.0	8.0	1.0	6.0
13 A	24	27	13.0	+0.7	15	26.0	5.5	1.0	6.0
14 A	32	35	12.8	+0.7	16	29.5	8.0	1.0	6.0
14 B	28	30	12.8	+0.7	18	28.5	7.5	1.0	5.5
14 C	28	30	13.0	+0.7	18	28.5	8.0	1.0	5.5
15	32	35	12.8	+0.7	17	29.5	8.0	1.0	6.0
15 A	28	35	13.0	+0.7	17	30.0	8.0	1.0	6.0
16 A	32	35	12.8	+0.7	18	29.5	8.0	1.0	6.0
16 B	39	43	12.8	+0.7	18	38.0	8.0	1.0	6.0
17	39	43	12.8	+0.7	19	42.0	8.0	1.0	6.0
18	39	43	12.8	+0.7	20	42.0	8.0	1.0	6.0
19	39	43	12.8	+0.7	21	42.0	8.0	1.0	6.0
20 A	39	43	12.8	+0.7	22	42.0	8.0	1.0	6.0
20 B	42	47	12.8	+0.7	22	45.0	10.0	1.0	8.0
22	42	47	12.8	+0.7	24	45.0	10.0	1.0	8.0
22 A	39	47	13.0	+0.7	24	42.0	8.0	1.0	8.0
23	47	52	13.5	+1.0	25	50.0	10.0	1.0	8.0
24	47	52	13.5	+1.0	26	50.0	10.0	1.0	8.0
25 A	42	52	13.5	+1.0	27	50.0	10.0	1.0	8.0
25 B	47	52	13.5	+1.0	27	50.0	10.0	1.0	8.0
25 C	42	52	13.0	+1.0	27	45.0	10.0	1.0	8.0
26	47	52	13.5	+1.0	29	50.0	10.0	1.0	8.0
27	47	52	13.5	+1.0	30	50.0	10.0	1.0	8.0
28	54	60	15.0	+1.0	31	57.0	10.0	1.0	8.0
30	54	60	15.0	+1.0	33	57.0	10.0	1.0	8.0
32	54	60	15.0	+1.0	35	57.0	10.0	1.0	8.0
35	60	70	16.0	+1.0	38	63.0	10.0	1.0	8.0
38	65	75	18.0	+1.0	41	68.0	12.0	2.0	9.0
40	65	75	18.0	+1.0	43	68.0	12.0	2.0	9.0
45	70	80	20.0	+1.0	48	73.0	12.0	2.0	9.0
50	85	95	23.0	+1.0	53	88.0	15.0	2.0	12.0
55	85	95	23.0	+1.0	55	88.0	15.0	2.0	12.0
60	105	115	30.0	+1.0	63	110.0	15.0	2.0	12.0
65	105	115	30.0	+1.0	68	110.0	15.0	2.0	12.0
70	105	115	32.0	+1.0	73	110.0	15.0	2.0	12.0

Dimensions subject to changes or modifications.

LRB50



COMPONENTS:

- 1 Rotating contact surface
- 2 Stationary contact surface
- 3 Bellows
- 3a O-rings
- 4 Spring
- 5 Ring
- 5a Metal frame

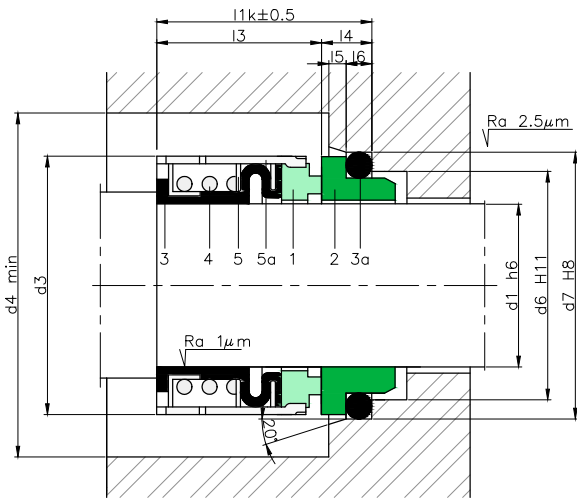

SECTORS:



CHARACTERISTICS:

- Balanced.
- Not dependent on the rotation direction.
- Single cylindrical spring.

OPERATING LIMITS:

$d_1 = 14 \div 100 \text{ mm}$ $p = 20 \text{ kg/cm}^2$
 $v = 15 \text{ m/s}$ $t = -15 \div +200^\circ\text{C}$ (*)

(*) The temperature resistance depends on the material of the secondary seals used.

The operating limits are defined by the PV factor which is determined for the sealing system characteristics and those of the application.

DESCRIPTION:

A balanced seal without the need for a stepped shaft. The casing of the rotating part protects the bellows from abrasion and from the rotation transmission tensions, and the spring from blocking in the event of being contaminated by fibres and particles. It is recommended for use with highly viscous or sticky fluids containing fibres or particles, or with fluids that produce a chemical attack on the shaft.

DIMENSIONS CHART

Dimensions in mm

Shaft mm	Rotary part			Stationary part					Total length
	d ₃	d ₄	l ₃	d ₆	d ₇	l ₄	l ₅	l ₆	
14	24	26	23.0	21	25	12.0	1.5	4	35.0
16	26	28	23.0	23	27	12.0	1.5	4	35.0
18	32	34	24.0	27	33	13.5	2.0	4	37.5
20	34	36	24.0	29	35	13.5	2.0	5	37.5
22	36	38	24.0	31	37	13.5	2.0	5	37.5
24	38	40	26.7	33	39	13.5	2.0	5	40.2
25	39	41	27.0	34	40	13.0	2.0	5	40.0
28	42	44	30.0	37	43	12.5	2.0	5	42.5
30	44	46	30.5	39	45	12.0	2.0	5	42.5
32	46	48	30.5	42	48	12.0	2.0	5	42.5
33	47	49	30.5	42	48	12.0	2.0	5	42.5
35	49	51	30.5	44	50	12.0	2.0	5	42.5
38	54	58	32.0	49	56	13.0	2.0	6	45.0
40	56	60	32.0	51	58	13.0	2.0	6	45.0
43	59	63	32.0	54	61	13.0	2.0	6	45.0
45	61	65	32.0	56	63	13.0	2.0	6	45.0
48	64	68	32.0	59	66	13.0	2.0	6	45.0
50	66	70	34.0	62	70	13.5	2.5	6	47.5
53	69	73	34.0	65	73	13.5	2.5	6	47.5
55	71	75	34.0	67	75	13.5	2.5	6	47.5
58	78	83	39.0	70	78	13.5	2.5	6	52.5
60	80	85	39.0	72	80	13.5	2.5	6	52.5
63	83	88	39.0	75	83	13.5	2.5	6	52.5
65	85	90	39.0	77	85	13.5	2.5	6	52.5
68	88	93	39.0	81	90	13.5	2.5	7	52.5
70	90	95	45.5	83	92	14.5	2.5	7	60.0
75	95	104	45.5	88	97	14.5	2.5	7	60.0
80	104	109	45.0	95	105	14.5	2.5	7	60.0
85	109	114	45.0	100	110	14.5	2.5	7	60.0
90	110	119	50.0	105	115	15.0	3.0	7	65.0
95	119	124	50.0	110	120	15.0	3.0	7	65.0
100	124	129	50.0	115	125	15.0	3.0	7	65.0

Dimensions subject to changes or modifications.

LTB16



COMPONENTS:

- 1 Rotating contact surface
- 2 Stationary contact surface
- 3 Bellows
- 3a PTFE gasket
- 4 Spring
- 5 Ring
- 5a Set screw

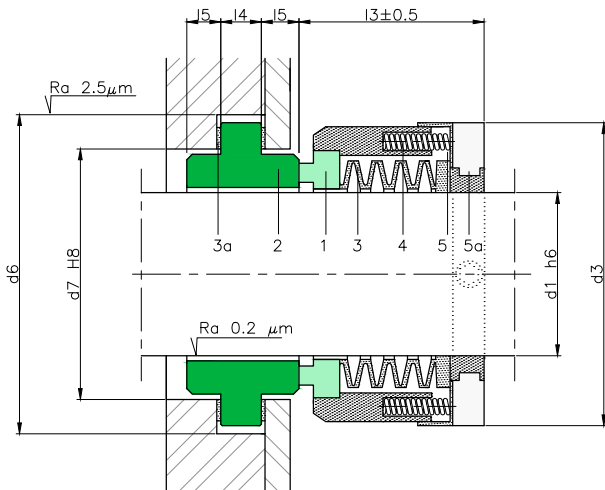

SECTORS:



CHARACTERISTICS:

- Unbalanced.
- Not dependent on the rotation direction.
- External mounting.

OPERATING LIMITS:

$d_1 = 25 \div 100 \text{ mm}$ $p = 12 \text{ kg/cm}^2$
 $v = 16 \text{ m/s}$ $t = -40 \div +200^\circ\text{C} (^{\circ})$

(*) The temperature resistance depends on the material of the secondary seals used.

The operating limits are defined by the PV factor which is determined for the sealing system characteristics and those of the application.

DESCRIPTION:

This mechanical seal model is mostly made of PTFE and other materials that are resistant to chemically aggressive products. The metal parts are isolated from the process fluid.

DIMENSIONS CHART

Dimensions in mm

Shaft mm	Rotary part		Stationary part			
	d ₃	l ₃	d ₆	d ₇	l ₄	l ₅
20	57	31	51	40.6	8	4.8
25	61	33	54	42.86	8.0	4.8
28	67	36	65	50.80	11.0	8.0
30	70	37	68	53.98	11.0	8.0
32	70	37	68	53.98	11.0	8.0
33	73	38	71	57.15	11.0	8.0
35	73	38	71	57.15	11.0	8.0
38	76	38	78	63.50	11.0	8.0
40	80	40	81	66.68	11.0	8.0
43	83	40	84	69.85	11.0	8.0
45	83	40	84	69.85	11.0	8.0
48	89	43	97	79.38	14.3	9.5
50	89	43	97	79.38	14.3	9.5
53	103	53	100	82.55	14.3	9.5
55	107	53	103	85.73	14.3	9.5
58	110	53	106	88.90	14.3	9.5
60	110	53	106	88.90	14.3	9.5
63	113	53	110	92.08	14.3	9.5
65	116	53	113	95.25	14.3	9.5
68	118	53	116	98.43	14.3	9.5
70	118	53	116	98.43	14.3	9.5
75	126	53	121	103.19	14.3	9.5
80	150	73	132	114.30	14.3	9.5
85	156	73	138	120.65	14.3	9.5
90	163	73	144	127.00	14.3	9.5
95	163	73	144	127.00	14.3	9.5
100	169	73	151	133.35	14.3	9.5

Dimensions in inches

Shaft (")	Rotary part		Stationary part				
	mm	d ₃	l ₃	d ₆	d ₇	l ₄	l ₅
0,875	22,23	57	31	51	40,6	8	4,8
1,000	25,40	61	33	54	42,9	8	4,8
1,125	28,58	67	36	65	50,8	11	8
1,250	31,75	70	37	68	54	11	8
1,375	34,93	73	38	71	57,2	11	8
1,500	38,10	76	38	78	63,5	11	8
1,625	41,28	80	40	84	69,9	11	8
1,750	44,45	83	40	84	69,9	11	8
1,875	47,63	86	43	97	79,4	14,3	9,5
2,000	50,80	89	43	97	79,4	14,3	9,5
2,125	53,98	103	53	103	95,7	14,3	9,5
2,250	57,15	107	53	106	88,9	14,3	9,5
2,375	60,33	110	53	106	88,9	14,3	9,5
2,500	63,50	113	53	110	92,1	14,3	9,5
2,625	66,68	116	53	116	98,4	14,3	9,5
2,750	69,85	118	53	116	98,4	14,3	9,5
2,875	73,03	122	53	121	103,2	14,3	9,5
3,000	76,20	126	53	121	103,2	14,3	9,5
3,250	82,55	150	73	138	120,7	14,3	9,5
3,500	88,90	156	73	144	127	14,3	9,5
3,750	95,25	163	73	144	127	14,3	9,5
4,000	101,60	169	73	151	133,4	14,3	9,5

Dimensions subject to changes or modifications.

PNL



COMPONENTS:

- 1 Rotating contact surface
- 2 Stationary contact surface
- 3 Bellows
- 3a Elastomeric cup
- 4 Spring
- 5 Ring
- 5a Drive ring
- 5b Metal frame

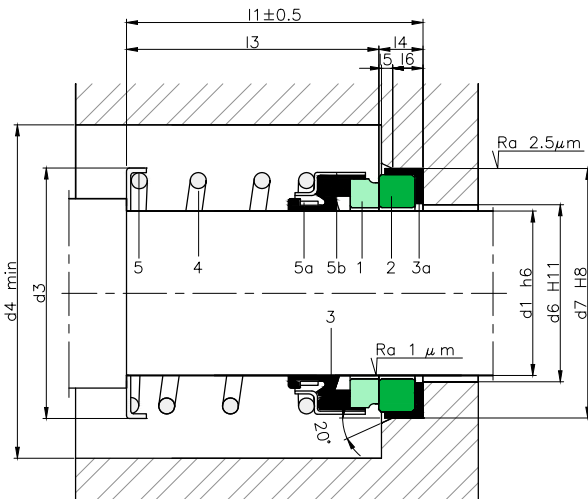

SECTORS:



CHARACTERISTICS:

- Unbalanced.
- Not dependent on the rotation direction.
- Single cylindrical spring.

OPERATING LIMITS:

$d_i = 8 \div 40 \text{ mm}$ $p = 12 \text{ kg/cm}^2$

$v = 10 \text{ m/s}$ $t = -20 \div +120^\circ\text{C} (*)$

(*) The temperature resistance depends on the material of the secondary seals used.

The operating limits are defined by the PV factor which is determined for the sealing system characteristics and those of the application.

DESCRIPTION:

Mechanical seal with a simple design for general use.

DIMENSIONS CHART

Dimensions in mm

Shaft mm	Rotary part			Stationary part					Total length l_1
	d_3	d_4	l_3	d_6	d_7	l_4	l_5	l_6	
8	22	27	15.5	14	26.00	5.5	0.5	4.5	21.0
10	22	27	15.5	14	26.00	5.5	0.5	4.5	21.0
11	22	27	15.5	14	26.00	5.5	0.5	4.5	21.0
12	22	27	15.5	14	26.00	5.5	0.5	4.5	21.0
13 A	28	33	18.0	17	29.50	8.0	1.0	6.0	26.0
13 B	32	37	13.0	17	29.50	8.0	1.0	6.0	21.0
14 B	28	33	18.0	17	29.50	8.0	1.0	6.0	26.0
14 C	28	33	22.0	19	23.10	6.0	1.2	3.0	28.0
14 A	32	37	13.0	17	29.50	8.0	1.0	6.0	21.0
15 A	28	33	18.0	17	29.50	8.0	1.0	6.0	26.0
15 B	32	37	13.0	17	29.50	8.0	1.0	6.0	21.0
16 C	28	33	18.0	17	29.50	8.0	1.0	6.0	26.0
16 F	28	33	23.0	21	26.90	7.0	1.5	4.0	30.0
16 E	31	36	29.0	17	29.50	8.0	1.0	6.0	37.0
16 A	32	37	13.0	17	29.50	8.0	1.0	6.0	21.0
16 D	32	37	13.0	17	42.00	8.0	1.0	6.0	21.0
16 B	33	38	16.3	17	29.50	8.0	1.0	6.0	24.0
18 A	32	37	24.0	20	42.00	8.0	1.0	6.0	32.0
18 B	32	37	24.0	25	30.90	8.0	1.5	4.0	32.0
19.05	32	37	19.0	22	35.00	10.2	1.2	7.8	24.0
19.05	32	37	22.0	22	35.00	10.2	1.2	7.8	32.2
20 A	32	37	22.0	22	42.00	8.0	1.0	6.0	30.0
20 B	44	49	14.0	22	42.00	8.0	1.0	6.0	22.0
22 A	39	44	25.0	30	35.40	8.0	2.0	4.0	33.0
22	44	49	14.0	23	42.00	8.0	1.0	6.0	22.0
25.4	42	47	27.2	29	41.25	11.0	1.5	8.5	38.2
30 B	52	57	28.0	33	52.00	12.0	1.5	8.5	40.0
30A	60	65	22.0	33	52.00	12.0	1.5	8.5	34.0
31.75	52	57	49.2	34	47.62	11.0	1.5	8.5	60.2
40	63	68	35.0	45	68.00	12.0	1.5	8.5	47.0

Dimensions subject to changes or modifications.

LCY

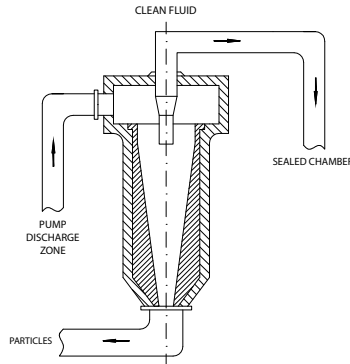

SECTORS:



CHARACTERISTICS:

- Working pressure: 64 bar.
- Temperature: up to 125° C
- Materials: Stainless steel.

DESCRIPTION:

Working fluids often contain sand particles, incrustated residue from boilers and pipes etc. which can damage the mechanical seal and reduce its durability. Situations of this type can be avoided by installing a cyclone.

This type of element is installed outside the pump, between the discharge zone and the mechanical seal chamber. A current or vortex of pressurised fluid is generated inside it and the effect of the centrifugal force separates the particles suspended in the fluid. The particles that are heavier than the fluid are thrown towards the walls and dragged to the lower part of the LC, while the clean fluid emerges from the top and is returned to the chamber where the mechanical seal is located.

API31 and API41 configuration.

These elements require no maintenance and do not become blocked over time.

LHP



SECTORS:



CHARACTERISTICS:

- Temperature: - 30° C to +110° C.
- Working pressure: 30 bar.
- Volume (L) : 2 l.
- Flow rate: 15 ml / run-out
- Materials: Stainless steel / polyethylene.

DESCRIPTION:

LHP with a built-in tank for placing on the reservoir. Installed directly in the LTS reservoir.

LQT

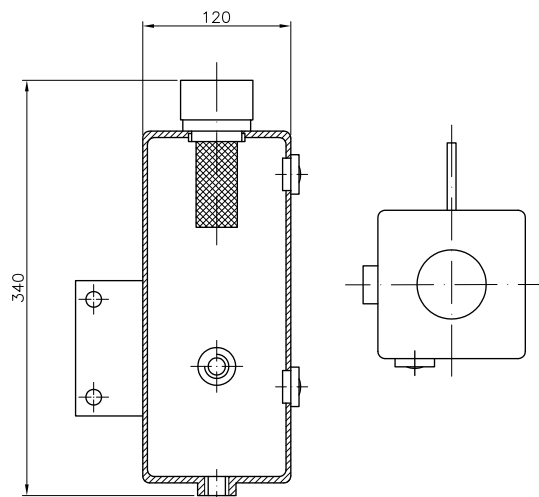

SECTORS:



CHARACTERISTICS:

- Temperature: -60° C to +200° C.
- Working pressure: up to 25 bar.
- Volume: 4, 6, 10 l.
- Materials: Stainless steel.

DESCRIPTION:

LST for supplying barrier fluid with or without pressure in double cartridge or mechanical seal installations which enables the circulation of the barrier fluid due to the thermosyphon effect or the pumping ring (mechanical seal). API52, API53 and API53A configuration.

LS



SECTORS:



CHARACTERISTICS:

- Ring with two allen screws for attaching it to the shaft.

DESCRIPTION:

This element is attached to the shaft to permanently ensure the compression of the rotating part of the mechanical seal. It can be used with rubber bellows or single spring mechanical seals.

DIMENSIONS CHART

Dimensions in mm

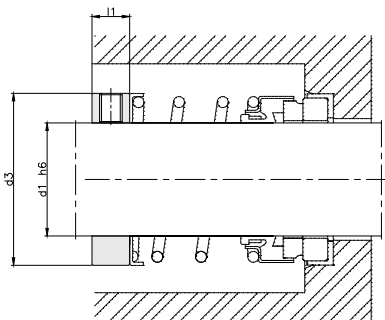

Shaft mm	d ₃	l ₁
12.0	21.0	7.5
12.7	21.0	7.5
14.0	23.0	7.5
15.0	24.0	7.5
15.8	25.0	7.5
16.0	25.0	7.5
18.0	31.0	7.5
19.1	31.0	7.5
20.0	33.0	7.5
22.0	35.0	7.5
22.2	35.0	7.5
24.0	37.0	7.5
25.0	38.0	7.5
25.4	38.0	7.5
28.0	41.0	7.5
28.6	41.0	7.5
30.0	43.0	7.5
31.7	45.0	7.5
32.0	45.0	10.0
33.0	46.0	10.0
35.0	48.0	10.0
38.0	53.0	10.0
40.0	55.0	10.0

Shaft mm	d ₃	l ₁
41.2	55.0	10.0
43.0	58.0	10.0
44.4	60.0	10.0
45.0	60.0	10.0
47.6	63.0	10.0
48.0	63.0	10.0
50.0	65.0	10.0
50.8	65.0	10.0
53.0	68.0	10.0
53.9	68.0	10.0
55.0	70.0	10.0
57.1	70.0	10.0
60.0	79.0	10.0
60.3	79.0	10.0
63.5	82.0	10.0
65.0	84.0	12.0
66.6	84.0	12.0
69.8	89.0	12.0
70.0	89.0	12.0
73.0	95.0	12.0
75.0	98.0	12.0
76.2	98.0	12.0

Dimensions subject to changes or modifications.

LST8

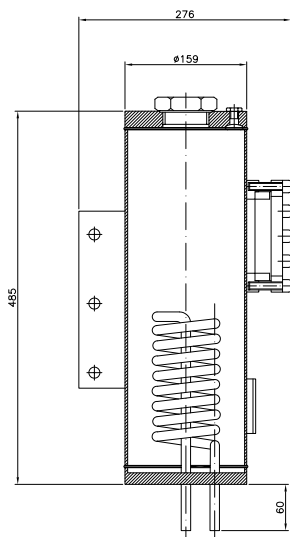

SECTORES:



CARACTÉRISTIQUES :

- Temperature: -60° C to +200° C.
- Working pressure: up to 16 bar.
- Volume: 8 l.
- Materials: AISI304.

DESCRIPTION :

LST8 for supplying barrier fluid with or without pressure in double cartridge or mechanical seal. It includes a cooling coil to regulate the temperature of the barrier fluid. Installations which enables the circulation of the barrier fluid due to the thermosyphon effect or the pumping ring (mechanical seal). API52, API53 and API53A configuration. It may be supplied with instruments for automatic level, pressure and temperature control.

LST9

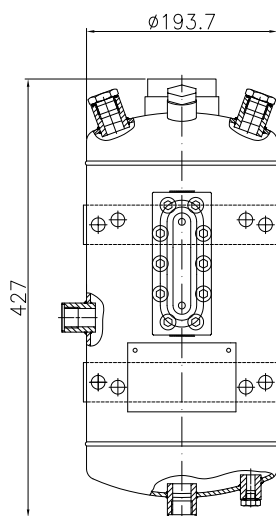

SECTORES:



CARACTÉRISTIQUES :

- Temperature: -60° C to +200° C.
- Working pressure: up to 25 bar.
- Volume: 9 l.
- Materials: Stainless steel.

DESCRIPTION :

LST9 for supplying barrier fluid with or without pressure in double cartridge or mechanical seal. It includes a cooling coil to regulate the temperature of the barrier fluid. Installations which enables the circulation of the barrier fluid due to the thermosyphon effect or the pumping ring (mechanical seal). API52, API53 and API53A configuration. It may be supplied with instruments for automatic level, pressure and temperature control.

With O-Ring

With anti-rotation pin and housing dimensions EN 12756

							L16	L1DIN	L9
d ₁	d ₆	d ₇	d ₈	l ₅	l ₆	l ₈	l ₄		
10	17	21	3	1,5	4	8,5	-	-	10
12	19	23	3	1,5	4	8,5	-	-	10
14	21	25	3	1,5	4	8,5	-	-	10
16	23	27	3	1,5	4	8,5	-	-	10
18	27	33	3	2	5	9	7	-	11,5
20	29	35	3	2	5	9	7	10	11,5
22	31	37	3	2	5	9	7	10	11,5
24	33	39	3	2	5	9	7	10	11,5
25	34	40	3	2	5	9	7	10	11,5
28	37	43	3	2	5	9	7	10	11,5
30	39	45	3	2	5	9	7	10	11,5
32	42	48	3	2	5	9	7	10	11,5
33	42	48	3	2	5	9	7	10	11,5
35	44	50	3	2	5	9	7	10	11,5
38	49	56	4	2	6	9	7	11	14
40	51	58	4	2	6	9	8	11	14
43	54	61	4	2	6	9	8	11	14
45	56	63	4	2	6	9	8	11	14
48	59	66	4	2	6	9	8	11	14
50	62	70	4	2,5	6	9	9,5	13	15
53	65	73	4	2,5	6	9	9,5	13	15
55	67	75	4	2,5	6	9	9,5	13	15
58	70	78	4	2,5	6	9	10,5	13	15
60	72	80	4	2,5	6	9	10,5	13	15
65	77	85	4	2,5	6	9	10,5	13	15
68	81	90	4	2,5	7	9	11	15	18
70	83	92	4	2,5	7	9	11,5	15	18
75	88	97	4	2,5	7	9	11,5	15	18
80	95	105	4	3	7	9	11,5	15,5	18,2
85	100	110	4	3	7	9	11,5	15,5	18,2
90	105	115	4	3	7	9	13	15,5	18,2
95	110	120	4	3	7	9	13	15,5	17,2
100	115	125	4	3	7	9	13	15,5	17,2

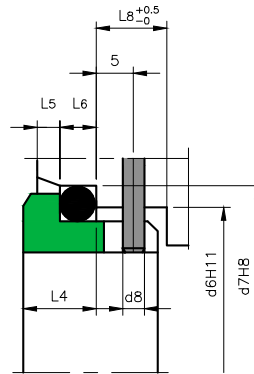

PF. L1 DIN
PF. L9
PF. L16

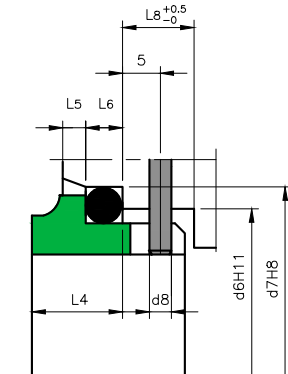

PF. L9 (*)

Without anti-rotation pin and housing dimensions EN 12756

			L606/ L6	LDIN		
d ₁	d ₆	d ₇	l ₄	l ₅	l ₆	
10	17	21	6,6	7	1,5	4
12	19	23	6,6	7	1,5	4
14	21	25	6,6	7	1,5	4
16	23	27	6,6	7	1,5	4
18	27	33	7,5	10	2	5
20	29	35	7,5	10	2	5
22	31	37	7,5	10	2	5
24	33	39	7,5	10	2	5
25	34	40	7,5	10	2	5
28	37	43	7,5	10	2	5
30	39	45	7,5	10	2	5
32	42	48	7,5	10	2	5
33	42	48	7,5	10	2	5
35	44	50	7,5	10	2	5
38	49	56	9	13	2	6
40	51	58	9	13	2	6
43	54	61	9	13	2	6
45	56	63	9	13	2	6
48	59	66	9	13	2	6
50	62	70	9,5	14	2,5	6
53	65	73	11	14	2,5	6
55	67	75	11	14	2,5	6
58	70	78	11	14	2,5	6
60	72	80	11	14	2,5	6
65	77	85	11	14	2,5	6
68	81	90	11,3	16	2,5	7
70	83	92	11,3	16	2,5	7
75	88	97	11,3	16	2,5	7
80	95	105	12	18	3	7
85	100	110	14	18	3	7
90	105	115	14	18	3	7
95	110	120	14	18	3	7
100	115	125	14	18	3	7

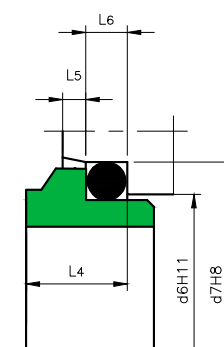

PF. L DIN (*)
PF. L606

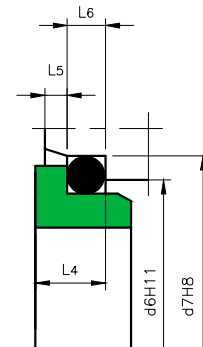

PF. L DIN
PF. L6

*(Only supplied in carbon).

With O-Ring

Without Anti-Rotation Pin

	L4/L7/L13	L	L4/L7/L13	L	L7	L	L4/L7	L13			L7
d ₁	d ₆		d ₇		d ₁₃		l ₄	l ₅	l ₆	l ₃₀	
10	15,5	14	19,2	18,1	17	5,5	6,6	-	1,5	4	2
12	17,5	16,5	21,6	20,6	19	5,5	5,6	-	1,5	4	1
14	20,5	19	24,6	23,1	21,5	6	5,6	-	1,5	4	1
16	22	21	28	26,9	24	7	7,5	-	1,5	4	1,5
18	24	25	30	30,9	27,5	7	8	10	2	5	2
20	29,5	25	35	30,9	32	8	7,5	9,5	2	5	1,5
22	29,5	30	35	35,4	32	8	7,5	9,5	2	5	1,5
24	32	30	38	35,4	35	8	7,5	9,5	2	5	1,5
25	32	33	38	38,2	35	8,5	7,5	9,5	2	5	1,5
28	36	38	42	43,3	38	9	9	11	2	5	3
30	39,2	38	45	43,3	42	9	10,5	11	2	5	3,5
32	42,2	38	48	43,3	45	9	10,5	11	2	5	4,5
33	44,2	45	50	53,5	46	11,5	11	11,5	2	5	5
35	46,2	45	52	53,5	48	11,5	11	11,5	2	5	5
38	49,2	52	55	60,5	52	11,5	10,3	11,5	2	6	4,3
40	52,2	52	58	60,5	55	11,5	10,8	11,5	2	6	4,8
43	53,3	57	62	60,5	59	11,5	12	14,3	2	6	2,5
45	55,3	57	64	65,5	59	11,5	11,6	14,3	2	6	2,2
48	59,7	57	68,4	65,5	65	11,5	11,6	14,3	2	6	2,2
50	60,8	64	69,3	72,5	64	11,5	11,6	14,3	2,5	6	2,2
53	63,8	-	72,3	-	69	-	12,3	14,3	2,5	6	2,5
55	66,5	64	75,4	72,5	71	11,5	13,3	15,3	2,5	6	2,5
58	69,5	-	78,4	-	75,5	-	13,3	15,3	2,5	6	3,5
60	71,5	72	80,4	79,3	75	11,5	13,3	15,3	2,5	6	2,5
65	76,5	77	85,4	84,5	81,5	11,5	13	15,3	2,5	6	3,2
68	82,7	-	91,5	-	87	-	13,7	16	2,5	7	3,7
70	83	82	92	89,5	87	11,5	13	15,3	2,5	7	3,7
75	90,2	87	99	94,5	91	11,5	14	15,3	2,5	7	3,2
80	95,2	92	104	99,5	100	11,5	15	16,3	3	7	4,7
85	100,2	98	109	105,5	102	13,5	14,8	16,3	3	7	4,5
90	105,2	105	114	111,5	110	13,5	14,8	16,3	3	7	3
95	111,6	110	120,3	116,5	116	13,5	15,8	17,3	3	7	4
100	114,5	114	123,3	119,5	119	13,5	15,8	17,3	3	7	4

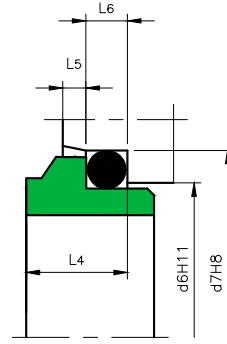

PF. L13
P.F.L (*)

*(Only supplied in carbon).

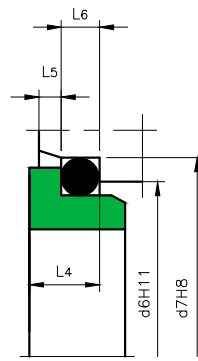

PF. L4
P.F.L

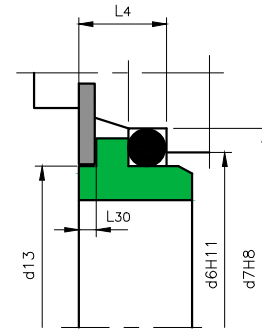

PF. L7 (*)

*(Locking ring not included)

With cup

	R / L60 / CDIN		L50				R	L60	CDIN	L50
d ₁	d ₆	d ₇	d ₆	d ₇	l ₅	l ₆	l ₄			
10	17	21	11,0	24,6	1,5	4	5	6,6	8,6	9
12	19	23	13,5	27,8	1,5	4	6	6,6	8,6	9
14	21	25	17,0	30,95	1,5	4	6	6,6	8,6	10,5
16	23	27	17,0	30,95	1,5	4	6	6,6	8,6	10,5
18	27	33	20,0	34,15	2	5	6	7,5	10	10,5
20	29	35	21,5	35,7	2	5	6	7,5	10	10,5
22	31	37	23,0	37,3	2	5	6	7,5	10	10,5
24	33	39	26,5	40,5	2	5	6	7,5	10	10,5
25	34	40	26,5	40,5	2	5	6	7,5	10	10,5
28	37	43	29,5	47,65	2	5	6	7,5	10	12
30	39	45	32,5	50,8	2	5	7	7,5	10	12
32	42	48	32,5	50,8	2	5	7	7,5	10	12
33	42	48	36,5	54	2	5	7	7,5	10	12
35	44	50	36,5	54	2	5	8	7,5	10	12
38	49	56	39,5	57,15	2	6	8	9	11	12
40	51	58	42,5	60,35	2	6	8	9	11	12
43	54	61	46,0	63,5	2	6	8	9	11	12
45	56	63	46,0	63,5	2	6	8	9	11	12
48	59	66	49,0	66,7	2	6	10	9	11	12
50	62	70	52,0	69,85	2,5	6	10	9,5	13	13,5
53	65	73	55,5	73,05	2,5	6	10	11	13	13,5
55	67	75	58,5	76,2	2,5	6	10	11	13	13,5
58	70	78	61,5	79,4	2,5	6	10	11	13	13,5
60	72	80	61,5	79,4	2,5	6	12	11	13	13,5
65	77	85	68,0	92,1	2,5	6	12	11	13	16
68	81	90	71,0	95,25	2,5	7	12	11,3	15,3	16
70	83	92	71,0	95,25	2,5	7	12	11,3	15,3	16
75	88	97	77,5	101,6	2,5	7	12	11,3	15,3	16
80	95	105	84,0	114,3	3	7	12,5	12	15,7	20
85	100	110	87,0	117,5	3	7	12,5	14	15,7	20
90	105	115	93,5	123,85	3	7	12,5	14	15,7	20
95	110	120	96,5	127	3	7	12,5	14	15,7	20
100	115	125	103,0	133,35	3	7	12,5	14	15,7	20

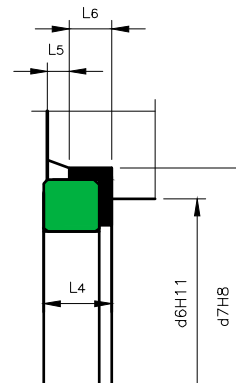

PF. R
PF. C DIN
PF. L50
PF. L60

In inches

d_1		L12	L12/L22/A/C11		L12 / L22 / A	L12/L22/A/C11		A / C11 / L22	L12
(")	mm	d_6 mm	d_7 inch	mm	d_8 mm	l_5 mm	l_6 mm	l_4 mm	mm
0,250	6,350	14,45	0,75	19,05	3	-	-	-	5,92
0,375	9,525	17,63	0,88	22,23	3	1,5	4,9	7,92	5,92
0,500	12,700	20,80	1,00	25,40	3	1,5	4,9	7,92	5,92
0,625	15,875	27,15	1,25	31,75	3	1,5	7,3	10,31	6,62
0,750	19,050	30,33	1,38	34,93	3	2	6,8	10,31	6,62
0,875	22,225	33,50	1,50	38,10	3	2	6,8	10,31	6,62
1,000	25,400	36,68	1,63	41,28	3	2	7,6	11,10	6,62
1,125	28,575	39,85	1,75	44,45	3	2	7,6	11,10	6,62
1,250	31,750	43,03	1,88	47,63	3	2	7,6	11,10	6,62
1,375	34,925	46,20	2,00	50,80	3	2	7,6	11,10	6,62
1,500	38,100	47,98	2,13	53,98	4	2	7,6	11,10	7,53
1,625	41,275	54,33	2,38	60,33	4	2	9,1	12,70	8,2
1,750	44,450	57,50	2,50	63,50	4	2	9,1	12,70	8,2
1,875	47,625	60,68	2,63	66,68	4	2	9,1	12,70	8,2
2,000	50,800	63,85	2,75	69,85	4	2,5	8,6	12,70	8,2
2,125	53,975	70,20	3,00	76,20	4	2,5	10,2	14,27	9,53
2,250	57,150	73,38	3,13	79,38	4	2,5	10,2	14,27	9,53
2,375	60,325	76,55	3,25	82,55	4	2,5	10,2	14,27	9,53
2,500	63,500	79,73	3,38	85,73	4	2,5	10,2	14,27	9,53
2,625	66,675	79,73	3,38	85,73	4	2,5	11,8	15,88	9,53
2,750	69,850	82,90	3,50	88,90	4	2,5	11,8	15,88	9,53
2,875	73,025	85,65	3,75	95,25	4	2,5	11,8	15,88	11,33
3,000	76,200	88,83	3,88	98,43	4	3	11,3	15,88	11,33
3,125	79,375	92,00	4,00	101,60	4	3	13,7	19,84	14,33
3,250	82,550	95,18	4,13	104,78	4	3	13,7	19,84	14,33
3,375	85,725	98,35	4,25	107,95	4	3	13,7	19,84	14,33
3,500	88,900	101,53	4,38	111,13	4	3	13,7	19,84	14,33
3,625	92,075	104,70	4,50	114,30	4	3	13,7	19,84	14,33
3,750	95,250	107,88	4,63	117,48	4	3	13,7	19,84	14,33
3,875	98,425	111,05	4,75	120,65	4	3	13,7	19,84	14,33
4,000	101,600	114,23	4,88	123,83	4	3	13,7	19,84	14,33

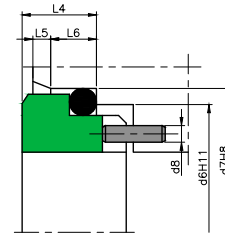

PF. L12

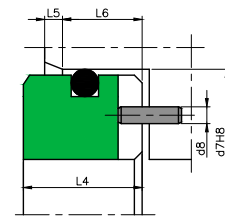

PF. A

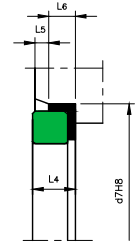

PF. C11

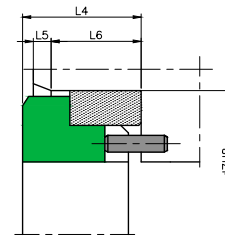

PF. L22

d_1	d_7	d_{10}	l_9	l_{10}	
(")	mm	mm	mm	mm	
0,750	19,050	36,51	48,00	4,8	8
0,875	22,225	39,69	51,00	4,8	8
1,000	25,400	42,86	54,00	4,8	8
1,125	28,575	50,80	65,00	8	11
1,250	31,750	53,98	68,00	8	11
1,375	34,925	57,15	71,00	8	11
1,500	38,100	63,50	78,00	8	11
1,625	41,275	66,68	81,00	8	11
1,750	44,450	69,85	84,00	8	11
1,875	47,625	73,03	87,00	8	11
2,000	50,800	79,38	97,00	9,5	14,3
2,125	53,975	82,55	100,00	9,5	14,3
2,250	57,150	85,73	103,00	9,5	14,3
2,375	60,325	88,90	106,00	9,5	14,3
2,500	63,500	92,08	110,00	9,5	14,3
2,625	66,675	95,25	113,00	9,5	14,3
2,750	69,850	98,43	116,00	9,5	14,3
2,875	73,025	100,01	117,00	9,5	14,3
3,000	76,200	103,19	121,00	9,5	14,3
3,125	79,375	-	-	-	14,3
3,250	82,550	114,30	132,00	9,5	14,3
3,375	85,725	-	-	-	14,3
3,500	88,900	120,65	138,00	9,5	14,3
3,625	92,075	-	-	-	14,3
3,750	95,250	127,00	144,00	9,5	14,3
3,875	98,425	-	-	-	14,3
4,000	101,600	133,35	151,00	9,5	14,3

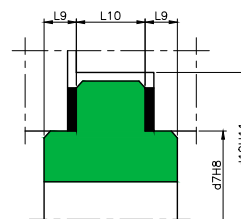

PF. T

Special designs

It is not always possible to use a conventional mechanical seal. Complex applications with special requirements and pumps with small housings need mechanical seals with non-standard profiles.

Our engineering centre designs and manufactures customised solutions adapted to the specific needs of our customers, in large or small production runs.

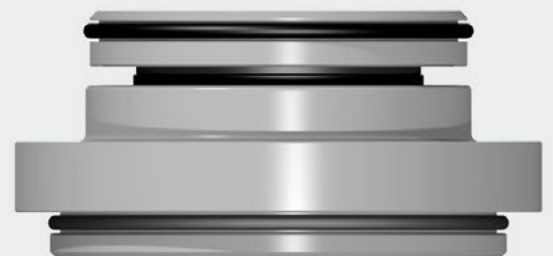
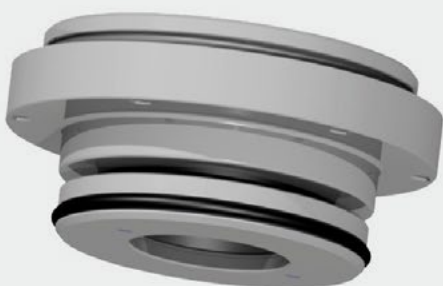
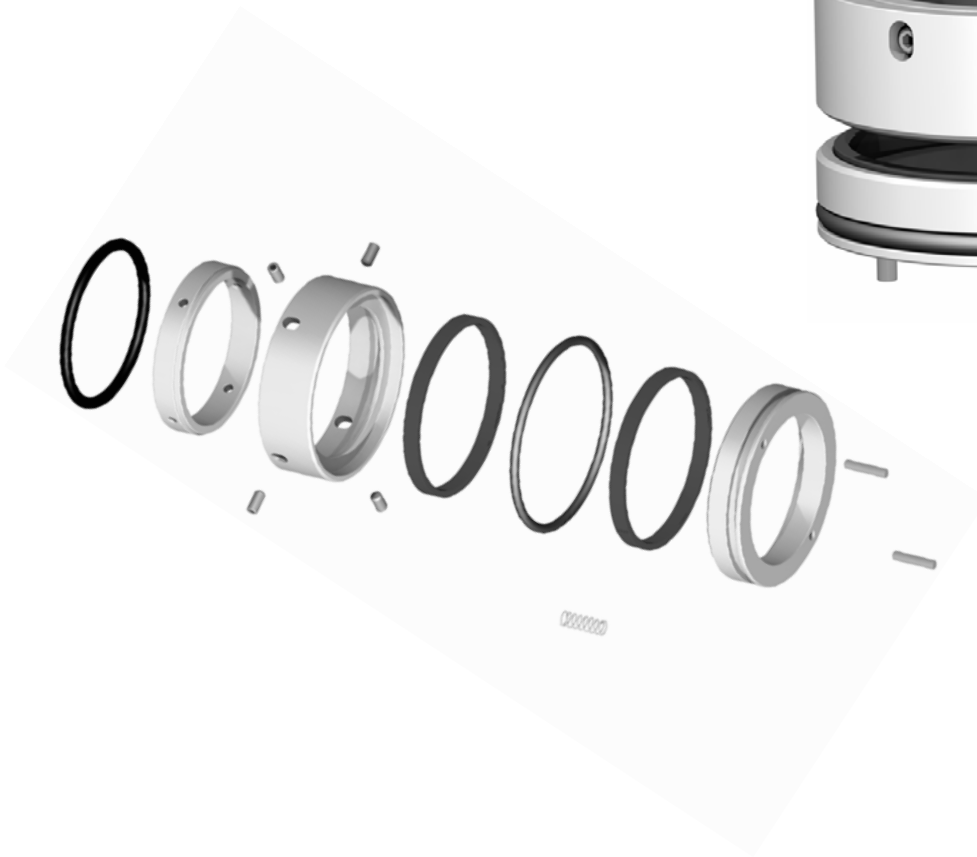







RMS seals

The RMS seal range is compatible with the most popular pump brands: Flygt®, Grundfos-Sarlin®, ABS®, Alfal Laval®, Hilge®, APV®, Fristam®, etc. These mechanical seals have special designs for wastewater pumps, heating, food products, pharmaceuticals and many applications in all kinds of industrial sectors. In most cases, when a pump is repaired, the mechanical seal is not the only element that is replaced. The renewal of other parts is also recommended, such as O-rings or joints with special profiles, bearings, pins, flat gaskets, etc. We offer kits containing these elements which are supplied along with the mechanical seal.

TYPE

ABS®

	LRB17, AB-107-25, AB-107-90	SECTORS 
	AB30-25, AB30-48, AB30-65, AB30-80, AB30-90, AB30-100	SECTORS 
	AB-SH-32, AB-SH-40, AB-SH-50, AB-SH-45, AB-SH-55, AB-SH-60, AB-SH-65, AB-SH-70	SECTORS 



TYPE

Afec®

	AF-BV-16 AF-FS-20 AF-FS-25	SECTORS 
-------------------------------------------------------------------------------------	----------------------------------	------------------------------------------------------------------------------------------------

TYPE

Allweiller®

	AW-SP-15, AW-SP-20	SECTORS 
	LS18	SECTORS 

TYPE

Amstrong®

	AM- VG-28.58 AM- VG-41.28	SECTORS 
-------------------------------------------------------------------------------------	------------------------------	------------------------------------------------------------------------------------------------





TYPE

Alfa Laval®









	AL-A-22	SECTORS 		AL-ALS-45	SECTORS 
	AL-C-40, AL-C-53 AL-C-60	SECTORS 		AL-CQ-32	SECTORS 
	AL-D-22, AL-D-41.28 AL-D-317	SECTORS 		AL - E - 22	SECTORS 
	AL-E-32	SECTORS 		AL- EMR-27 AL - E-27	SECTORS 
	AL-F-55 AL-F-75	SECTORS 		AL-GN-25 AL-GN-30	SECTORS 
	AL-HCL-20, AL-HCL-25, AL-HCL-30, AL-HCL-35, AL-HCL-40	SECTORS 		AL - I - 22	SECTORS 
	AL-IB-30 AL-IB-50.8	SECTORS 		AL-LK-32 AL-LK-40	SECTORS 
	AL-N-22	SECTORS 		AL-S-20, AL-S-30 AL-S-35, AL-S-45 AL-S-55, AL-S-75	SECTORS 
	AL-SD-20, AL-SD-30	SECTORS 		AL-SRU-30 AL-SRU-45 AL-SRU-55	SECTORS 

RMS SEALS

TYPE Alfa Laval®

 <p>AL-TC-19.05 AL-TC- 28.6 AL-TC- 38.1</p> <p>SECTORS</p> 	 <p>AL-SX-45, AL-SX-70</p> <p>SECTORS</p> 
---------------------------------------------------------------------------------------------------------------------------------------------------------------------------------------------------------------------------------------	--------------------------------------------------------------------------------------------------------------------------------------------------------------------------------------------------------------







TYPE Alfa Laval®

Contherm®	
 <p>AL-CQ-50.8</p> <p>SECTORS</p> 	 <p>AL-PF-38.1</p> <p>SECTORS</p> 
 <p>AL-PR-38.1, AL-ML-38.1</p> <p>SECTORS</p> 	 <p>AL-PR-50.8, AL-ML-50.8</p> <p>SECTORS</p> 

TYPE APV®

 <p>AP-W-25 AP-W-35</p> <p>SECTORS</p> 	 <p>AP-HCH-60</p> <p>SECTORS</p> 
 <p>AP-SIM-25</p> <p>SECTORS</p> 	 <p>AP-WP-25 AP-WP-35</p> <p>SECTORS</p> 
 <p>AP-R-20, AP-R-25 AP-R-30</p> <p>SECTORS</p> 	 <p>AP-S-35</p> <p>SECTORS</p> 
 <p>AP-WD-40 AP-WD-55 AP-WD-80</p> <p>SECTORS</p> 	 <p>AP-WF-25 AP-WF-35</p> <p>SECTORS</p> 





TYPE Calpeda®

 <p>AR / LRB31</p> <p>SECTORS</p> 	 <p>CP-SH-15</p> <p>SECTORS</p> 
 <p>CP-155-1820 FN / 155</p> <p>SECTORS</p> 	

TYPE Apec®

	<p>SC-V-12, SC-V-16, SC-V-22</p> <p>SECTORS</p> 
-------------------------------------------------------------------------------------	-----------------------------------------------------------------------------------------------------------------------------------------

TYPE APV®

	<p>AP-H-28.60, AP-H-47.60 AP-H-53.90</p> <p>SECTORS</p> 
	<p>AP-P-25.4 AP-P-38.1</p> <p>SECTORS</p> 

TYPE Bornemann®

	<p>BR-A-2840 BR-A-4055</p> <p>SECTORS</p> 
	<p>BR-B-2840 BR-D-2840</p> <p>SECTORS</p> 

TYPE CN-Pumps®





	<p>CN-A-12 CN-A-16</p> <p>SECTORS</p> 
---------------------------------------------------------------------------------------	---------------------------------------------------------------------------------------------------------------------------------

TYPE Ebara®

















	<p>EB-12-S</p> <p>SECTORS</p> 
	<p>EB-15-D, EB-3035, EB-40-D, EB-45-D, EB-4045, EB-4550</p> <p>SECTORS</p> 

RMS SEALS

TYPE EMU®

	<p>EM-D-35, EM-D-50 EM-D-75</p> <p>SECTORS</p> 
	<p>EM-S-35, EM-S-50 EM-S-75</p> <p>SECTORS</p> 

TYPE Flygt®

	<p>SECTORS</p> 		<p>SECTORS</p> 
	<p>SECTORS</p> 		<p>SECTORS</p> 
	<p>SECTORS</p> 		<p>SECTORS</p> 
	<p>SECTORS</p> 		<p>SECTORS</p> 

TYPE Frick®

	<p>FK-MSPF-50.8</p> <p>SECTORS</p> 
-----------------------------------------------------------------------------------	-----------------------------------------------------------------------------------------------------------------------

TYPE Fristam®

	<p>FR-30</p> <p>SECTORS</p> 		<p>FR-35</p> <p>SECTORS</p> 
	<p>FR-CQ-1</p> <p>SECTORS</p> 		<p>FR-CQ-2</p> <p>SECTORS</p> 
	<p>FR-CQ-3</p> <p>SECTORS</p> 		<p>FR-CQ-4</p> <p>SECTORS</p> 
	<p>FR-CQ-5</p> <p>SECTORS</p> 		<p>FR-CQ-6</p> <p>SECTORS</p> 
	<p>FR-CQ-7</p> <p>SECTORS</p> 		<p>FR-D-45</p> <p>SECTORS</p> 
	<p>FR-EN-22</p> <p>SECTORS</p> 		<p>FR-EN-22BS FR-EN-30BS</p> <p>SECTORS</p> 
	<p>FR-EN-30, FR-EN-35</p> <p>SECTORS</p> 		<p>FR-ENC-22</p> <p>SECTORS</p> 
	<p>FR-FM-43</p> <p>SECTORS</p> 		<p>FR-ENS-22</p> <p>SECTORS</p> 
	<p>FR-FP-736 35</p> <p>SECTORS</p> 		<p>FR-FT-22, FR-FT-30</p> <p>SECTORS</p> 
	<p>FR-G-22</p> <p>SECTORS</p> 		<p>FR-GL-30-35</p> <p>SECTORS</p> 
	<p>FR-GL-50</p> <p>SECTORS</p> 		<p>FR-GL-1301</p> <p>SECTORS</p> 

RMS SEALS



TYPE Fristam®

	FR-LG-22 SECTORS 		FR-LG-30 SECTORS 
	FR-LG-35 SECTORS 		FR-PD-22 FR-PD-30 SECTORS 
	FR-PFD-22 SECTORS 		FR-PFL-22 SECTORS 
	FR-S-60 SECTORS 		FR-SH-30 SECTORS 
	FR-SH-22 SECTORS 		FR-SH-35 SECTORS 
	FR-W-38 SECTORS 		FR-ZB-18, FR-ZB-22 FR-ZB-30 SECTORS 
	FR-Z-12, FR-Z-18 FR-Z-21 FR-Z-28 SECTORS 		

TYPE Grundfos-Sarlin®

	GR-AC-12 GR-AC-16 SECTORS 		GR-A-LG-22 SECTORS 		GR-B-12, GR-B-16 SECTORS 
	GR-B-SH-12 GR-B-SH-16 SECTORS 		GR-B-15, GR-B-22 GR-B-28, GR-B-33 GR-B-38, GR-B-45 GR-B-48, GR-B-65 SECTORS 		GR-B-32 SECTORS 
	GR-C-12-A SECTORS 		GR-C-12-12 SECTORS 		CQ-GR-13, CQ-GR-16 CQ-GR-15 SECTORS 
	GR-H-12, GR-H-16 GR-H-22 SECTORS 		GR-SA-16, GR-SA-25, GR-SA-35 SECTORS 		GR-SA-38-SPRING SECTORS 
	GR-SA-30-SUP, GR-SA-38-SUP GR-SA-50-SUP, GR-SA-65-SUP SECTORS 		GR-SA-65 SECTORS 		GR-SA-4355 SECTORS 

TYPE Gorman - Rupp®

	GRN-31'7, GRN-38'1 GRN-47.6 SECTORS 
-------------------------------------------------------------------------------------	------------------------------------------------------------------------------------------------------------------------------------------------

TYPE Grasso®

	GS-MB-60 SECTORS 
	GS-MS-65 SECTORS 
	GS-WS-18 SECTORS 

TYPE Grundfos-Sarlin®

	GR-A-12, GR-A-16 GR-A-22 SECTORS 
---------------------------------------------------------------------------------------	-----------------------------------------------------------------------------------------------------------------------------------------------

RMS SEALS

TYPE

Grundfos-Sarlin®



GR-SA-LG-65

SECTORS

**GR-SA-32-INF, GR-SA-38-INF
GR-SA-50-INF, GR-SA-65-INF**

SECTORS





GR-SE-22, GR-SE-32

SECTORS



TYPE

Herborner®



**HB-A-24, HB-A-28
HB-A-38**

SECTORS



TYPE

Hidrostal®



**HI-15'80, HI-28'60
HI-38'10, HI-50'80**

SECTORS

**HI-107-28'60, HI-107-38'10
HI-107-50'80, HI-107-63'50
HI-107-76'20**

SECTORS



TYPE

Hilge®



**HG-19-S, HG-28-S
HG-38-S**

SECTORS



HG-28

SECTORS





HG-28-SP

SECTORS



TYPE

Hisaka®



**HSK-20
HSK-35
HSK-45**

SECTORS



TYPE

Howden®



HD-MB-C-50

SECTORS



**HD-MS-A-44.95
HD-MS-A-53.97
HD-MS-A-66.7**

SECTORS



TYPE

Imo®



IM-G-22

SECTORS



HD-MS-B-44.45

SECTORS





HD-MS-D-66.67

SECTORS



TYPE

Inbeat®



**IB-15, IB-20
IB-25, IB-35**

SECTORS



TYPE

Jabsco®



JA-LH-25'4-C

SECTORS



TYPE

Johnson®



**JH-AC-24, JH-AC-40
JH-AC-60**

SECTORS



**JH-LP-35, JH-LP-50
JH-LP-70**

SECTORS









RMS SEALS

TYPE Johnson®

	272-IN-28, 272-IN-35 272-IN-50 SECTORS 
	JH-TW-30, JH-TW-48 JH-TW-63 SECTORS 





TYPE Lowara®

	LW-B-16, LW-B-22 LW-B-25 SECTORS 
	LW-FH-12, LW-FH-16, LW-FH-22, LW-FH-25 SECTORS 
	LW-155-14, LW-155-22 LW-155-28, LW-155-33 SECTORS 





TYPE Pumpex®

	PX-SUP-PC-25 SECTORS 
-------------------------------------------------------------------------------------	----------------------------------------------------------------------------------------------------------------

TYPE Marelli®

	AR/LRB31 SECTORS 
	LRB17KU-L60 SECTORS 

TYPE KSB®

	KS-D-40 SECTORS 
	KS-LSC-65 SECTORS 

TYPE Nikuni Pumps®

	NK-A-15, NK-A-17 NK-A-20, NK AOR-17 SECTORS 
	NK-B-30 NK-B-55 SECTORS 

TYPE Nochi®

	KR-12 KR-16 SECTORS 
-------------------------------------------------------------------------------------	------------------------------------------------------------------------------------------------------------------



TYPE Mouvex®

	MX-A-22, MX-A-30 MX-A-35, MX-A-45 MX-BA-35, MX-BA-45, MX-B-35, MX-B-45 SECTORS 
	MX-C-35, MX-CA-55 MX-CA-35, MX-CA-40 SECTORS 

TYPE Pedrollo®

	PD-VX-20 SECTORS 
-------------------------------------------------------------------------------------	------------------------------------------------------------------------------------------------------------

TYPE Pumpex®

	PX-KP-40 SECTORS 
	PX-INF-25 SECTORS 

TYPE Mycon®

	MY-MSA-55 MY-MSB-55 SECTORS 
	MY-MSB-55 SECTORS 

RMS SEALS

TYPE Mycon®



MY-MS-28
MY-MS-40

SECTORS



MY-WS-22

SECTORS



TYPE Salmson®



SM-AC-14, SM-AC-18,
SM-AC-22, SM-AC-28,
SM-AC-38

SECTORS



TYPE Sabroe®



SB-MB-35, SB-MB-44.45
SB-MB-60

SECTORS



SB-MZ-75

SECTORS



TYPE Sedical®



SD-A-12, SD-A-18
SD-A-20, SD-A-25
SD-A-32

SECTORS



TYPE Someflu®



SF-ESP-1

SECTORS



SF-HMPS-22

SECTORS



SF-HMPN-22

SECTORS



SF-SP-160

SECTORS



TYPE Suntec®



SNT-A-25

SECTORS



TYPE Tuchenhagen®



TN-HG-25, TN-HG-30
TN-HG-32, TN-HG-35
TN-HG-60

SECTORS



TYPE Tsurumi®



TS-H2530, TS-H3035
TS-H3540, TS-H4550

SECTORS



VI 100-31,75

SECTORS



TS-W-14-HL, TS-W-14-VL
TS-H20T, TS-H30T, TS-H45,
TS-H60, TS-H25, TS-H35,
TS-HT40

SECTORS



VI 101-36,5

SECTORS



TYPE Waukesha®



WK-T-30, WK-T-40
WK-T-50, WK-T-60

SECTORS



WK-TC-40
WK-TC-60
WK-TC-50

SECTORS



TYPE Wilo®



W-MS-30

SECTORS



LRB17

SECTORS



TYPE Witt®



WT-28
WT-28L

SECTORS



Production center

Lidering's modern, adequate equipment enables it to execute repair and transformation operations on mechanical seals and cartridges.

The process commences by diagnosing the condition of the part, and after this, we execute the necessary processes for cleaning, polishing and lapping the contact surfaces, grinding parts and replacing components, etc.

After carrying out these operations, the sealing of the repaired parts is checked by pressure test, to ensure that the part is ready for operation in any application that requires sealing of the highest standard.



We also offer additional services such as a diagnostic report on the sample received and a detailed analysis of the faults observed or laser marking of parts to facilitate their identification and traceability.

Quality control, checking and testing

All the mechanical seals manufactured or repaired by Lidering are subject to the strictest quality controls. We guarantee their operation in the most demanding applications.

Furthermore, if the customer wishes, we can provide other services such as sealing controls in static or dynamic conditions and at different pressures before delivering the product. Working along this line we perform static sealing controls on all our cartridges before delivering them to the customer.

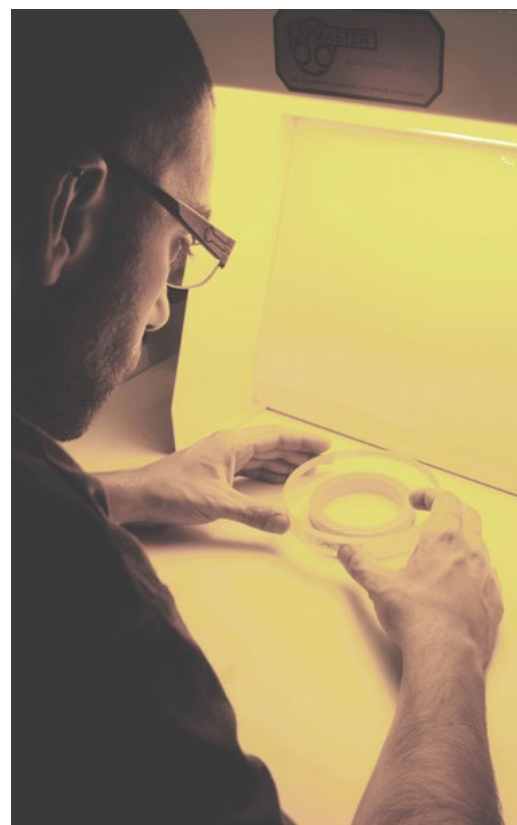

Certificates:

The standards that regulate industrial sectors are becoming more and more stringent. Our mechanical seals may be supplied with the following certificates:



Mechanical seals suitable for use in equipment installed in explosive atmospheres in categories 2 and 3 of group II (2 G / D) cT2 in accordance with Directive 2014/34 / EU (ATEX) of the European Parliament and of the Council of 26 February 2014 on the harmonization of the laws of the Member States relating to equipment and protective systems for use in potentially explosive atmospheres.



The Productive Centre in Reus (Tarragona) has been Saqr-ATEX certified. This certification allows us to carry out repairs on non electrical equipment with ATEX certification of any type and category: mechanical seals, cartridges, pumps, agitators, etc.; Area 0, 1, 2, 20, 21, 22, etc.; while maintaining the same level of ATEX certification.



The FDA (Food & Drug Administration) is a US-based organisation whose mission is to safeguard health and safety in food and medicines. The CFR 21 (Code of Federal Regulations) is a series of standards and rules that must be met by materials that enter into are intended to be in contact with food and medicines. This code of regulations includes different parts, depending on the type of material in question. For instance, part 177 refers to polymers and in particular, section 2600 refers to elastomers (FDA CFR 21 §177.2600).



European Regulation (EC) 1935/2004:

One of the objectives of this regulation is to establish a basis for guaranteeing a high standard of protection for human health and the interests of consumers with respect to materials and objects that come into direct or indirect contact with food. It is enforced in the European Union. It also establishes that those materials and objects must be manufactured in accordance with a best practice code.

Regulation EC 2023/2006 is a best practice code for manufacturing objects and materials that come into direct or indirect contact with food.

Regulation EU 10/2011 is a specific measure included in Regulation EC 1935/2004 which applies to polymers that are designed to come into contact with food. It also establishes that they must comply with a series of special additional provisions governing composition, as well as being compliant with the provisions of Regulations EC 1935/2004 and EC 2023/2006.

We can provide materials for mechanical seals that are compliant with Regulation EC 1935/2004 and with Code EC 2023/2006 and Regulation EU 10/2011 in the case of elastomers for secondary seals.

General information

Introduction

Mechanical seals are elements that ensure the sealing between a rotating shaft and a structural part (usually fixed) of the application assembly. This sealing effect is achieved through the rotating movement between two contact surfaces which are extremely flat and the fluid film generated between them, which prevents the passage of the rest of the fluid.

Mechanical seals perform much better than other sealing elements for rotating shafts such as lip seals or retaining elements. Since they are made of harder materials, they make the system more solid and durable. They also allow sealing in applications which are especially demanding: chemically aggressive, abrasive, dense or viscous fluids, high temperatures, high pressures, high rotating speeds, etc.

Mechanical seal elements

1. Primary ring:

This part of the mechanical seal contains the contact surface. It has a spring-operated device which makes it flexible enough to offset small axial or radial displacements or oscillations that may occur during operation. This generally refers to the rotating part of the mechanical seal.

2. Mating ring:

In most cases, this part of the mechanical seal is housed in a rigid casing or static flange of the application but it may also be mounted on the shaft. It contains the contact surface. In addition to generating the air tightness with the contact surface of the primary ring, it serves as a guide for ensuring perpendicularity.

3. Secondary seals:

These elements generate air tightness between the static parts of the mechanical seal, for instance, between the primary ring and the shaft, the mating ring and the flange or between the different parts of the primary ring that rotate together. For this purpose, elastomers are normally used, with O-rings being the most common element. Bellows seals, square cut seals, collars, wedge seals and in general, any seal that provides air static or linear tightness can also be used. In addition to elastomers, special materials such as PTFE and seals with a graphite base can be used in heavy-duty working conditions.

4. Springs:

This element is responsible for maintaining the tension between the contact surfaces when there is no pressure in the system, to ensure sealing in static and depressurised conditions. Different types of spring can be used. The most common ones are: axial cylindrical springs, axial conical springs, multi-spring systems, welded wave springs, “super sinus” wave springs and metal bellows seals.

Other metal parts:

It is common to find mechanical seals with construction elements for joining and fixing the above parts. These are usually metal parts or plates, rings, screws, etc.

5. Drive mechanism:

This transmits the rotating movement of the shaft to the rotating part of the mechanical seal. This mechanism may consist of flaps, an anti-rotating pin, screws elastomer bellows, etc.

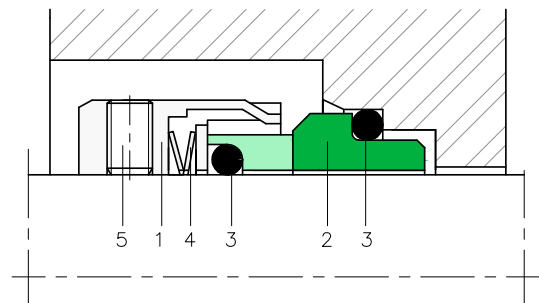

Mechanical seal classification

Different criteria exist for classifying mechanical seals. They are usually classified based on their hydraulic balance, construction and assembly characteristics.

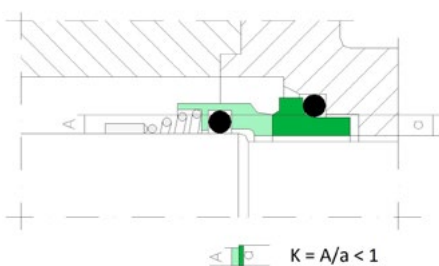

• K Hydraulic balance:

Mechanical seals can be classified based on the ratio between the pressure of the fluid to be sealed and the contact pressure between the contact surfaces, i.e., the ratio between the surface with the hydraulic pressure (A) and the contact surface (a).

GENERAL INFORMATION

A non-balanced mechanical seal has the following ratio: $K = A/a > 1$ and a balanced mechanical seal has a ratio of $K = A/a < 1$.

In designing mechanical seals, K values of between 0.6 and 1.2 are used. A value under 0.6 favours the duration and life of the mechanical seal, but will not guarantee adequate sealing.

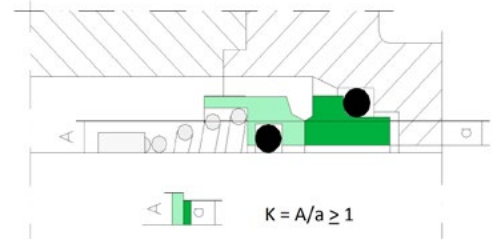

Construction

This classification is related to the characteristics and design of the different components that are used to make the mechanical seal. Each variation responds to special application needs or characteristics.

• Conical spring seal:

These seals are defined by the type of spring they use, and their function. They have an axial conical-shaped spring with one end fixed to the primary ring and the opposite end to the shaft. The spring maintains the tension between the contact surfaces and transmits the shaft movement to the rotating part of the mechanical seal. Conical spring seals are usually mechanical seals with a dependent

rotation direction, i.e., they can only function properly in the direction of the rotation for which they are designed. They are normally supplied with the rotation direction to the right, and the left rotation option is only supplied if specifically ordered.

Secondary seals are usually O-rings, since they require no bellows to transmit the movement.

• Bellows seals:

These mechanical seals have a secondary bellow seal on the shaft. There are bellows of different types made of different materials, and each one gives a different, specific performance:

- **Elastomer bellows seals:** The bellows are made of elastomer material and are responsible for generating static sealing on the shaft, and also for transmitting the shaft movement to the mechanical seal. The spring mechanism that is normally used is an axial cylindrical spring, which means that the performance of these mechanical seals does not depend on the shaft rotation direction.

- **Metal bellows seals:** The spring mechanism in these seals are metal bellows. Their main advantage is in how they perform: they are more resistant to abrasion and chemicals (particularly in combination with chrome-nickel alloys) than elastomer bellows, and have a higher temperature resistance (when secondary seals made of graphite are mounted), and prevent particles or traces of fluid from becoming trapped in the spring coils (the folds of the bellows act like a pumping element) and they permit the use of a “static O-ring” as a secondary seal.

In other seals the O-ring or the bellows are in the primary ring of the seal, generating static sealing. However, their behaviour in real

operating conditions is not strictly static and there may be: movement due to wear of the contact surfaces, vibrations or oscillations which lead to the axial shifting of the shaft or other factors that have a dynamic effect on the O-ring. In the worst case, if combined with a poor surface finish of the shaft, this causes wear or damage in the O-rings. However, the “static O-ring” system permitted by this type of seal is through the bellow, which absorbs the displacements. The O-ring is at the opposite end of the bellows with respect to the primary ring and not at all affected by these defects.

There are two different types of metal bellows seals, depending on the bellows construction characteristics.

-**Welded bellows seals:** They are formed by ring plates welded together along their perimeter at the ends, which is the most common type.

-**Rolled bellows seals:** They are more complex in construction terms and is formed by an undulated metal tube. It has a larger elastic run and is often used in applications that involve demanding sterilisation processes, as there are no corners or closed angles where undesirable particles could accumulate, which makes them easy to clean.

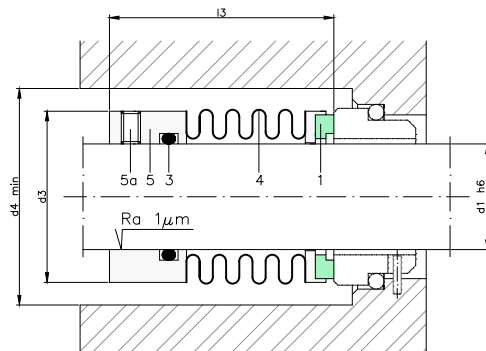
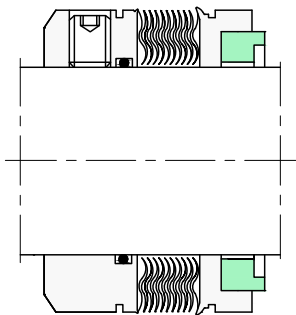

- PTFE bellows seals:

PTFE is a plastic with high chemical resistance to practically all working fluids and a temperature resistance that is higher than most elastomers. These features make them extremely useful in certain applications. PTFE bellows are used for the same purpose as metal bellows. They have a more limited resistance to temperature and abrasion but higher chemical resistance. With respect to the secondary seals, it has a bushing or wedge that is also made of PTFE, which operates on a static basis. This is a very special type of seal that is used for working fluids that are extremely aggressive in chemical terms.

- **Multispring seals:**

These have a spring mechanism formed by small springs distributed diametrically inside the mechanical seal. The function of these springs is to homogeneously generate tension between the contact surfaces. In addition they absorb vibrations or errors in alignment that arise while the seal is being mounted and during its operation. They are normally used in stirring devices or in pumping applications with clean fluids.



- **Wave spring seal:**

Wave springs have a higher elasticity constant than other springs, and require less space to generate the necessary working pressure. In this seal design, the length of the seal assembly is an important parameter and greater attention to this should be paid than in other cases. As well as permitting mechanical seals with smaller assembly measurements, wave spring seals are not as affected by dirt (fibres, particles) or by the high density or viscosity of the fluid. For this reason they are very useful in waste or sewage water applications and when used with dense, thick, sticky fluids.

Two different types of wave spring seals are normally used: the welded wave spring type and the “super sinus” type. The welded wave spring type consists of two folded metal rings welded together which create a spring-like effect when they are forced by compression. The “super sinus” type is a rolled, undulated metal tape that generates a spring-like effect when compressed due to the elasticity of the metal.

- **Cartridge seals:**

Unlike conventional mechanical seals, cartridge seals have a compact presentation. The components are mounted on a metal sleeve inside a flange. They are very easy to install. All that must be done is to slide and fasten the sleeve to the shaft and secure the flange to the application casing, which ensures ease in assembly.

In some cases the cartridges require more complex assemblies than one the described above, for instance when they must be installed in flush, recirculation, barrier fluid or quench systems with one or two mechanical seals, as will be described later on. A distinction should be made between single and double cartridges depending on whether they have one or two sets of contact surfaces inside them. In addition the cartridges may contain different spring systems such as axial cylindrical, multispring, wave spring and metal bellows systems, with the multispring system being the most common one.

Assembly characteristics

The mechanical seal assembly type (internal or external, single or double) is determined by the application, the working conditions and different factors related to the environment.

- **Single assemblies:**

- **Internal single assembly:**

This is the most common type. The fluid is in contact with all the mechanical seal components; the chemical compatibility of these with the fluid must be ensured. It is best to use it when working with clean fluids or loaded ones with a concentration that does not endanger the lubricating characteristics of the fluid.

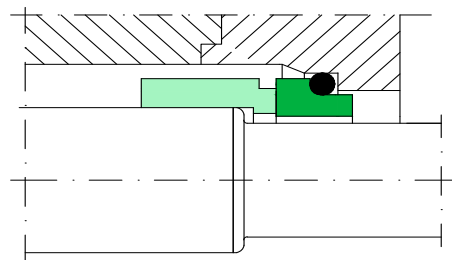
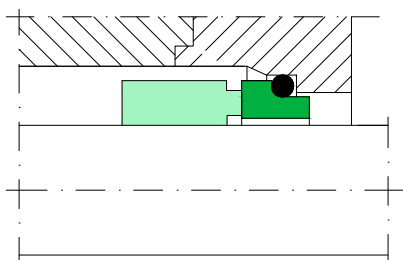

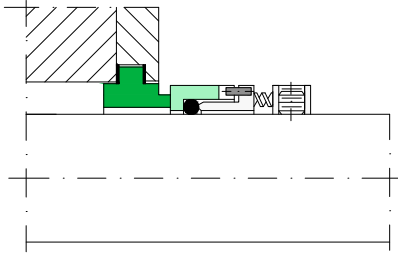

- Single external assembly:

This is used when the fluid contains fibres or solids which could block the spring, when the medium to be sealed is chemically very aggressive and may attack the metals used to make the springs, or in certain hygienic applications that require exhaustive cleaning or sterilising processes (usually within the scope of food and pharmaceutical processing industries).

• Double assemblies:

In some cases a single assembly is not sufficient to ensure sealing or the desired performance of an application. Some examples of these special applications are:

- Applications with costly, dangerous or contaminant fluids.
- Applications where it is essential to immediately detect a failure in the sealing system.

- Applications with non-lubricating fluids.
- Applications with fluids at high temperatures where cooling is necessary.
- Applications that operate with fluids at very high pressures.

The main configurations of double assemblies are as follows:

- “Back-to-back” assemblies:

This type is recommended for sealing non-lubricating fluids, gases, fluids with a high concentration of solids or with a tendency to crystallise, adhesives, pastes, paints or dangerous fluids.

This assembly requires the injection of a fluid known as buffer or barrier fluids in the chamber formed by the two seals. The barrier fluid pressure must be 1.5 to 2 bar above the pressure of the fluid to be sealed. Therefore, if there is a leak on the product side, the leak will be towards the interior of the system and the barrier fluid will be mixed with the product fluid. This characteristic is especially interesting in cases in which the working fluid is dangerous or pollutant.

It is not advisable to use this installation with no pressure in the barrier fluid, as the product fluid pressure could open up a leak route through the secondary seal of the stationary part or between the contact surfaces.

One advantage of this type of assembly compared to the others is that it permits a very short assembly length, which usually incurs fewer costs.

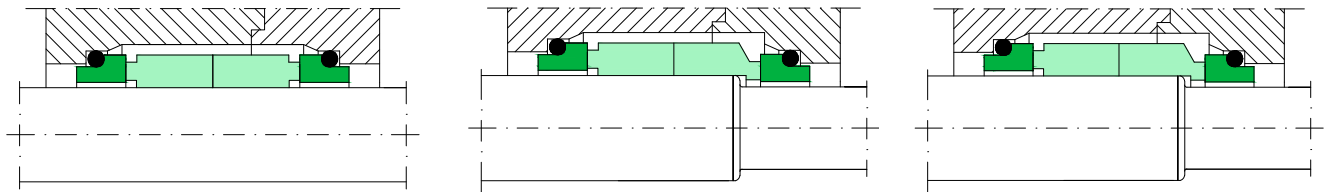

- “Face-to-face” assemblies:

This type is recommended for sealing non-lubricating fluids, gases, fluids with a high concentration of solids or with a tendency to crystallise, adhesives, pastes, paints or dangerous fluids.

This type of assembly makes it possible to work with pressurised barrier fluids or non-pressurised ones, depending on the application needs, which makes it a versatile, reliable assembly. It has improved tolerance to the pressure oscillations of the barrier fluids, and to axial shifting and vibrations in the system.

Given that it can work at excess pressure and low pressure, the leak can be directed in the most appropriate direction: towards the product or towards the barrier fluid. In all cases, the hydraulic balancing must be considered.

Since one rotating part of the mechanical seal has no components in the internal chamber of the sealing system, it is advisable to add a mechanism that will generate a pumping movement.

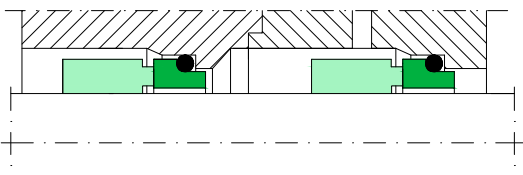
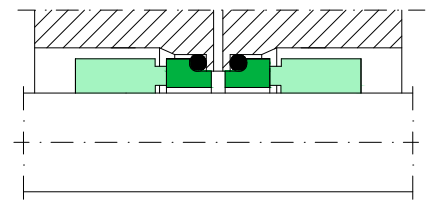

- “Tandem” assembly:

This is used to seal non-lubricating fluids, gases or dangerous fluids. In this case the fluid to be sealed is in contact with the seal components in contact with the product. The barrier fluids should be at a pressure of approximately 1 kg/cm² below the pressure of the fluid to be sealed, meaning that the direction of a leak would be towards the barrier fluid. This is particularly interesting for working fluids which must not contaminate the barrier fluid.

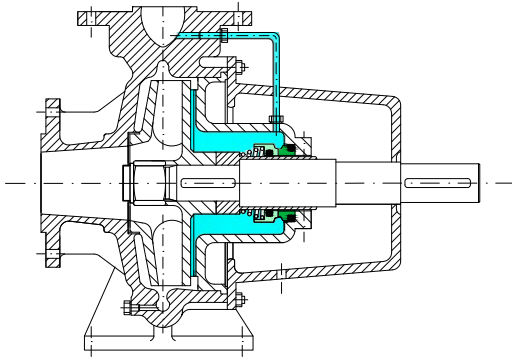

• **Auxiliary assemblies :**

- **Circulation:**

This system consists of circulating a small quantity of the fluid, aspirated or piped, to make it act on the contact surfaces. In this way the heat generated is eliminated and particles and sediments are removed from the mechanical seal closure. It is recommended to install a cyclonic filter.
Corresponds to Plan API 11.

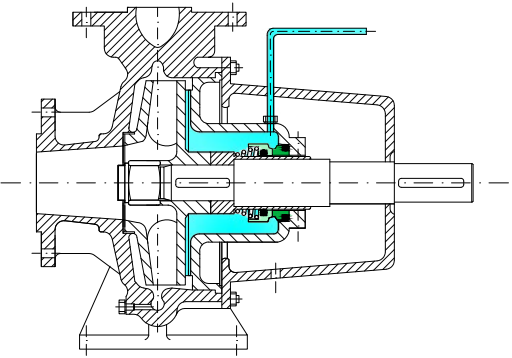

- **Flush:**

This consists of injecting an external fluid that is compatible with the mechanical seal closure. The pressure of this fluid must be approximately 2 bar above that of the fluid to be sealed. It is used in applications where the fluid is sticky, very thick or contains a high concentration of abrasive substances.
Corresponds to Plan API 32.

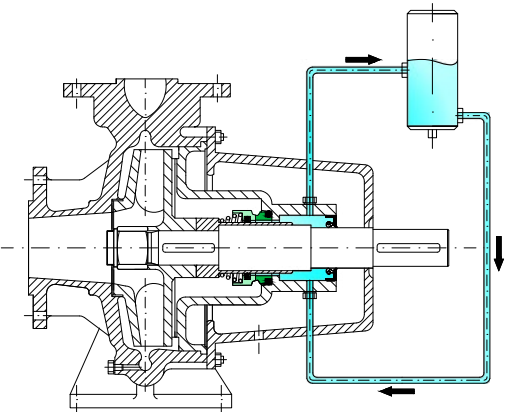

- **Quench or drain:**

In this system, a fluid is injected on the external side of the mechanical seal. Normally, an auxiliary sealing system must be provided. It is used in cases where there is a possibility that the fluid to be sealed will freeze, during short periods of dry operation and with gases or very dangerous fluids.
Corresponds to Plan API 62.

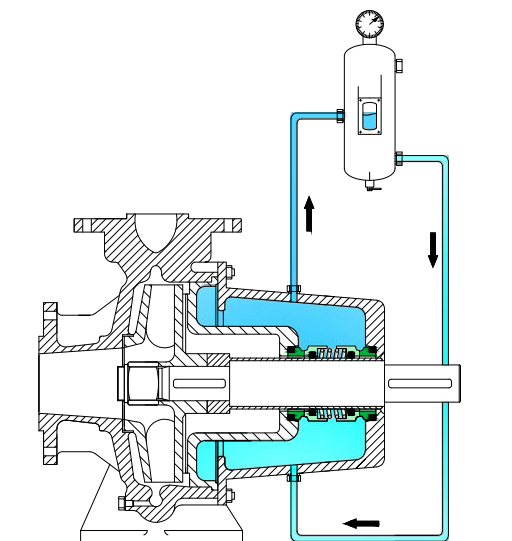

- **Pressurised barrier fluid:**

This system is used in double mechanical seal assemblies. A fluid is injected into the interior chamber between the two mechanical seals, at a specific pressure. This pressure may be above or below the working fluid pressure, depending on the application needs.

Excess pressure will be used if the working fluids must be directed towards the exterior in the event of a sealing failure. This way, the barrier fluid will enter the product side and be mixed with it. It is recommended in cases of toxic, dangerous or pollutant fluids or if the product is not harmed with mixed with the barrier fluid.

It must be used at a lower pressure than that of the working fluid if the aim is to prevent the working fluid from contaminating the barrier fluid, for instance, with very costly working fluids.

A lubricating fluid is normally used which can evacuate the heat generated between the contact surfaces. It is advisable for it to have a pressure 1 and 2 bar above (or below) the pressure of the working fluid.

The circulation of the barrier fluid takes place through a thermosyphon effect; elements which facilitate this circulation exist, such as a pumping ring on the mechanical seal casing. By placing the appropriate devices in the tank the level, pressure, temperature can be read, or the barrier fluid pressure can be generated.

Corresponds to Plan API 52, 53A.

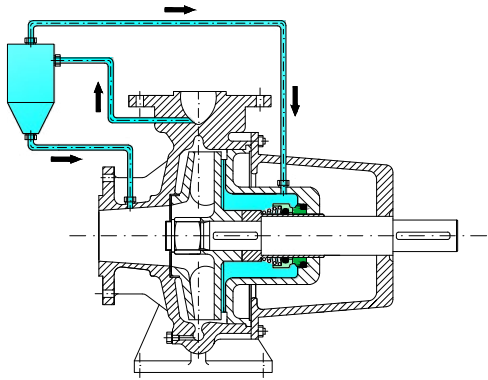

- Cyclonic filter:

A cyclonic filter is an auxiliary accessory used in the circulation assembly. The circulation fluid would pass through the cyclonic filter before reaching the sealing area. The cyclonic filter is a filtering system which separates the particles in suspension in the working fluid through a kinetic effect generated by the movement of the pumped fluid and by the geometry of the filter. This way, the fluid reaching the sealing area is free from particles in suspension, as these are expelled to the pump intake area.

Corresponds to Plan API 31.

Names and codes of the materials

The continuous development of European standards has also brought about the unification of mechanical seals with respect to their dimensions and the materials used to make them.

The mechanical seals manufactured by LIDERING are identified in accordance with the following chart.

Type	Balancing	Diameter	Normal length	Stationary part	Materials code								
					1	2	3	4	5	6	7	8	
LRB17		35	KU	L6	B	Q	E	F	F				
LMS20T	B	1-7/8"		L22	Q	Q	T	G	G				
LMS10D		60		L9	Q1	Q	V	G	G	B	Q	V	
LS60	B	20	DIN	LDIN	F1	B	P	G	F1				
LMB85		2"		A	B	Q	H	G2	G				
LDC38		65			A	Q1	K	M1	G	B	Q	V	

Ej: -LRB17KU-35-L50 (BQPF) → LRB17 type single mechanical seal, not balanced, for a shaft of 35 mm, length and housing measurements in accordance with EN 12756, with an L50-type stationary part.
 -LWS10B-90-L1 DIN (QQVGG) → LWS10B-type single mechanical seal, balanced, for a shaft of 90 mm, with an L1 DIN type stationary part and housing measurements in accordance with EN 12756
 - LMS10D-2 1/2" (UUKM1G2BQV) → LMS10D type double mechanical seal, not balanced, for a shaft of 2 1/2", with standard stationary parts in accordance with catalogue.

Type: See index.

Balancing: B if balanced, generally not indicated if not balanced (see K hydraulic balancing section).

Diameter: Shaft output diameter (in shafts with steps, this is the lower diameter). It may be in mm or in inches.

Normal length: Length L1 of mechanical seal in accordance with the indications of standard EN 12756. May be for short assemblies (KU), long ones (NU or DIN) or non-standard assemblies (not indicated).

Stationary part: See stationary parts section. The stationary parts indicated as DIN comply with the housing dimensions of standard EN 12756.

Materials:

- For single seals:

- 1- Friction face of the rotating part
- 2- Friction face of the stationary part
- 3- Secondary seals
- 4- Spring
- 5- Other metal parts

- For double seals:

- 1- Friction face of the rotating part on the product side
- 2- Friction face of the stationary part on the product side
- 3- Secondary seals on the product side and shaft
- 4- Spring
- 5- Other metal parts
- 6- Friction face of the rotating part on the atmospheric side
- 7- Friction face of the stationary part on the atmospheric side
- 8- Secondary seals on the atmospheric side

See materials codes in section "materials".

Additional technical specifications:

For special applications certain additional specifications are required, to define the necessary characteristics of the mechanical seal.

• **Rotation direction:** This only affects mechanical seals with a dependent rotation direction. They are normally supplied by default for working with "right" rotation directions. To indicate the "left" rotation direction, add L after the seal type.

P. Ej. LS18-40L-L4 (BQVGG)

• **Cartridge seals:** The nomenclature for mechanical cartridge seal references has some differences. The stationary parts and balancing are not specified, and neither are the standardisation of the dimensions or the rotation direction.

GENERAL INFORMATION

However the type of assembly is indicated:

S: Single assembly. One set of sealing faces, usually with a washing system.

D: Double assembly. Two sets of sealing faces with a barrier fluid system ready for pressurising. The layout of the faces may be “tandem”, “back-to-back” or “face-to-face” (see “Assemblies” section).

SQ: Single assembly with Quench (see “Assemblies” section).

• Installation

Mechanical seals are precision parts that need to be installed correctly and accurately. The assembly dimensions and tolerances indicated in the catalogue must be respected in full. It is very important to ensure they are not assembled in dirty or contaminated environments.

-Surface finish of the shaft and housing:

All the surfaces in contact with the mechanical seal must be free from burrs and sharp edges. It is essential to respect the Ra roughness indicated below:

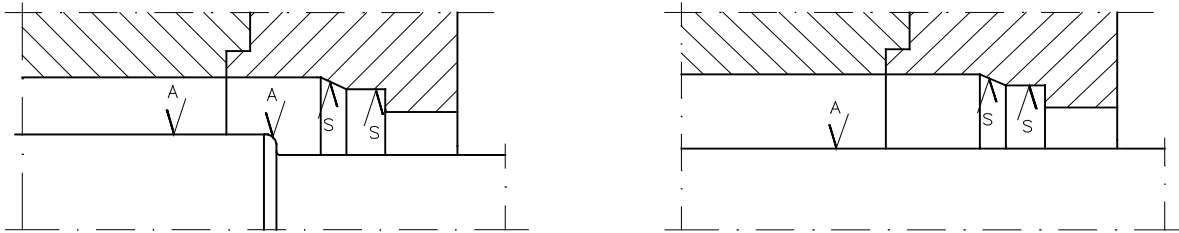

Secondary Closure	S	A
Elastomers	2,5 µm	1 µm
Non-elastomers	1,6 µm	0,2 µm

Shaft tolerances: h6

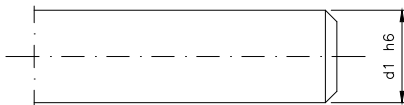

Eccentricity < 0,1 mm

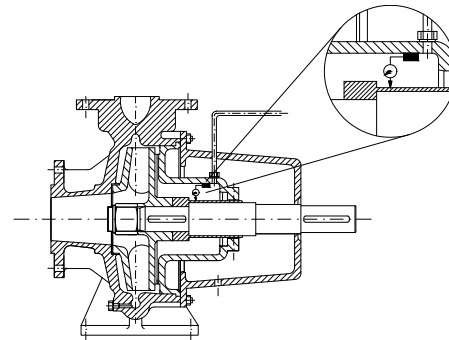

Axial movement: < 0,13 mm

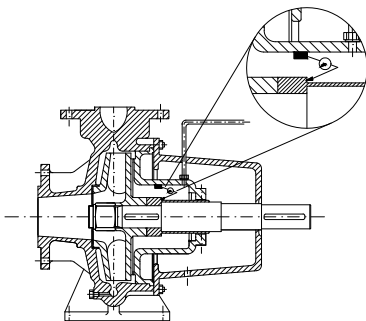

Perpendicularity: < 0,002 mm per mm Ø eje

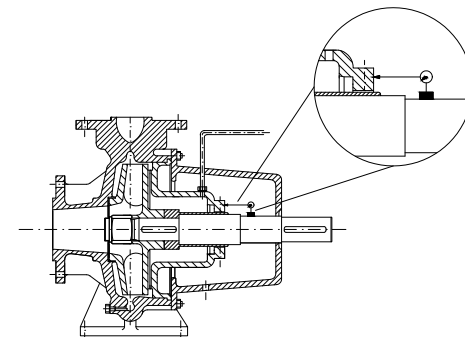

- Assembly method:

1. It is preferable to lubricate the areas. To do this, it is advisable to use an aqueous 2-3% neutral liquid soap solution. In all cases, do not use lubricants with a mineral base when manipulating seals made of EPDM material.

2. The stationary part must be facing the housing and be inserted perpendicularly, taking care not to damage the contact surface. It is very important to ensure that the contact surface is not knocked by any part of the housing and in particular, of the shaft. When using materials such as silicon carbide, this point is especially delicate as they are extremely fragile materials which could easily be damaged.

GENERAL INFORMATION

3. It is advisable to use assembly tools to ensure an even distance from the axial forces and thereby prevent incorrect positioning or bending stress which could damage the part.

In the case of cartridge mechanical seals:

4. Lubricate the shaft with an aqueous 2-3% neutral liquid soap solution. Also lubricate the screws and nuts of the pump.
5. Slide the cartridge along the shaft until the flange meets the casing. Check that the flat joint has not moved from its housing.
6. Tighten the flange screws
7. Tighten the drive screws on the shaft.
8. Remove the positioning staples setting clips and keep them for subsequent use.
9. Check the centring of the seal on the shaft. Move the shaft with your hand in order to detect a potential metal-on-metal noise. If you hear the noise, put the setting clips back in place and loosen the flange screws and the drive screws. Repeat the process from step 2. If the noise continues, check the centring of the shaft.
10. Couple the corresponding washing, circulation, barrier fluid and Quench connections. These connections are usually threaded, pursuant to the NPT standard. Their diameter is indicated in the cartridge files.
11. In a double cartridge, connect an external fluid to cool the secondary seal.

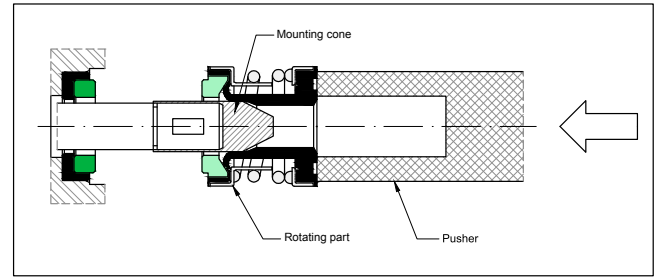

In all cases it is essential to make sure that the working fluid is in contact with the seal before starting up the application, as dry operation could seriously damage the sealing provided by the contact surfaces, even if operating for only short periods of time. Although it is true that in some applications, dry operation cannot be avoided, special combinations of materials can be recommended to reduce the negative impact of this situation.

Selecting the mechanical seals

The following information should be taken as a general reference and for preliminary guidance purposes in selecting the mechanical seals. For technical or economic reasons, other types of mechanical seals can be provided, made of different materials from those described here. For a selection that is more precise and in keeping with the special requirements of each application and each customer, please contact your LIDERING sales team.

The selection of the mechanical seal configuration, depending on the fluid and the working conditions, is set out in the "Sectors" section. When selecting the materials of the mechanical seal, the following criteria can be followed:

• Contact surfaces:

The materials used for the contact surfaces are classified as "hard" and "soft". The "hard" ones include steel, carbide, oxide and ceramic. "Soft" materials include carbon and PTFE.

As a general rule, combinations with one surface made of a hard material and the other of a soft material or both surfaces of a hard material are used.

- "Soft"- "hard" material combinations:

Whenever possible, it is best to use a combination of hard-soft materials as this has a series of advantages in comparison with a combination of hard materials. The most common are:

- **BV, BX** → **Economic combination:** normally used in applications involving running water. It is not suitable for dry operation, and in operations with little lubrication or with sudden changes in temperature. Ceramic has very low thermal conductivity and, since it undergoes enormous increases in temperature, it may cause fractures due to thermal shock.

- **BF, BG** → **"Soft" combination:** stainless steel, despite being considered "hard", may be marked and damaged by contaminant particles found in working fluids. The friction coefficient is not optimum but the material has an excellent capacity to conduct and evacuate the heat generated. In addition, the steel surface has great tenacity in the face of oscillation or knocks which could occur during assembly and while the application is in operation.

- **BQ, BU** → **"Hard" combination:** it has a good friction coefficient and is suitable for difficult working conditions.

- **AQ, AU** → **Combination for high temperatures:** antimony-impregnated carbon is suitable for working in conditions without solids in suspension of up to 350° C.

- **YV, Y1V** → **Combination for strong acids:** PTFE has great chemical resistance and ceramic is chemically resistant to most working fluids.

The benefits of a combination of soft-hard materials are:

- lower friction coefficient which means a smaller loss of power and less heat generation between surfaces. It should be considered that excessive heating is a major cause of damages and subsequently, leaks in mechanical seals.

- In most cases, a lower cost and greater availability of the material.

- They can be used in environments with little lubrication or fluids with low lubrication. They are better able to withstand the conditions of hypothetical dry operation.

The only disadvantage is their wear, which is greater than a hard combination and the ensuing shortening of the useful life of the seal.

GENERAL INFORMATION

- “Hard”-“hard” material combinations:

When working with fluids containing particles in suspension, fluids which can chemically attack carbon impregnation or which require a durable assembly, it is best to use a combination of hard materials. The most common are:

- **QQ → Silicon-Silicon:** This is the hard combination most often used. It has greater chemical resistance and the best friction coefficient of all the hard combinations. However, it is also the most fragile material and has the greatest risk of being damaged during assembly. Different silicon carbide grades can be used to obtain special performances in the surfaces (Q_1 , Q_6).

- **UU → Tungsten-Tungsten:** This is the most resistant option in mechanically aggressive working conditions. It has good resistance to impact, to vibrations, and to a large variety of chemicals. It is usually more expensive than silicon. Its friction coefficient is greater and so it is advisable to ensure good lubrication. This combination is widely used in wastewater and fluids loaded with particles such as sand or silt.

Secondary seals

The material used for the secondary seals is selected based on two criteria: the working temperature and the potential chemical attack of the working fluid.

With respect to the working temperature, the following graph is given as a guide:

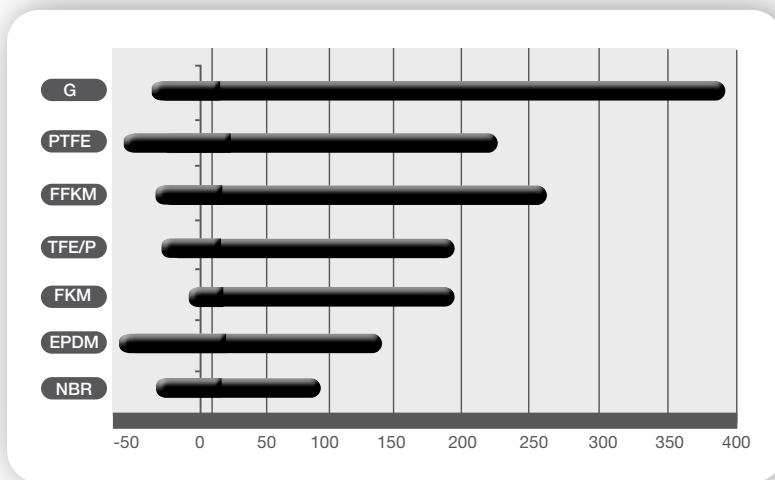

NBR is the most economical material and the one with the lowest useful working temperature range and graphite is the most suitable material for working at high temperatures. Within the elastomer group, FFKM is the material that is most resistant to temperature, allowing temperatures of 320° C to be reached in some special compounds, on demand.

With respect to chemical resistance, the following table is given as a guide pag 84.

Materials Codes (EN 12756)

Contact surfaces (position I and II)

SYNTHETIC CARBONS

A:	Antimony-impregnated carbon
B:	Resin-impregnated carbon
B ₂ :	Resin-impregnated carbon
B ₃ :	Pure non-impregnated carbon
B ₄ :	Self-lubricating carbon
B ₅ :	Hot pressed carbon

METALS

E:	Chromium steel; AISI 420 (1.4021 ; 1.4028)
F ₁ :	Nickel-chromium steel; AISI 431 (1.4057)
G:	Nickel-chromium-molybdenum steel; AISI 316 (1.4401)
D:	Duplex stainless steel (1.4462 ; 1.4162)
Z:	Nickel-chromium-molybdenum steel with chrome oxide
Z ₂ :	Nickel-chromium-molybdenum steatite steel
C:	Brass
C ₂ :	Bronze

CARBIDES

U:	Tungsten carbide with welded / inserted nickel
U ₁ :	Solid tungsten carbide with nickel
Q ₁ :	Sintered silicon carbide with no free silicon
Q ₂ :	Sintered silicon carbide
Q ₅ :	Sintered Silicon carbide with no free silicone diamond coating
Q ₆ :	Sintered silicon carbide with carbon

CERAMIC MATERIALS

V:	Alumina oxide 99,5%
V ₂ :	Alumina oxide 95%
X:	Steatite

SYNTHETIC MATERIALS

Y:	Glass-filled PTFE
Y ₁ :	PTFE-graphite

Synthetic carbons

Synthetic carbons are the materials most often used due to their intrinsic characteristics: they are self-lubricating, economical and have good chemical resistance. There are several types:

Code A: Antimony-impregnated carbon.

It has less chemical resistance than resin-impregnated carbon but is used due to its resistance to high temperatures (350°C). It is recommended for high pressure applications with hydrocarbons, thermal oils or gases.

Code B: Resin-impregnated carbon.

The most standard and economical. It can withstand temperatures of up to 180°C.

Code B₂: Resin-impregnated carbon.

A mechanised carbon with a more compact internal structure which gives it greater chemical resistance than type B graphite.

Code B₃: Non-impregnated carbon.

A carbon with no resin or metal content with a very high resistance to temperature (3000° C) and chemicals.

Secondary seals (position III)

ELASTOMERS

P:	Nitrile rubber (NBR)
H:	Hydrogenated nitrile (HNBR).
N:	Chloroprene rubber®(CR)
E:	Ethylene-propylene diene monomer (EPDM)
X:	Ethylene-propylene diene monomer peroxide (EPDMPX)
S:	Silicon rubber (MVQ)
V:	Fluorocarbon (FKM)
K:	Perfluorocarbon rubber (FFKM)
M:	Rubber coated with PTFE (FEP-FKM / FEP-MVQ)
A:	Tetrafluoro-ethylene Propylene Rubber (TFE/P or Aflas®)

NON-ELASTOMERS

G:	Graphite
T:	PTFE

Springs and other metal parts (position IV and V)

E:	Chromium steel; AISI 420 (1.4021; 1.4028)
F:	Nickel-chromium steel; AISI 304 (1.4301)
F ₁ :	Nickel-chromium steel; AISI 431 (1.4057)
G:	Nickel-chromium-molybdenum steel; AISI 316 (1.4401)
G ₂ :	AM350 nickel-chromium-molybdenum steel. AM350
G ₃ :	AISI 904L (1.4539)
G ₄ :	316Ti (1.4571)
L:	Nickel-chromium-molybdenum steel; AISI 316L (1.4404)
L ₂ :	Nickel-chromium-molybdenum steel; AISI 316L (1.4435)
D:	Nickel-chromium-molybdenum duplex stainless steel (1.4462)
D ₂ :	Super Duplex (1.4410)
M:	Hastelloy® C4
M ₂ :	Inconel® 718 (2.4668)
M ₃ :	Alloy® 20 (2.4668)
M ₄ :	Monel®400
M ₅ :	Hastelloy® C276 (2.4819)
B:	Brass
R:	AISI 316 + PTFE coverage

Ceramic materials

Ceramic materials have extremely high purity, are very resistant to wear and have high chemical resistance. However, they become fragile in the presence of sudden changes in temperature (thermal shock).

• Code X: Stéatite.

Its composition is silica oxide (SiO₂) 52%, magnesium oxide (MgO) 23%, alumina oxide (Al₂O₃) 5.1%. It is ochre in colour and used in clean water applications. An economical material. Has low chemical resistance and low thermal conductivity, for which reason it does not dissipate heat well. Low resistance to thermal shock.

• Code V: Alumina oxide with a purity of 99.5%.

It is chemically inert and has excellent resistance to wear. Due to its purity, it can withstand a higher degree of thermal shock than other types of ceramic. It is recommended in clean water operations, in combination with graphite (B).

Low thermal conductivity and poor heat dissipation. Low resistance to thermal shock.

Metal carbides

Metal carbides are extremely hard materials manufactured by sintering. They have high chemical and wear resistance and are used in environments with solids or particles which can attack soft materials such as carbon.

- **Code U: Inserted / welded tungsten carbide.**

An extremely hard and tenacious material. It is appropriate for applications with a pH of more than 6 (in the case of welded parts).

Good behaviour with respect to wear under severe conditions. Good thermal conductivity. High elastic modulus, meaning it is not likely to become deformed, especially in high pressure applications. Limited chemical resistance, especially to acid products. A very high density material, which can be critical in high speed rotating operations.

Limited capacity to withstand dry operation conditions or extremely limited lubrication conditions, especially when working with the same material.

- **Code Q: Silicon carbide.**

Good resistance to wear and to friction in heavy duty work. It is the perfect material for working in contact with abrasive and corrosive fluids, and at high pressures. Its main characteristics are as follows:

- High thermal conductivity, comparable to tungsten carbide.
- Low resistance to thermal shock.
- High elasticity modulus.
- Good chemical resistance.
- Lower density than tungsten carbide.

May be subject to chemical attack by certain strong alkaline products. For that reason it is important to choose the most appropriate silicon carbide grade:

Q₁: Contains no free silicon. It has the best chemical resistance of all carbides, but low tenacity. Its friction characteristics are poorer than grade Q₂, but higher than those of tungsten carbide.

Q₂: Contains free silicon. It has the best friction characteristics of all silicon carbides. Some acid or alkaline substances may cause lixivation in free silicon but in general, it is more inert than tungsten carbide.

Q₆: Has a silicon and graphite carbide base. This mixture combines the high resistance to wear of silicon carbide and the lubricant properties of graphite.

Silicon carbide normally runs against resin-impregnated graphite (B), but metal carbons may also be used for high performance (hot water applications). The silicon carbide and carbon combination is frequently used, providing long life in a wide range of conditions due to its excellent resistance to thermal shock.

- **Código U: Solid tungsten carbide with nickel.**

An extremely hard and tenacious material. Limited chemical resistance, especially to acid products. Suitable for applications with pH values above 2. Good behaviour with respect to wear under severe conditions. Good thermal conductivity. High elastic modulus, meaning it is not likely to become deformed in comparison with metal materials. A very high density material, which can be critical in high speed rotating operations.

Limited capacity to withstand dry operation conditions or extremely limited lubrication conditions, especially when working with the same material.

In applications with abrasives, it is advisable to use silicon carbide against tungsten carbide, which is the most effective combination due to its resistance to wear and friction.

Silicon carbide may work against itself in very abrasive conditions but the friction characteristics are not as good as silicon carbide against tungsten carbide.

When silicon carbide is used against itself, the best results are obtained using different types, for instance Q₁ against Q₂ or Q₂ against Q₆.

When hard material is worked against hard, the limited conditions of the application may give rise to sudden changes in surface temperature and dry operation. Although this occurs with a short space of time, it is best to use silicon carbide with graphite-impregnated silicon carbide (Q₆). Due to its graphite content, this combination is resistant to the absence of lubrication for a limited time.

Metals

- **Code E: AISI 420 chromium steel.**

This is tempered stainless steel with a surface hardness of less than 50 HRc. It is used with fluids such as water or oils.

- **Code F: Nickel-chromium steel AISI 304.**

Stainless steel used to manufacture springs and auxiliary parts.

- **Code F₁: Nickel-chromium steel.**

Stainless steel with good chemical resistance, used for fluids such as water, oils, chemicals, etc.

- **Code G: AISI 316 nickel-chromium-molybdenum steel.**

Stainless steel with very good chemical resistance used with water, oils, hydrocarbons and chemicals.

- **Code G₂: AM350 nickel-chromium-molybdenum steel.**

Specifically for metal bellows that must work at high temperatures up to +300°C.

- **Code L: Nickel-chromium-molybdenum steel; AISI 316L.**

Stainless steel with excellent chemical resistance. It provides a homogeneous surface with no pores and is recommended for hygienic applications.

- **Code Z: Nickel-chromium-molybdenum steel with chrome oxide.**

It is a coating of Chromium Oxide deposited on the steel by means of plasma. The hardness is superior to that of stellite steel.

- **Code Z₂: Nickel-chromium-molybdenum stellite steel.**

To obtain it, the steel surface is treated with plasma, leaving a thickness of 0.2 to 0.3 mm. with considerable surface hardness and increased resistance to wear.

- **Code D:**

Nickel-molybdenum duplex stainless steel, used for highly corrosive environments: marine, industrial, etc.

- **Code M: Hastelloy® C4**

A nickel, chromium and molybdenum alloy with great mechanical resistance and excellent chemical resistance for general use. It is used to make springs or auxiliary parts.

- **Code M₂: Inconel®718 (2.4668)**

A nickel (53%), chromium (18%), tantalum-niobium (5%) and molybdenum (3%) alloy. Good resistance to corrosion and excellent resistance to extreme temperatures, both high (600°C) and low (-250°C).

- **Code M₁: Monel®400.**

A nickel (63%) and copper (23%) alloy. High resistance to corrosion in saline, caustic and acid environments (hydrochloric acid, hydrofluoric acid, sulphuric acid) and at high and low temperatures. Good mechanical properties. Due to its copper content, it has low resistance to nitric acid and ammonia. Very often used in the naval sector.

Synthetic or plastic materials

These materials are widely recommended for cases in which carbon lacks the adequate chemical resistance. They are manufactured with a PTFE base mixed with different additives and have very high chemical resistance. They withstand temperatures of up to +240°C. Their use is limited to low pressures and speeds (PV factor).

- **Code Y:** Glass-filled

- **Code Y₁:** Graphite-filled PTFE

Secondary seals

- **Code P: Nitrile butadiene rubber NBR.**

For working with water, oil, grease, etc. Temperature resistance from -30°C to +100°C.

- **Code H: Hydrogenated NBR.**

Excellent resistance to lubricants and products refrigerants at temperatures of up to +150°C.

- **Code N: Chlorobutadiene rubber Neoprene® or CR.**

For fluids such as refrigerants, ozone, glycols, etc. Temperature resistance of from -40°C to +100°C.

- **Code E: Ethylene-propylene diene monomer EPDM.**

Good behaviour in the presence of hot water, steam, acetone, alcohol, etc. Temperature resistance from -40°C to +120°C.

- **Code X: Ethylene-propylene rubberhardened with peroxide (EPDMPX).** Good behaviour in the presence of hot water, steam, acetone, alcohol, etc. In contact with steam up to +130°C in continuous operation and peaks of +150°C.

- **Code S: Methyl-vinyl silicon rubber MVQ.**

Indicated for applications at low temperatures from -60°C to +200°C.

- **Code V: Fluorocarbon (FKM)**

High chemical and temperature resistance. Withstands temperatures of -15°C to +200°C except in hot water applications, in which case the temperature should not exceed 120°C.

- **Code K: Perfluorelastomer rubber FFKM.**

Excellent chemical resistance to a wide range of working fluids. Withstands temperatures ranging from -30 to +250 or +320°C depending on the type.

- **Code M: FEP encapsulated seals.**

Their chemical resistance is similar to that of PTFE. They are suitable for working at high temperatures ranging from -15°C to +200°C. Their main problem is the plastic behaviour of their surface, which makes them difficult to assemble in closed housings and they have a greater risk of being damaged.

- **Code A: Tetrafluoroethylene rubber, Aflas® or TPE/P.**

A material with high chemical resistance to most products and suitable for working with steam at temperatures up to +170°C and lubricants at temperatures up to +200°C.

- **Code G:**

Non-elastomer material with a graphite base used for high temperature applications. Withstands temperatures up to +400°C

- **Code T: Polytetrafluoroethylene PTFE.**

High chemical resistance to practically all substances. Withstands temperatures ranging from -200°C to +260°C.

Chemical resistance chart

The information in the following table refers to the chemical compatibility of mechanical seals with fluids, and should be considered as a general guideline for an initial orientation in the selection of a mechanical seal. For technical or economic reasons, other types of mechanical seals with different materials than those indicated here may be proposed.

Fluid	Materials					
	I Rotary face	II Stationary face	III Elastomers	IV Springs	V Other metal parts	• Notes
Acetaldehyde	B	V	T	G	G	D
Acetic acid < 30 %	B	V	E	G	G	
Acetic acid ester (Propyl acetate)	B	V	T	G	G	
Acetic acid, glacial	B	V	T	G	G	
Acetic anhydride	B	V	T	G	G	
Acetone	F1	B	E	G	F1	
Acetyl chloride	V	B	V	G	G	
Acetyl salicylic acid	B	V	E	G	G	
Acetylene	V	B	E	G	G	D
Acrylonitrile	Q	Q	T	G	G	D
Adipic acid	G	B	V	G	G	
Alum (ammonia)	Q	Q	P	G	G	
Alum (chrome)	X	B	P	G	G	
Alum (potash)	Q	Q	P	G	G	
Aluminium	V	B	E	G	G	
Aluminium acetate	Q	Q	E	G	F	
Aluminium chloride	V	B	V	G	G	
Aluminium nitrate	V	B	P	G	G	
Aluminium sulphate	Q	Q	V	G	G	
Ammonia and oil	V	B	N	G	G	
Ammonia gas	X	B	E	G	G	D
Ammonia liquid	X	B	E	G	F	
Ammonium acetate < 10%	V	B	E	G	G	
Ammonium bromide < 10%	X	B	P	G	G	
Ammonium carbonate	V	B	E	G	G	D
Ammonium chloride	V	B	E	G	G	D
Ammonium hydrogen carbonate < 10%	V	B	E	G	G	
Ammonium hydroxyde	F1	B	E	G	F1	D
Ammonium nitrate	Q	B	P	G	G	
Ammonium pebulfate < 20 %	V	B	P	G	G	
Ammonium phosphate < 15%	V	B	P	G	G	
Ammonium sulfide	V	B	P	G	G	
Ammonium sulphate < 10 %	Q	Q	P	G	G	
Amyl acetate	V	B	E	G	G	
Amyl alcohol	F1	B	E	G	F1	
Amyl benzoate	F1	B	E	G	F1	
Amyl butyrate	F1	B	E	G	F1	
Amyl formate	F1	B	E	G	F1	
Amyl nitrate	F1	B	E	G	F1	
Amyl propionate	F1	B	E	G	F1	
Aniline	G	B	T	G	G	
Anthracene	Q	Q	V	G	G	
Arachic oil (peanut oil)	V	B	P	G	G	
Arsenic acid	V	B	V	G	G	D
Ascorbic acid	V	B	E	G	G	
Barium chloride	V	B	E	M2	M2	D
Barium hydroxide	V	B	P	G	G	
Barium nitrate	Q	Q	P	G	G	
Barium sulfide	V	B	P	G	G	
Barium sulphate	V	B	E	G	G	
Beer	X	B	V	G	F	
Benzene (benzol)	F1	B	V	G	F1	
Benzoic acid	V	B	V	G	G	
Borax (solution)	Q	Q	E	G	G	
Boric acid	Q	Q	P	G	G	
Brine	Q	B2	V	G	G	
Bromemethane	F1	B	V	G	F1	D
Butadiene	V	B	E	G	G	D
Butane	F1	B	V	G	F1	
Buthyl alcohol	X	B	P	G	F	
Butter	X	B	P	G	F	
Butyl benzoate	F1	B	E	G	F1	
Butyl butyrate	F1	B	E	G	F1	

Fluid	Materials					
	I Rotary face	II Stationary face	III Elastomers	IV Springs	V Other metal parts	• Notes
Butyl cellosolve	Y	V	T	G	G	
Butyl formate	F1	B	E	G	F1	
Butyl lactate	F1	B	E	G	F1	
Butyl phosphate	F1	B	E	G	F1	
Butyl phthalate	F1	B	E	G	F1	
Butylamine	B	V	T	G	G	
Butylene	F1	B	V	G	F1	
Butyric acid	V	B	T	G	G	
Calcium acetate	V	B	E	G	G	
Calcium carbonate	Q	Q	P	G	G	
Calcium chloride	Q	B2	V	G	G	
Calcium hydrogen sulphate < 10%	X	B	P	G	F	
Calcium hydroxide > 10 %	Q	Q	P	G	G	*
Calcium hypochlorite 10 %	C1	V	E	G	G	
Calcium nitrate	X	B	P	G	G	
Calcium phosphate	B	V	P	G	G	
Calcium sulfide	V	B	P	G	G	
Camphor	Q	Q	T	G	G	
Carbinol	X	B	P	G	G	
Carbitol	G	B	T	G	G	
Carbolic acid	G	B	V	G	G	
Carbon dioxide	Q	B	P	G	G	
Carbon disulfide	G	B	T	G	G	D
Carbon monoxide	G	B	E	G	G	D
Carbon tetrachloride	V	B	V	G	G	
Carbonic acid	Q	B	E	G	G	
Carbonic anhydride	V	B	P	G	G	D
Castor oil	V	B	P	G	G	
Cellulose acetate	V	B	T	G	G	D
Cheese	Q	Q	V	G	F	D
Choline, dry	Y	V	V	G	G	*/D
Chlorine solvents	V	B	T	G	G	
Chlorine, wet	Y	V	V	M1	M1	*
Chlorobenzene	G	B	V	G	G	
Chloroethane	F1	B	V	G	F1	
Chloroform	Q	B	V	G	F	
Chloromethane	G	B	V	G	G	
Chloropentane	G	B	V	G	G	
Chromic acid	Q	Q	V	G	G	D
Citric acid	X	B	E	G	G	
Cocoonut oil	V	B	P	G	G	
Cod liver oil	V	B	P	G	G	
Coffee	X	B	P	G	F	
Copper chloride	Q	Q	V	G	G	*
Copper cyanide	V	B2	P	G	G	D
Copper sulphate	V	B	P	G	G	
Cresol	G	B	T	G	G	
Cresylic acid	G	B	V	G	G	
Cumene	G	B	V	G	G	
Decahydronaphthalene F1	B	V	G	F1		
Diacetone alcohol	G	B	E	G	G	
Dichloroacetic acid	Y	B	T	M1	M1	
Dichlorobenzene	G	B	V	G	G	
Dichloroethane	G	B	T	G	G	
Dichloroethylene	G	B	V	G	G	
Dichloromethane	G	B	V	G	G	
Diethanolamine	G	B	T	G	G	
Diethyl carbonate	V	B	E	G	G	
Diethyl phthalate	G	B	T	G	G	
Diethylamine	G	B	T	G	G	
Diethylene glycol	F1	B	P	G	F1	
Dimethyl sulphoxide	G	V	B	G	G	
Dimethyl formamide	B	V	T	G	G	
Dimethyl phthalate	G	B	V	G	G	
Dinitrochlorobenzene	G	B	T	G	G	

CHEMICAL RESISTANCE CHART

Materials					
I	II	III	IV	V	•
Rotary face	Stationary face	Elastomers	Springs	Other metal parts	Notes

Fluid

Diocetyl phthalate	G	B	T	G	G
Dirty water	Q	Q	P	G	F
Distilled water	X	B	P	G	F
Drinking water	X	B	P	G	F
Epichlorhydrin	V	B	T	M2	M2 D
Essences	G	B	E	G	G
Ethane	Q	B	V	G	F
Ethanodiol	X	B	P	G	F
Ethanol	X	B	P	G	F
Ethanolamine	G	B	T	G	G
Ethyl acetate	V	B	T	G	G
Ethyl alcohol (etanol)	X	B	P	G	F
Ethyl benzoate	G	B	V	G	G
Ethyl butyrate	G	B	E	G	G
Ethyl chloride	B	V	T	G	G
Ethyl formate	F1	B	E	G	F1
Ethyl phthalate	F1	B	E	G	F1
Ethyl propionate	F1	B	E	G	F1
Ethyl sulphate	F1	B	E	G	F1
Ethylene oxide (gas T)	V	B	T	G	G D
Ethylene	Q	B	V	G	F
Ethylene chloride	V	B	T	G	G
Ethylene glycol	X	B	E	G	F
Fat	Q	Q	P	G	F
Fatty acids	V	B	V	G	G
Ferric chloride	Y	V	P	G	G *
Ferric sulphate < 20 %	B	V	P	G	G
Ferrous sulphate < 20 %	B	V	P	G	G
Food products	Q	Q	P	G	G *
Formaldehyde	V	B	T	G	G D
Formic acid	B	V	E	M1	M1
Formic acid > 40° C	Q1	B2	K	G	G
Freon 11	Q	B2	T	G	F
Freon 112	F1	B	V	G	F1
Freon 113	X	B	N	G	F
Freon 114	X	B	N	G	F
Freon 115	X	B	N	G	F
Freon 12	X	B	N	G	F
Freon 13	X	B	N	G	F
Freon 14	X	B	N	G	F
Freon 21	Q	B2	T	G	F
Freon 22	F1	B	N	G	F1
Freon 31	F1	B	N	G	F1
Freon 32	F1	B	N	G	F1
Freon TF	X	B	P	G	F
Fruit (juice)	V	B	P	G	G
Fumaric acid	V	B	P	G	G
Furfural	Q	Q	T	G	G
Furfuryl alcohol	Q	Q	T	G	G
Gallic acid	V	B2	V	G	G
Gas oil	X	B	V	G	F
Gas town	V	B	V	G	G D
Gelatine	Q	Q	P	G	F
Glucose	F1	B	V	G	F1
Glycerine	Q	B2	P	G	F
Glycol ethylene	X	B	E	G	F
Grain oil	V	B	P	G	G
Grape juice	Q	Q	P	G	F
Heavy water	G	B	P	G	G
Helium	V	B	E	G	G D
Heptane	G	B	V	G	G
Hexane	G	B	V	G	G
Hexanone	G	B	T	G	G
Hdraulic oil	F1	A	P	G	F1
Hydrazine	V	B	E	G	G *
Hydrochloric acid	V	B2	V	G	G *
Hydrocyanic	V	B2	V	G	G
Hydrocyanic acid	V	B	E	G	G
Hydrofluoric acid 40 %	T	Y	T	G	T */D
Hydrogen	F1	B	P	G	F1 D
Hydrogen peroxide	Y	V	V	G	G D
Hydrogen sulphide	Y	V	V	G	G
Ice-cream	V	B2	P	G	G
Ink	V	B	V	G	G
Iodine	Y	V	V	G	G
Isoamyl alcohol	V	B	E	G	G
Kerosene	F1	B	V	G	F1
Lactic acid	G	B	V	G	G

Materials					
I	II	III	IV	V	•
Rotary face	Stationary face	Elastomers	Springs	Other metal parts	Notes

Fluid

Lard	Q	Q	P	G	F
Lead nitrate	V	B2	P	G	G
Linseed oil	V	B	P	G	G
Liquers	G	B	V	G	G
Lubricants	F1	A	P	G	F1
Lubricating oil	F1	A	E	G	F1
Lysoform	G	B	T	G	G
Magnesium chloride > 5%	V	B	E	M1	M1
Magnesium hydroxide < 10 %	V	B	E	G	G
Magnesium sulphate	V	B	E	G	G
Maleic acid	V	B	V	G	G
Maleic anhydride	Q	B	T	G	G
Malic acid	V	M	P	G	G
Malonic acid	G	B	P	G	G
Manganese chloride	G	B	V	G	G
Manganese nitrate	V	B	E	G	G
Manganese sulphate	G	B	V	G	G
Mayonnaise	Q	Q	P	G	F
Mercaptane (ethyl mercaptane)	V	B	T	G	G D
Mercury chloride	V	B	E	G	G D
Mercury nitrate	V	B	V	G	G
Methane	Q	B2	T	G	F D
Methanol	G	B	E	G	G
Methyl acetate	G	B	T	G	G
Methyl acrylate	G	B	T	G	G
Methyl alcohol (methanol)	X	B	P	G	F
Methyl benzoate	G	B	V	G	G
Methyl bromide	V	B	V	G	G
Methyl butyrate	G	B	T	G	G
Methyl formate	G	B	T	G	G
Methyl methacrylate	G	B	T	G	G
Methyl propionate	G	B	T	G	G
Methylamina	G	B	T	G	G
Methyl-butyl ketone	V	B	E	G	G
Methylchloride	G	B	V	G	G D
Methylene chloride	G	B	T	G	G
Methylene oxide	G	B	T	G	G
Methyl-ethyl ketone	G	B	E	G	G
Methyl-isobutyl ketone	G	B	E	G	G
Milk 100 ° C	V	B	E	G	G
Mineral oil	F1	A	P	G	F1
Molasses	Q	Q	P	G	F
Naphtalene	Q	Q	V	G	F
Naphtha	F1	A	V	G	F1
Nickel chloride	V	B	P	G	G
Nickel sulphate	V	B	P	G	G
Nitric acid < 20 %	V	B2	V	G	G
Nitric acid > 20 %	Q	Q	T	G	G
Nitro benzene	G	B	T	G	G
Nitro solvents	V	B	T	G	G
Nitrocellulose	Q	Q	T	G	F
Nitrogen	V	B	P	G	G D
Nitroglycerine	F1	B	V	G	F1
Nonil phenol	G	B	V	G	G
Octyl alcohol	F1	B	E	G	F1
Oil (cutting soluble)	F1	A	P	G	F1
Oil (domestic fuel)	Q	Q	P	G	F
Oil (paraffin base)	V	B2	V	G	G
Oil (transformer)	F1	A	P	G	F1
Oil and ammonium	F1	B	N	G	F1
Oleic acid	V	B	T	G	G
Olive oil	V	B	P	G	G
Oven gas	G	B2	V	G	G D
Oxalic acid	V	B	E	G	G
Oxygen (gas)	Y	V	V	G	G */D
Ozone	Y	V	E	G	G D
P.V.A. (polyvinyl acetate)	Q	Q	E	G	G
P.V.C. (polyvinyl chloride)	Q	Q	E	G	G
Palmitic acid	V	B	V	G	G
Paraffins	F1	B	V	G	F1
Pentane	F1	B	V	G	F1
Perchloro etylene	V	B	V	G	G
Petrol < 97 octanes	V	B	P	G	G
Petrol > 97 octanes	V	B	V	G	G
Petroleum	Q	Q	V	G	G

CHEMICAL RESISTANCE CHART

Materials					
I	II	III	IV	V	•
Rotary face	Stationary face	Elastomers	Springs	Other metal parts	Notes

Fluide

Petroleum (kerosene)	F1	B	V	G	F1
Petroleum ether	F1	B	V	G	F1
Petroleum oil	F1	A	P	G	F1
Phenol	G	B	V	G	G
Phenolctyl	G	B	T	G	G
Pheny chloride	G	B	V	G	G
Phosphoric acid < 10 %	V	B2	E	G	G
Phosphoric acid concentrated	V	Y	V	M1	M1
Phthalic acid	V	B	T	G	G D
Phthalic anhydride	Q	Q	T	G	G
Picric acid	V	B	V	G	G
Potassium acetate	V	B	E	G	G
Potassium bromide	Q	Q	T	G	G
Potassium carbonate	V	B	P	G	G
Potassium chlorate	V	B	T	G	G
Potassium chloride	V	B	P	M2	M2
Potassium cyanide	V	B	P	G	G D
Potassium hydrogen carbonate	V	B	P	G	G
Potassium phosphate	V	B	V	G	G
Potassium silicate	V	B	P	G	G
Potassium sulphate	V	B	P	G	G
Propane	F1	B2	P	G	F1
Propellant	G	B	T	G	G
Propil acetate	Y	V	T	G	G
Propionate butyl	F1	B	E	G	F1
Propionic acid	B	V	T	G	G
Propyl benzoate	F1	B	E	G	F1
Propyl butyrate	F1	B	E	G	F1
Propyl formate	F1	B	E	G	F1
Propyl phthalate	F1	B	E	G	F1
Propyl propionate	F1	B	E	G	F1
Propylene	Q	B	V	G	G D
Propylene glycol	F1	B	V	G	F1
Propylene oxide	V	B	T	G	G D
Pyridine	G	B	T	G	G
Pyrogallic acid	V	B	V	G	G
Rapeseed oil	G	B	V	G	G
Resin (alkyd)	Q	Q	V	G	G D
Resin (melamine)	Q	Q	T	G	G D
Resin (phenolic)	Q	Q	V	G	G D
Salicylic acid	V	B	E	G	G
Sandy water (high concentration)	Q	Q	P	G	F
Sea (salt) water	V	B	P	G	G
Silicone liquid	Q	B	E	G	F
Silicone oil	F1	A	E	G	F1
Soap solution	X	B	P	G	F
Sodium acetate >10%	V	B	E	G	G D
Sodium carbonate	V	B	P	G	G
Sodium chloride < 10%	V	B	E	G	G D
Sodium citrate	Q	Q	E	G	G
Sodium cyanide	V	B	P	G	G D
Sodium dichromate	Y	B	T	G	G
Sodium disulfite	V	B	P	G	G
Sodium hydrogen carbonate	V	B	P	G	G
Sodium hydrogen sulphate < 20%	V	B	P	G	G
Sodium hydroxide < 10 %	Q	Q	E	G	F
Sodium hydroxide > 10 %	Q	Q	E	G	F D
Sodium hypochlorite	Y	V	V	M1	M1 *
Sodium nitrate	V	B	E	G	G
Sodium silicate	Q	Q	P	G	G
Sodium sulfide	V	B	P	G	G
Sodium sulfide < 2 %	V	B	P	G	G
Sodium sulphate	Q	Q	P	G	G
Sodium tetraborate	Q	Q	E	G	G
Sodium thiocyanate	V	B	P	G	G D
Sodium thiosulfate	V	B	E	G	G
Soyabean oil	V	B	P	G	G
Starch	Q	Q	E	G	F *
Stearic acid	V	B	T	G	G
Stoddard solvent	G	B	V	G	G
Styrene	Q	Q	T	G	G
Succinic acid	V	B	E	G	G
Sugar juice	V	B	P	G	G

Materials					
I	II	III	IV	V	•
Rotary face	Stationary face	Elastomers	Springs	Other metal parts	Notes

Fluide

Sugar juice < 10 %	Q	Q	P	G	G
Sugar juice > 10 %	Q	Q	P	G	G */D
Sulphonated oils	V	B2	V	G	G
Sulphuric acid < 10 %	V	B2	V	G	G
Sulphuric acid < 35 %	Y	V	V	M	M
Sulphuric acid concentrated	Y	V	V	M	M *
Tannic acid	V	B	P	G	G
Tannin	V	B	P	G	G
Tartaric acid	V	B	P	G	G
Tetrachloro ethane	V	B	V	G	G
Tetrachloro ethylene	V	B	V	G	G
Tetrahydrofuron	V	B	T	G	G
Thermic oil	F1	A	V	G	F1
Toluene	V	B	V	G	G
Tomatoe juice	Q	Q	P	G	G
Tooth paste	Q	Q	P	G	F *
Trichloro acetic acid < 50 %	V	B2	T	G	G
Trichloro ethane	G	B	T	G	G
Trichloro ethylene	V	B	V	G	G
Tricresyl phosphate	V	B	E	G	G
Triethanolamine	G	B	T	G	G
Triethylamine	V	B	P	G	G
Turpentine	X	B	P	G	F1
Turpentine	X	B	P	G	F
Urea	V	B	T	G	G D
Urea formaldehyde resins	Q	Q	T	G	G D
Varnish	Q	Q	V	G	G D
Varnish (solvent nitro)	Q	Q	T	G	G D
Vegetable oil	F1	A	P	G	F1
Vinegar	F1	B	E	G	F1
Vinyl acetate	G	B	T	G	G
Vinyl chloride	Q	Q	T	G	G D
Viscose	Q	Q	T	G	G D
Water	X	B	P	G	F
Water (de-ionised)	G	B	P	G	G
Water (demineralised)	X	B	P	G	F
Water (detergent)	X	B	P	G	F
Water (mud)	Q	Q	P	G	F
Water (sandy)	Q	Q	P	G	F
Water (soapy)	X	B	P	G	F
Water < 140 °C	Q	B2	E	G	F
Water < 90 °C	V	B	P	G	F
Water and oil (emulsion)	F1	A	P	G	F1
Wax	F1	B	V	G	F1
Whisky	X	B	P	G	F
Wine	X	B	P	G	F
Xylene (xylol)	V	B	V	G	G
Zinc chloride	V	B	P	G	G
Zinc cyanide	V	B	P	G	G D
Zinc nitrate	V	B	P	G	G
Zinc sulphate 2 %	V	B	P	G	G D

D: Back to back double seal assembly (with barrier fluid compatible with the product at a pressure of 1,5 to 2 Bar above the pressure of the pressure to be sealed).

*: Consult a technical office.

Compatibility chart

LIDERING	CRANE	BURGMANN	AES	VULCAN	ROTEN	OTHERS
MULTISPRING SEALS						
LMS11	-	M74	-	-	-	-
LMS20/ LMS20T	109 / 909 / 8 / 8T / 58U / 9 / 9	-	M01/ M03	1609	90	Flowserve 8, Usseal VGMD, Usseal X Usseal W
LMS20B / LMS20BT	9B / 8-1 / 8B / 58B / 59B / 109B	-	M04	1609B / 1609BS	-	-
LMS13	-	-	-	-	-	FLUITEN UM3A
LMS14	-	HJ4	-	-	-	DEPAC 186, Flowserve BPO, Chesterton 891
LMS15D	-	-	-	-	877	Chesterton 440
LMS22	-	-	-	-	-	Flowserve Dura R0
LMS28	32	-	-	-	-	-
LMS29	-	HRN	-	-	-	DEPAC 196, CHETRA 208, 210
LMS10D	-	M74D	-	-	822	-
WAVE SPRING SEALS						
LWS10	-	M7N / M78N	W07 DM	1677	-	Flowserve Europac 600, Latty U68
LWS10B	-	H7N	-	1678	-	Latty B68
LWS12	R33	-	-	1633	-	-
LWS30 / LWS30A	-	HJ92 / HJ977GN	M02 / H010	1609B / 40L	EHS	Chesterton 40S, 880, Latty B23
LWS70 / LWS71	80-87 / 80(DF / FP)	-	W01 / W02	1688 / 1688L	7 / UN 7	Flowserve 168
AXIAL SPRING SEALS						
LS18/ LS19	-	M3N	T01	8 / 8 DIN	L4B	Flowserve CRO, 38, Latty U1000, Usseal VGME-2, Usseal VGME-3
LS60IN	-	-	-	-	2E	-
RN / LS60	-	-	T03	12	2	Flowserve 42
RN.NU / LS60DIN	-	-	T03 DIN	12 DIN	UN 2	Flowserve 42D
LS18B	-	H12N	T02	8B	-	Flowserve CRO / 39 Usseal VGME-1
RNB / LS60B y RN.NB / LS60BDIN	-	-	-	-	E / UN E	-
FN / LS15	-	-	T04	13	3	Flowserve 43, Usseal VGMB
FN NU / LS15DIN	-	-	T04 DIN	13 DIN	UN 3	Flowserve 43D, Usseal VGMC-13
FH/FHC	-	-	-	7	5/5H2	-
LS40A	RD / 8TD / 8RTD / 1507	-	P080	98	U2	Flowserve ARO, FRO
LS40C	RD / 8TD / 8RTD / 1507	-	-	97	U2	Flowserve ARO, FRO
BELLOWS SEALS						
AR / LRB31	PR / DR	-	B01	18	37B / L5	Flowserve 118, Usseal VGMA
LRB00	2	-	P02 / P04U	A2 / A4	-	Flowserve 52, 31, Usseal D
LRB00L	1A (N SEAT)	MG910 / D1-G50	P01 / P01T	A1 / 10	51	Flowserve 100, Usseal U
LRB00U + PF L50	1 (US)	MG901 / D1-G55	P05 U	A5 / 22	-	Flowserve 51, Usseal E
LRB01	21 / 43 CU short	MG921 / D1-G55	P04 / P04T	11	21A	Usseal C
LRB01S	-	MG920 / D1-G50	P02,P02T	20	-	Flowserve 200
LRB04 / LRB06	521	MG912 / D1-G60	P03	24	52 / L4K	Flowserve 240, Usseal VGMG
PNL	-	-	-	-	-	-
LRB02	6	-	B-04 / B-04 U	65	16	Flowserve PAC SEAL 16, Usseal A/AV
LRB03/LRB03A / LRB03B	6A / 7	A2	B-03 / B03 U	75	68	Flowserve 68, 170, Usseal B/BV
LRB17	-	MG1	B02	A19	L3	Flowserve 190, Usseal VGMC-1
LRB17A	-	-	-	-	NTA	-
LRB17E	-	MG1S20	BP02	1520	-	Flowserve 150
LRB17KU	-	MG12	B012	A192	L3K	Flowserve 192, Usseal VGMC-12
LRB17NU	-	MG13	B013	A193	L3N	Flowserve 193
LRB25	2100 S	-	B05	14 DIN	-	Flowserve 140, Usseal G
LRB25KU	2100 KU	-	B052	142DIN	-	Flowserve 142, Usseal G
LRB25NU	2100 NU	-	B053	153DIN	-	Flowserve 143, Usseal G
LRB50	502(NSEAT)	-	B07	1724	-	Usseal I
LMB84	-	MBS100 / MFL	BSAI / BSAIG	-	-	Chesterton 286, Latty B17SH
LMB85	680	M FL85N	-	-	-	Chesterton 886, Latty B17
LMB86	609	-	-	-	-	-
LTB16	20 / 10T	-	-	-	-	Flowserve TBR
ACCESSORIES						
LST 6	-	TS1000	-	-	-	-
LST 10	-	TS2000	-	-	-	-
LQT	-	QTF	-	-	-	-

Packing



Packing is used to seal rotating, alternating or helical movements. Its operating or sealing principle is achieved through the interference obtained by external tightening.

Our packing is supplied in rolls of different lengths. The weight of these rolls depends on the cross-section, length and material. This catalogue contains a selection of the main materials we supply, depending on the working conditions and application points.

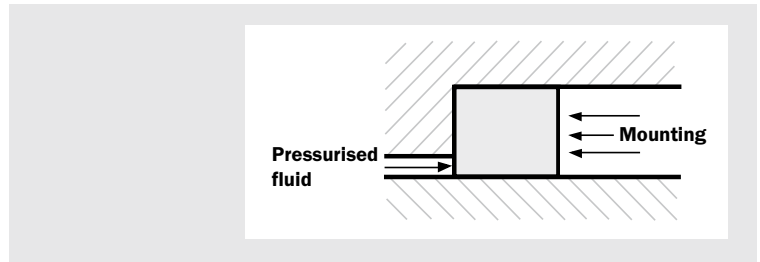

• **Mounting:**

When using packing in applications in which its use is necessary, it must be cut by hand and the ring must be shaped.

A cutting template can be used or the packing can be wound around the shaft and the rings cut. The 45° bevel cut is the most appropriate.

The rings must be inserted into the gasket one by one, with the cuts made at right angles to each other, tightened by the gasketed flange by hand. It is left to operate with constant leaks for 10 minutes and then tightened to reduce the leaks to an acceptable level (10 to 20 drops per minute).

Leakage in the form of dripping is essential and ensures that the rings will not overheat. The correct tightening for pump packings is 0.5 – 1.5 N/cm². For valves, the minimum tightening required is 5 N/cm².

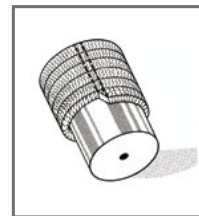

Operations A

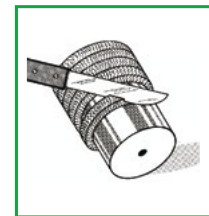

Operations B

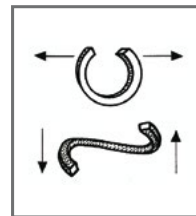

Operations C

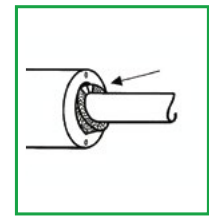

Operations D

• **Selection:**

To determine the correct braided packing type, the following must be known: fluid (liquid or gas), pH, temperature, pressure, type of movement, speed, shaft Ø and housing.

It is important to consider all these details when selecting the most suitable packing type.

• **Surface finishes, housings:**

To ensure the correct functioning of the packing it must be used in housings with certain finishes, otherwise it will rapidly deteriorate.

Centrifugal pump shafts Spindles Sleeves	[Rt = 1 à 2,5 microns
Gaskets	[Rt = 16 microns Ø ext.)

The shaft hardness should be at least 50 Rockwell C.

• **Packing types:**

- PTFE packing
- Graphite packing
- Fibreglass packing
- Packing with aramid fibres

Face seals

These seals are used for sealing in rotating applications in extremely harsh working conditions in which high resistance to wear is required.

They are formed by two identical metal rings situated opposite each other through a lapped area in two separate housings. One of the parts remains static in the housing while the other rotates with its housing.

The rings are designed in such a way that they open outwards with respect to the seal faces towards the shaft, forming a line (vacuum) in the shape of a cone that has the following benefits:

- The lubricant easily reaches the seal faces, due to the capillarity effect and the centrifugal force.
- As the wear increases, the face moves forwards toward the central shaft. Consequently the seal has considerable wear resistance. The seal is completely worn when the internal diameter is reached.

This type of seal is used in many different applications: caterpillar-tracked vehicles such as diggers and bulldozers, heavy trucks, farming machines, tunnel boring machines, mixers, agitators, wind farms, lobe pumps for highly viscous fluids, helical screw pumps, etc.



Identification guide mechanical seals

Company: Work fluids:

Contact person: Solid particles in suspension: YES NO

Pump brand: Model:

Working Conditions:

Temperature: Cleaning: YES NO

Pressure: Conditions:

Speed:

Rotary Part / Face:

Spring:

Single spring

Multi-spring

Wave spring

Others

Specify

Direction of rotation:

Right

Left

Independent

Example:

Set screw Spring Seals Conical

Spring Seals Cylindrical Bellows

Stationary Part:

Example:

With oring Rubber joint Anti-rotation slot Others

Dimensions (Sketch):

- Shaft diameter (d1): _____
- Exterior diameter of the rotary part (d3): _____
- Length of the rotary part, relaxed (without movement): _____
- Length of the rotary part, totally pressed: _____
- Length of the rotary part in working position (l3): _____
- Exterior diameter of the stationary part, oring includes (d7): _____
- High of the stationary part, from the rotating seal face till the end of the oring (l4): _____

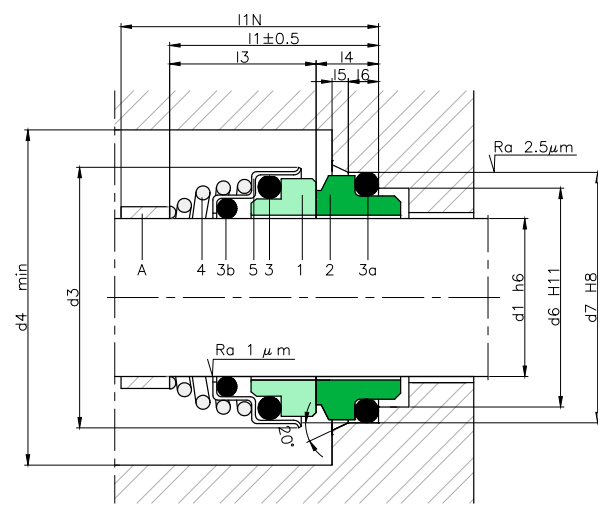

Cartridges identification guide

Working Conditions:



Speed (rpm):

Temperature (°C):

Pressure (bar):

Media:

Solid particles in suspension YES NO

New application: YES NO

Current Product:

Explanation of application:

Dimensions:

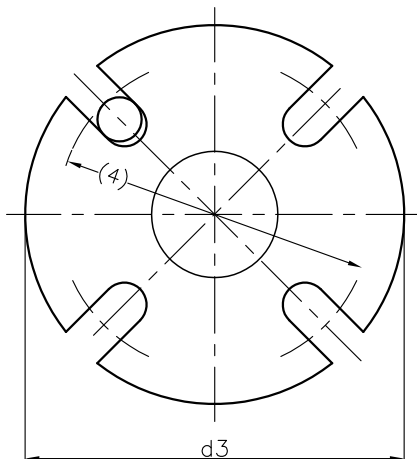
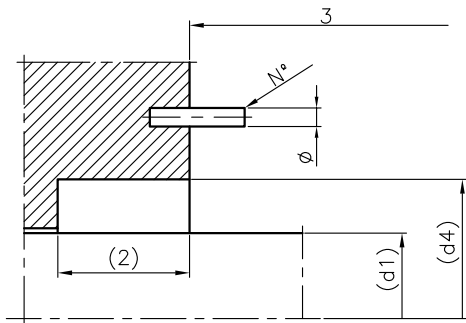

(d₁) Shaft diameter:

(d₂) Stuffing box diameter:

(1) Number of bolts and diameter:

N°

Ø

(2) Stuffing box length:

(3) Maximum installation length:

(d₃) Maximum diameter of gland:

(4) External diameter between bolts:

Naming codes

Multispring Seals Simple:

L **MS** Model - Shaft

Multispring Seals Double:

L **MS** Model - Shaft - **D**

Wave Springs Seals Simple:

L **WS** Model - Shaft

Wave Springs Seals Double:

L **WS** Model - Shaft - **D**

Spring Seals Simple:

L **S** Model - Shaft

Rubber Bellows Seals:

L **RB** Model - Shaft

PTFE Bellow Seals:

L **TB** Model - Shaft

Metal Bellow Seals:

L **MB** Model - Shaft



Lidering S.A.U.

España
Cornellà de Llobregat
(Barcelona)
Headquarters
International Sales
+34 93 480 44 22
Domestic Sales
+34 93 480 44 11
Reus (Tarragona)
Production
+34 977 327 016



Lidering S.A.R.L.

France
Tél. 04 72 67 02 67

Lidering GmbH

Deutschland
Tel. 0211 522 890 94

S.A. Lidering N.V.

Belgique-België
Tél. +34 93 480 44 22

Lidering Mechanical Seals, S.A.

Panamá
Tel. 397-1572

www.lidering.com

email: info@lidering.com



We support the Sustainable Development Goals



D - I - SM - 07/2021



Manufacturing Sustainable Solutions